

ashdown
ingram

Radiator Catalogue



Quality Starts Here...

The OEX Auto Electrical and Thermal Control Components range integrates the latest technologies, innovations and quality control checks to ensure delivery of market leading products.

Every time.



OEX[®]

Alternators | Starter Motors | Air Conditioning Components
Radiators | Lighting | Automotive Electrical Accessories

See the complete range of OEX products at www.quantumpro.com.au

THE SPECIALIST'S CHOICE



CONTENTS



Alfa Romeo	157
Audi	157
BMW	165
Chrysler	177
Citroen	178
Daewoo	179
Daihatsu	182
Eunos	187
Ford	188
Freightliner	208
Holden	209
Honda	236
Hyundai	244
Isuzu	253
Iveco	254
Jaguar	256
Jeep	257
John Deere	259
Kia	259
Land Rover	264
Lexus	265
Mack	267

MAN	268
Mazda	269
Mercedes-Benz	286
Mini	297
Mitsubishi	298
Nissan	312
Peugeot	327
Porsche	328
Proton	330
Renault	333
Rover	334
Saab	334
Scania	335
Seat	335
Skoda	336
Smart	336
Ssangyong	337
Subaru	337
Suzuki	345
Toyota	353
Volkswagen	388
Volvo	394

vehicle listing

general

Charge Air Cooler	398
Cross Reference Guide	445
Fast Find	454
Industrial Radiator Cores	413
Radiator Buyers Guide	157
Technical Pages	4
Vehicle Application Guide	14



Text and images courtesy of Denso International

6 Common Radiator Failures

This section has been compiled by investigating radiator failures in the past twenty years at Denso. These failures occur to all makes of radiators, due to incorrect maintenance and/or poor installation techniques.

We discuss the causes, results and prevention/repair method for each type of failure.

1. Contamination

Foreign Matter Inside the Radiator

Cause

- ▶ Insufficient flushing of the engine cooling system prior to fitting the new radiator.
- ▶ This includes the engine block, heater system and overflow bottle.
- ▶ Inadequate levels of fluid in the system for prolonged periods.
- ▶ Inadequate preparation prior to fitting the radiator, causing contamination of the engine cooling system.

Result

- ▶ Blockages of the radiator's tubes, header plate and tank.
- ▶ Reduction in cooling performance and efficiency.
- ▶ Engine overheating.
- ▶ Deterioration and failure of critical radiator components causing loss of coolant.

Prevention

- ▶ Regular service of the cooling system.
- ▶ Use the manufacturer's recommended coolant.
- ▶ Adequate flushing of the cooling system during coolant change.

A radiator leak caused by contaminated coolant.



Large deposit of foreign matter inside the radiator tank.



The headerplate and inside tube are covered with brown residue.



Text and images courtesy of Denso International

6 Common Radiator Failures

2. Corrosion

Mechanical and chemical deterioration of the radiator's tubes and header plates leading to holes and cracks in the core.

Cause

- ▶ Insufficient flushing of the engine cooling system prior to fitting the new radiator.
- ▶ This includes the engine block, heater system and overflow bottle.
- ▶ Mixing of different coolants.
- ▶ Contamination of the coolant via an additive.

Result

- ▶ Severely reduced corrosion protection.
- ▶ Tubes become weak and brittle eventually develop holes and cracks.
- ▶ Reduction in cooling performance and efficiency leading to conditions such as overheating.
- ▶ Loss of coolant.

Prevention

- ▶ Regular service of the cooling system.
- ▶ Use the manufacturer's recommended coolant.
- ▶ Adequate flushing of the cooling system during coolant change.
- ▶ Never mix different brands or types of coolant.

Evidence of corrosion on the radiator tube.



Lower tank covered in white residue.



The tubes on the header plate have become brittle and broken away.



Text and images courtesy of Denso International

6 Common Radiator Failures

3. Pitting Corrosion

Oil cooler failure is often caused by pitting corrosion, which is mainly due the following factors.

Cause

- ▶ Insufficient flushing of the engine cooling system prior to fitting the new radiator.
- ▶ This includes the engine block, heater system and overflow bottle.
- ▶ Mixing of different coolants.
- ▶ Incorrect concentration of coolant either at the time of change over or caused by dilution over a period of time
- ▶ Inadequate preparation prior to fitting the radiator, causing contamination of the engine cooling system.

Result

- ▶ The mixing of coolant/auto transmission fluid.
- ▶ Coolant enters automatic transmission.
- ▶ Damaging other cooling system components i.e. hoses.

Prevention

- ▶ Regular service of the cooling system.
- ▶ Use the manufacturer's recommended coolant.
- ▶ Adequate flushing of the cooling system during coolant change.
- ▶ Never mix different brands or types of coolant.



Oil cooler inside the radiator outlet tank.



Corrosion occurred on the surface of the coolers.

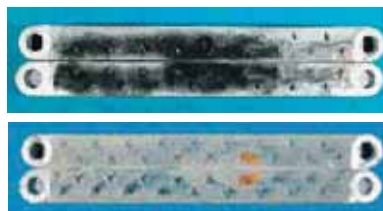

Oil cooler cut out section. Cross section magnified by 100k.



Text and images courtesy of Denso International

6 Common Radiator Failures

4. Electrolysis

Also commonly called “Stray Current” corrosion. This is a systematic removal of the protective layer on the inside of the radiator tubes due to improper grounding of one or more of the vehicle’s electrical components.

Cause

- ▶ Poor installation of aftermarket accessories.
- ▶ Existing stray current problem was not diagnosed and/or required prior to fitting a new radiator.

Result

- ▶ Systematic removal of the corrosion protection layer on the inside of the radiator’s tubes.
- ▶ Corrosion of the tubes typically resulting in multiple holes.
- ▶ Build-up of aluminium oxide blocking passages.
- ▶ White aluminium oxide powder visible through the inlet and outlet pipes.

Prevention

- ▶ Test for stray current in the cooling system.
- ▶ Repair poor electrical grounding.
- ▶ Check fitment of aftermarket accessories.

Dark pigmentation along the fins.



Blackening of the header plates. The tubes and brazed joints have corroded away.



Top header plate discoloured.



Evidence of the aluminium oxide residue settle inside the tank.



Text and images courtesy of Denso International

6 Common Radiator Failures

5. Thermal Shock

Thermal shock/stress is caused by drastic differences in temperatures.
Note: This only occurs in some models.

Cause

- ▶ Hot and high pressure coolant surging into the inlet side of the radiator can cause stress and fatigue to the radiator and in some cases cracking of the radiator tubes.

Result

- ▶ Tube fatigue failure.
- ▶ Leaking tube to core plate near inlet pipe.
- ▶ Leak will only start as slow seepage.

Prevention

Note: These repair methods are only effective for some models.

- ▶ Install thermostat with bleed hole, this will reduce thermal fluctuations by softening thermostat influence.
- ▶ Consult your repair shop for a replacement radiator.
- ▶ Always use original design radiator.
- ▶ Maintenance of coolant is also very important. Any corrosion to tube wall will accelerate tube fatigue.

Big temperature difference when hot coolant enters radiators causing tubes to flex.



Thermal shock affects tubes on the inlet side.

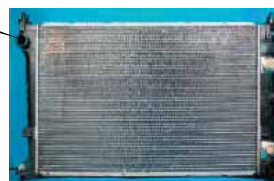

Coolant leakage, as a result of thermal shock.



Cut out tube section with crack. Cross section magnified by 35x

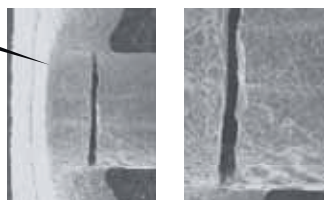

Text and images courtesy of Denso International

6 Common Radiator Failures

6. Radiator Cap

The radiator cap keeps the coolant level in the radiator at the desired amount. The cap releases coolant to the over flow bottle, at a certain pressure, then draws it back as the engine cools, to maintain the correct coolant level.

Cause

- ▶ Cracked or swollen gasket.
- ▶ Missing rubber seal.
- ▶ Weak Spring Tension.
- ▶ Melted by heat

Result

- ▶ Coolant leaking from the radiator.
- ▶ Pressure not maintained.
- ▶ Over pressure caused by fluid not being able to be passed to the flow bottle

Prevention

- ▶ When checking the coolant, also check the radiator cap for worn or cracked rubber gaskets. If the cap does not seal properly, fluid will be lost and the engine will overheat. A pressure test should be performed on your radiator cap to ensure it is working properly.

A weak radiator cap (or the wrong one for the application) can allow excessive amounts of coolant to escape into the overflow reservoir when the engine gets hot. Then prevents it from being siphoned back into the radiator as the engine cools leading to a low coolant level. So always pressure test the cap to make sure it holds pressure and meets the specifications for the application.



Cap gasket swollen by oil



Plastic portion of cap melted by overheated engine



Sample of a Well Maintained Radiator

Condition: At 135,000km regularly serviced and always using the recommended coolant.

Tubes

The radiator tubes were clear and the brazing appeared to be good



Plates

The header plate was as new. No visual sign of corrosion.

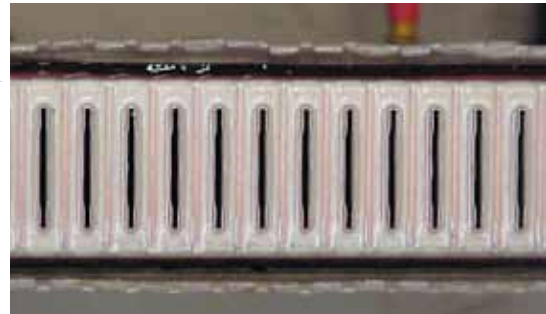

Tank

No signs of abnormal residue or foreign materials in the tank.



Oil Cooler

No visual sign of corrosion on the oil cooler.



How to Measure a Car Radiator Core

1. Ensure that the radiator is in an upright position. (The Filler-neck opening should be facing upward)
2. There are three specific measurements of the core required to determine the size of the radiator; height, width and thickness.
3. Determine whether the radiator is a Downflow or Crossflow type

Downflow versus Crossflow Type Radiators

There are two basic types of radiator design which are distinguished from one another by the location of the two end tanks and the direction of the coolant flow

Downflow Type Radiator

Tubes are mounted vertically as these radiators are designed to enable coolant to flow from the top tank downward to the bottom tank.

Downflow

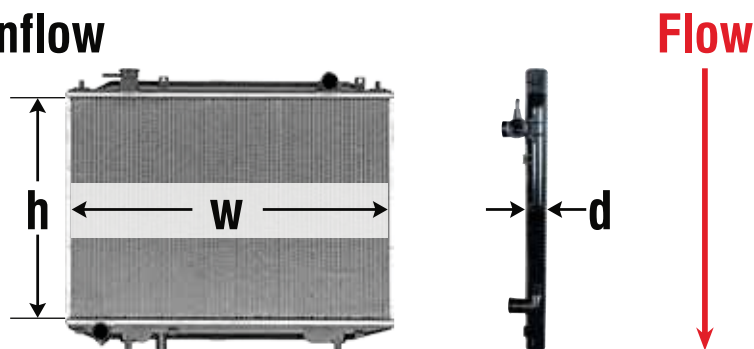

Crossflow Type Radiators

Tubes are mounted horizontally and the tanks are mounted on the sides as these radiators are designed to enable coolant to flow horizontally from tank to tank.

Crossflow

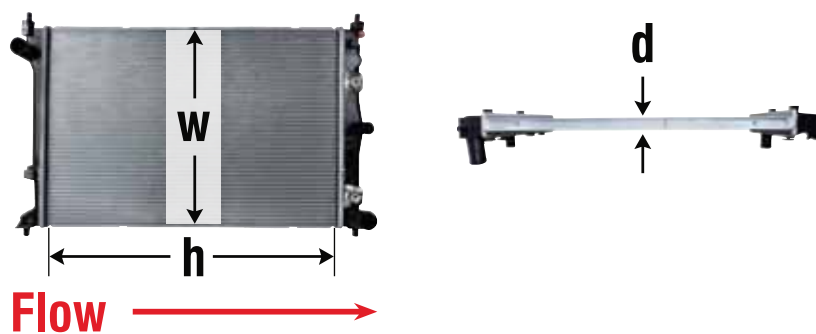

Key:

- H** = Core Height measurement is always taken from header to header between the two tanks, no matter how the radiator is positioned in the vehicle.
- W** = Core Width measurement is the distance between the side plates. (Not including the side plates)
- D** = Core Depth measurement is the thickness of the radiator core. Tip: Insert a wire between the fins until the end is flush with the other side of the core. Mark and measure the wire for the depth measurement.

Our range at your fingertips

**Create and manage specific vehicle lists
complete with available and fitted parts.**



Product Specification

With over 45,000 product images and 120,000 pieces of product data, Quantum Pro offers an unmatched product experience.

With Australasia's largest range finding your parts has never been easier.



Faster Vehicle Selection

We have improved the speed of our vehicle search to make finding parts even faster.

The new auto select option now only requires selection of necessary vehicle information to find specific products.



Filter Options

Search product categories by specific technical attributes. Quantum Pro allows you to apply up to 34 filters to ensure the part you have selected is right for the job at hand.

POWER THROUGH INFORMATION

QUANTUM PRO

www.quantumpro.com.au // www.quantumpro.co.nz



Testing for stray current has never been easier.

Introducing the OEX Stray Current Tester

Stray current can be extremely damaging to automotive cooling systems if left undiagnosed. In severe cases, stray current can cause extreme aluminium corrosion resulting in damage to radiators, water pumps and even engine blocks. Extensive damage can occur within weeks.

The OEX Stray Current Tester is specifically designed to accurately detect electrical current within vehicle cooling systems.



Part No. ACX100

Stray Current, commonly referred to as Electrolysis, is the premature deterioration of cooling system components caused by electrical current passing through the cooling system.

Electrolysis usually attacks the inner lining of radiator tubes. The tube material is systematically corroded due to improper grounding of the electrical components. Electrical grounding problems can be caused from poor installation of aftermarket accessories or incorrect installation of components after smash repairs.

Examples of damage caused by Stray Current:

1. Corrosion of tubes typically resulting in multiple holes
2. Build up of aluminium oxide blocking passages
3. White aluminium oxide powder visible through the inlet and outlet tubes.

Thanks to the advanced design and features of the OEX Stray Current Tester, checking for stray current has never been so easy. Please contact your Ashdown-Ingram representative for more information, or to order your Stray Current Tester today.



www.quantumpro.com.au

THE SPECIALIST'S CHOICE

MODEL	SERIES	ENGINE	TRANS	YEAR FROM	YEAR TO	RADIATOR OPTION 1	PAGE	RADIATOR OPTION 2	PAGE	CONDENSER OPTION 1	CONDENSER OPTION 2	RECEIVER DRIER OPTION 1	RECEIVER DRIER OPTION 2
ALFA ROMEO													
147	190	1.9L Turbo Diesel	Man	07-08	07-09	ALF66111	157						
147		2.0L Petrol	Man	09-01	07-09	ALF66081	157			CNX772			RDX281
147	JTD	1.9L Turbo Diesel	Man	01-06		ALF66111	157						
156		2.0L Petrol	Man	08-00	10-03	ALF18121	157			CNX779	CNX778		RDX281
156		2.5L Petrol	Auto	02-99	02-07	ALF18121	157			CNX779	CNX778		RDX281
156		2.5L Petrol	Man	02-02	07-06	ALF18121	157			CNX779	CNX778		RDX281
156		3.2L Petrol	Man	08-02	01-04	ALF66001	157			CNX779			RDX281
156	JTS	2.0L Petrol	Man	08-02	02-07	ALF18121	157			CNX779	CNX778		RDX281
166		3.0L Petrol	Auto	08-99	09-07	ALF66061	157						RDX281
AUDI													
80		2.0L Petrol	Auto	04-89	07-92	AUD11581	157						RDX375
80	B4	2.3L Petrol	Auto	07-92	10-93	AUD11581	157						RDX375
80	B4	2.6L Petrol	Auto	10-93	08-95	AUD15161	158						RDX375
80	B4	2.6L Petrol	Man	10-93	08-95	AUD14601	158						RDX375
80	B4	2.8L Petrol	Auto	07-92	11-94	AUD15161	158						RDX375
100	C4	2.6L Petrol	Auto	09-93	11-94	AUD15261	163						RDX375
100	C4	2.8L Petrol	Auto	01-92	11-94	AUD15261	163						RDX375
100 AVANT	C4	2.8L Petrol	Auto	06-93	11-94	AUD15261	163						RDX375
A3		1.6L Petrol	Auto	05-97	09-99	VW13781	159	VW81091	159	CNX860	CNX870		RDX378
A3		1.6L Petrol	Man	05-97	09-99	VW13781	159						RDX378
A3		1.8L Petrol	Man	05-97	09-99	VW13781	159			CNX860			RDX378
A3		2.0L Turbo Diesel	Man	02-06	10-07	VW65121	158			CNX870			RDX370
A3		2.0L Petrol	Man	06-04	01-06	VW81091	159			CNX870			RDX378

MODEL	SERIES	ENGINE	TRANS	YEAR FROM	YEAR TO	RADIATOR OPTION 1	PAGE	RADIATOR OPTION 2	PAGE	CONDENSER OPTION 1	CONDENSER OPTION 2	RECEIVER DRIER OPTION 1	RECEIVER DRIER OPTION 2
A3	8P	1.8L Turbo Petrol	Auto	01-10		VW74031	158			CNX870		RDx378	
A3	8P	1.8L Turbo Petrol	Man	01-07	12-08	VW74031	158			CNX870		RDx378	
A3	8P	2.0L Turbo Petrol	Auto	09-10		VW74031	158			CNX870		RDx378	
A3	ATTRACTION	1.6L Petrol	Auto	02-05	11-08	VW81091	159			CNX870		RDx378	
A3	ATTRACTION	1.6L Petrol	Man	06-04	11-08	VW81091	159			CNX870		RDx370	
A3	FSI	2.0L Petrol	Auto	06-04	05-08	VW81091	159			CNX870		RDx378	RDx370
A3	FSI	2.0L Petrol	Man	06-04	01-06	VW81091	159			CNX870		RDx370	
A3	FSI AMBITION	2.0L Petrol	Auto	02-05	05-08	VW81091	159			CNX870		RDx378	RDx370
A3	FSI AMBITION	2.0L Petrol	Man	02-05	05-08	VW81091	159			CNX870		RDx378	RDx370
A3	FSI ATTRACTION	2.0L Petrol	Auto	06-04	01-06	VW81091	159			CNX870		RDx370	
A3	SPORTSBACK ATTRACTION	1.6L Petrol	Man	11-08		VW81091	159						
A3	TDI	2.0L Turbo Diesel	Man	02-05		VW65121	158			CNX870		RDx370	
A3	TDI SPORTSBACK	1.9L Turbo Diesel	Man	02-08		VW65121	158			CNX870		RDx370	
A3	TFSI	1.8L Turbo Petrol	Man	05-07	12-08	VW74031	158			CNX870		RDx370	
A3	TFSI	2.0L Turbo Petrol	Man	02-05	12-08	VW74041	158			CNX870		RDx370	
A3	TFSI AMBITION	2.0L Turbo Petrol	Man	07-08		VW74031	158			CNX870		RDx370	
A3	TFSI ATTRACTION	1.6L Petrol	Man	11-08		VW81091	159			CNX870		RDx370	
A3	TFSI ATTRACTION	1.8L Turbo Petrol	Man	07-08		VW74031	158			CNX870		RDx370	
A3	TFSI SPORTSBACK	1.4L Turbo Petrol	Man	11-08		VW26701	158						
A3	TFSI SPORTSBACK AMBITION	1.8L Turbo Petrol	Man	11-08		VW74031	158			CNX870		RDx370	
A3	TURBO	1.8L Turbo Petrol	Man	09-99	06-04	VW13781	159			CNX860		RDx378	
A4	B5	1.8L Petrol	Auto	04-96	07-01	AUD16621	159					RDx375	
A4	B5	1.8L Turbo Petrol	Man	01-96	07-01	AUD16621	159	VW20591	159			RDx375	
A4	B5	2.4L Petrol	Auto	02-98	07-01	AUD16621	159	AUD20601	159			RDx375	
A4	B5	2.4L Petrol	Man	02-98	04-00	AUD15331	159			CNX561		RDx375	

MODEL	SERIES	ENGINE	TRANS	YEAR FROM	YEAR TO	RADIATOR OPTION 1	PAGE	RADIATOR OPTION 2	PAGE	CONDENSER OPTION 1	CONDENSER OPTION 2	RECEIVER DRIER OPTION 1	RECEIVER DRIER OPTION 2
AUDI (continued)													
A4	B5	2.6L Petrol	Auto	08-95	02-98	AUD16621	159	AUD20601	159	CNX561		RDX375	
A4	B5	2.6L Petrol	Man	08-95	02-98	AUD15331	159			CNX561		RDX375	
A4	B5	2.8L Petrol	Auto	01-97	07-01	AUD16621	159	AUD20601	159	CNX871		RDX375	
A4	B6	1.8L Turbo Petrol	Auto	01-03	01-07	AUD45631	160						
A4	B6	1.8L Turbo Petrol	Man	05-04	02-06	AUD16621	159	VW20591	159			RDX375	
A4	B6	2.0L Petrol	Auto	07-01	12-05	AUD17231	160			CNX562		RDX375	
A4	B6	2.0L Petrol	Man	07-01	12-05	AUD66261	161			CNX562		RDX375	
A4	B6	2.4L Petrol	Auto	04-02	12-05	AUD20601	159					RDX375	
A4	B6	3.0L Petrol	Auto	01-02	01-07	AUD15341	160						
A4	B6	3.0L Turbo Diesel	Auto	10-01	02-06	AUD15341	160						
A4	B7	1.8L Turbo Petrol	Auto	02-05	05-09	AUD17231	160			CNX562		RDX375	
A4	B7	1.8L Turbo Petrol	Man	02-05	05-09	AUD66261	161			CNX562		RDX375	
A4	B7	2.0L Petrol	Auto	02-05	05-09	AUD17231	160			CNX562		RDX375	
A4	B7	2.0L Turbo Petrol	Auto	05-05	05-08	AUD17231	160			CNX562		RDX375	
A4	B7	2.0L Turbo Diesel	Auto	10-05		AUD17231	160	AUD45631	160	CNX562		RDX375	
A4	B7	2.0L Turbo Petrol	Man	01-06	12-08	AUD45681	161	AUD53491	161				
A4	B7	2.0L Petrol	Man	02-05	05-09	AUD66261	161			CNX562		RDX375	
A4	B7	3.1L Petrol	Auto	01-07	01-10	AUD15341	160						
A4	B7	3.1L Petrol	Man	05-05	07-06	AUD15341	160						
A4	B8	1.8L Turbo Petrol	Man	05-08		AUD45681	161	AUD53491	161				
A4	B8	2.0L Turbo Diesel	Auto	04-08		AUD45631	160						
A4	B8	2.0L Turbo Diesel	Man	01-10		AUD45681	161	AUD53491	161				
A4	B8	2.0L Turbo Petrol	Man	05-09		AUD45681	161	AUD45631	160				
A4	B8 TFSI	1.8L Turbo Petrol	Auto	05-08		AUD17231	160	AUD45631	160	CNX562		RDX375	

MODEL	SERIES	ENGINE	TRANS	YEAR FROM	YEAR TO	RADIATOR OPTION 1	PAGE	RADIATOR OPTION 2	PAGE	CONDENSER OPTION 1	CONDENSER OPTION 2	RECEIVER DRIER OPTION 1	RECEIVER DRIER OPTION 2
A4	B8 TFSI	2.0L Turbo Petrol	Auto	11-08		AUD45631	160						
A4	B8 TFSI	2.0L Turbo Petrol	Man	11-08		AUD45581	161	AUD53491	161				
A4 AVANT	B5	1.8L Petrol	Auto	01-97	04-00	AUD16621	159	AUD20601	159			RDX375	
A4 AVANT	B5	1.8L Turbo Petrol	Auto	05-99	07-02	VW20591	159			CNX864		RDX375	
A4 AVANT	B5	1.8L Petrol	Man	01-97	04-00	AUD16621	159	AUD20601	159			RDX375	
A4 AVANT	B5	1.8L Turbo Petrol	Man	01-98	07-02	AUD16621	159			CNX864		RDX375	
A4 AVANT	B5	2.4L Petrol	Auto	02-98	07-02	AUD20601	159			CNX864		RDX375	
A4 AVANT	B5	2.6L Petrol	Auto	10-96	02-98	AUD20601	159			CNX561		RDX375	
A4 AVANT	B5	2.6L Petrol	Man	10-96	02-98	AUD15331	159	VW20591	159	CNX561		RDX375	
A4 AVANT	B6	1.8L Turbo Petrol	Man	05-04	02-06	VW13781	159					RDX375	
A4 AVANT	B6	2.0L Petrol	Auto	09-02	02-06	AUD17231	160			CNX562		RDX375	
A4 AVANT	B7	1.8L Turbo Petrol	Auto	02-05	08-08	AUD17231	160			CNX562		RDX375	
A4 AVANT	B7	2.0L Turbo Petrol	Auto	05-05	08-08	AUD17231	160			CNX562		RDX375	
A4 AVANT	B7	2.0L Turbo Petrol	Man	02-06	10-06	AUD66261	161			CNX562		RDX375	
A4 AVANT	B8 TDI	2.0L Turbo Diesel	Auto	08-08		AUD45631	160						
A4 AVANT	B8 TFSI	1.8L Turbo Petrol	Auto	08-08		AUD45631	160						
A4 AVANT	B8 TFSI	2.0L Turbo Petrol	Auto	02-09		AUD45631	160						
A4 AVANT	B8 TFSI	2.0L Turbo Petrol	Man	05-09		AUD45581	161						
A5	F5I	3.2L Petrol	Auto	09-07		AUD45631	160					RDX372	
A5	F5I	3.2L Petrol	Man	08-09		AUD45581	161	AUD53491	161			RDX372	
A5	QUATTRO	3.2L Petrol	Auto	05-08		AUD45631	160					RDX372	
A5	TDI	3.0L Turbo Diesel	Auto	12-08		AUD45631	160					RDX372	
A5	TDI	3.0L Turbo Diesel	Man	08-09		AUD45581	161	AUD53491	161			RDX372	
A5	TFSI	2.0L Turbo Petrol	Auto	09-09		AUD45631	160					RDX372	
A5	TFSI	2.0L Turbo Petrol	Man	05-09		AUD45631	160	AUD53491	161			RDX372	

MODEL	SERIES	ENGINE	TRANS	YEAR FROM	YEAR TO	RADIATOR OPTION 1	PAGE	RADIATOR OPTION 2	PAGE	CONDENSER OPTION 1	CONDENSER OPTION 2	RECEIVER DRIER OPTION 1	RECEIVER DRIER OPTION 2
AUDI (continued)													
A6		2.4L Petrol	Auto	10-04	09-08	AUD20601	159						
A6		2.6L Petrol	Auto	11-94	10-97	AUD15261	163					RDX375	
A6		2.8L Petrol	Auto	01-97	10-99	AUD20601	159					RDX375	
A6		2.8L Petrol	Auto	10-07	02-09	AUD20601	159						
A6		3.1L Petrol	Auto	06-05	02-09	AUD15341	160						
A6	4B	2.4L Petrol	Auto	02-02	10-04	AUD20601	159			CNX562		RDX375	
A6	4B	3.0L Petrol	Auto	02-02	06-05	AUD15341	160						
A6	C5	2.4L Petrol	Auto	11-97	02-02	AUD20601	159					RDX375	
A6	C5	2.8L Petrol	Auto	01-97	02-02	AUD20601	159					RDX375	
A6	C7	2.0L Turbo Petrol	Auto	09-06		AUD20601	159						
A6	FSI	2.8L Petrol	Auto	02-09		AUD20601	159						
A6	QUATTRO	4.2L Petrol	Auto	10-04	02-09	AUD15261	163	AUD19091	163				
A6 AVANT		2.4L Petrol	Auto	07-05	10-06	AUD20601	159			CNX886			
A6 AVANT		2.6L Petrol	Auto	11-94	02-98	AUD15261	163			CNX886		RDX375	
A6 AVANT		3.1L Petrol	Auto	02-06	02-09	AUD15341	160			CNX886			
A6 AVANT	C5	2.4L Petrol	Auto	12-98	02-02	AUD20601	159			CNX874		RDX375	
A6 AVANT	C5	2.8L Petrol	Auto	12-98	02-02	AUD20601	159			CNX874		RDX375	
A8		2.8L Petrol	Auto	05-95	01-97	AUD15331	159						
A8		3.7L Petrol	Auto	06-03	10-06	AUD19091	163						
A8		4.2L Petrol	Auto	08-03		AUD19091	163						
A8		4.2L Petrol	Auto	08-04	07-05	AUD19091	163						
CABRIOLET		2.6L Petrol	Auto	01-94	12-99	AUD15161	158						
CABRIOLET	B6	3.0L Petrol	Auto	12-02	06-06	AUD15341	160						
CABRIOLET	B7	3.1L Petrol	Auto	10-07		AUD15341	160						

MODEL	SERIES	ENGINE	TRANS	YEAR FROM	YEAR TO	RADIATOR OPTION 1	PAGE	RADIATOR OPTION 2	PAGE	CONDENSER OPTION 1	CONDENSER OPTION 2	RECEIVER DRIER OPTION 1	RECEIVER DRIER OPTION 2
Q7		3.0L Turbo Diesel	Auto	08-06	10-08	AUD19001	164		164	CNX910		RDX922	
Q7		4.1L Turbo Diesel	Auto	10-07	10-09	AUD19001	164		164	CNX910		RDX922	
Q7		4.2L Petrol	Auto	08-06		AUD19001	164		164	CNX910		RDX922	
Q7		5.9L Diesel	Auto	11-09		AUD19001	164		164	CNX910		RDX922	
Q7	FSI	3.6L Petrol	Auto	08-06		AUD19001	164		164	CNX910		RDX922	
Q7	FSI	4.2L Petrol	Auto	10-08		AUD19001	164		164	CNX910		RDX922	
Q7	TDI	3.0L Turbo Diesel	Auto	10-08		AUD19001	164		164	CNX910		RDX922	
Q7	TDI	4.1L Diesel	Auto	09-10		AUD19001	164		164	CNX910		RDX922	
Q7	TDI	4.1L Turbo Diesel	Auto	10-08		AUD19001	164		164	CNX910		RDX922	
Q7	TFSI	3.0L Petrol	Auto	09-10		AUD19001	164		164	CNX910		RDX922	
S3		1.8L Turbo Petrol	Man	11-99	06-04	VW13781	159		159				
TT		1.8L Turbo Petrol	Auto	01-03	10-06	VW13781	159		159				
TT		1.8L Turbo Petrol	Man	05-99	10-06	VW13781	159		159			RDX378	
TT		2.0L Turbo Petrol	Man	10-06		VW74031	158		158				
TT	QUATTRO	1.8L Turbo Petrol	Man	05-00	10-06	VW13781	159		159				
TT	TFSI	2.0L Turbo Petrol	Man	07-09		VW74031	158		158				
BMW													
116i	E87	1.6L Petrol	Man	02-05	06-07	BMW54061	165	D1CM	165				
118D	E87	2.0L Turbo Diesel	Auto	09-09		BMW54031	165		165	CNX697		RDX058	
118D	E87	2.0L Turbo Diesel	Man	09-09		BMW54031	165		165	CNX697		RDX058	
118D	E88	2.0L Turbo Diesel	Auto	09-09		BMW54031	165		165				
118D	E88	2.0L Turbo Diesel	Man	09-09		BMW54031	165		165				
118i	E87	2.0L Petrol	Auto	09-04	02-08	BMW54071	165	D1CA	165	CNX697		RDX058	
118i	E87	2.0L Petrol	Man	03-07		BMW54061	165	D1CM	165				
120D	E87	2.0L Turbo Diesel	Auto	03-07	12-09	BMW54031	165	D1CA	165	CNX697		RDX058	

MODEL	SERIES	ENGINE	TRANS	YEAR FROM	YEAR TO	RADIATOR OPTION 1	PAGE	RADIATOR OPTION 2	PAGE	CONDENSER OPTION 1	CONDENSER OPTION 2	RECEIVER DRIER OPTION 1	RECEIVER DRIER OPTION 2
BMW (continued)													
120D	E87	2.0L Turbo Diesel	Man	03-09	12-09	BMW54031	165			CNX697			RDX058
120i	E87	2.0L Petrol	Auto	09-04	02-08	BMW54071	165	D1CA	165	CNX697			RDX058
120i	E87	2.0L Petrol	Man	09-04	02-08	BMW54061	165	D1CM	165				
120i	E88	2.0L Petrol	Auto	05-08		BMW54071	165	D1CA	165	CNX697			RDX058
120i	E88	2.0L Petrol	Man	05-08		BMW54061	165	D1CM	165				
123D	E82	2.0L Turbo Diesel	Auto	09-09		BMW54031	165			CNX697			
123D	E82	2.0L Turbo Diesel	Man	09-09		BMW54031	165			CNX697			
123D	E87	2.0L Turbo Diesel	Auto	09-09		BMW54031	165					RDX058	
123D	E87	2.0L Turbo Diesel	Man	09-09		BMW54031	165					RDX058	
123D	E88	2.0L Turbo Diesel	Auto	09-09		BMW54031	165						
123D	E88	2.0L Turbo Diesel	Man	09-09		BMW54031	165						
125i		3.0L Petrol	Auto	05-08		BMW54071	165	D1CA	165	CNX697			RDX058
125i		3.0L Petrol	Man	05-08		BMW54061	165	D1CM	165				
130i	E87	3.0L Petrol	Auto	02-06	12-09	BMW54071	165	D1CA	165	CNX697			RDX058
130i	E87	3.0L Petrol	Man	11-05	12-09	BMW54061	165	D1CM	165				
135i		3.0L Turbo Petrol	Auto	05-08		BMW54071	165	D1CA	165	CNX697			RDX058
135i		3.0L Turbo Petrol	Man	05-08		BMW54061	165	D1CM	165				
135i	E82	3.0L Turbo Petrol	Auto	05-10		BMW54071	165	D1CA	165	CNX697			RDX058
135i	E82	3.0L Turbo Petrol	Man	05-10		BMW54061	165	D1CM	165				
316i	E36	1.6L Petrol	Auto	03-95	05-96	BMW11571	166	BMW13251	166	CNX620			RDX045
316i	E36	1.6L Petrol	Man	03-95	05-96	BMW11571	166	BMW13121	166	CNX620			RDX045
316i	E36	1.9L Petrol	Auto	05-96	02-02	BMW11571	166	BMW13251	166	CNX623			RDX056
316i	E36	1.9L Petrol	Man	05-96	02-02	BMW11571	166	BMW13121	166	CNX623			RDX056
316i	E46	1.8L Petrol	Auto	02-02	01-06	BMW16251	166	BMW16271	166	CNX630			RDX055

MODEL	SERIES	ENGINE	TRANS	YEAR FROM	YEAR TO	RADIATOR OPTION 1	PAGE	RADIATOR OPTION 2	PAGE	CONDENSER OPTION 1	CONDENSER OPTION 2	RECEIVER DRIER OPTION 1	RECEIVER DRIER OPTION 2
316i	E46	1.8L Petrol	Man	02-02	01-06	BMW16241	166			CNX630		RD055	
316i	E30	1.8L Petrol	Auto	01-80	06-85	BMW13261	167					RD043	
318i	E30	1.8L Petrol	Auto	07-85	01-91	BMW11571	166	BMW13251	166	CNX621		RD040	RD043
318i	E30	1.8L Petrol	Auto	11-88	02-92	BMW11571	166			CNX621		RD040	
318i	E30	1.8L Petrol	Man	10-83	12-87	BMW13261	167					RD043	
318i	E30	1.8L Petrol	Man	11-88	02-92	BMW11571	166	BMW13121	166	CNX621		RD040	
318i	E36	1.8L Petrol	Auto	05-91	08-98	BMW11571	166			CNX623		RD047	
318i	E36	1.8L Petrol	Man	05-91	08-98	BMW11571	166	BMW13121	166	CNX623		RD047	
318i	E46	1.9L Petrol	Auto	08-98	10-01	BMW16251	166	BMW16271	166	CNX630		RD055	
318i	E46	1.9L Petrol	Man	08-98	10-01	BMW16241	166			CNX630		RD055	
318i	E46	2.0L Petrol	Auto	10-01	12-05	BMW16251	166	BMW16271	166	CNX630		RD055	
318i	E46	2.0L Petrol	Man	04-04	05-05	BMW16241	166			CNX630		RD055	
318i	E46	2.0L Petrol	Man	10-01	12-05	BMW16241	166			CNX630		RD055	
318i-S	E30	1.8L Petrol	Man	05-83	12-91	BMW13261	167					RD043	
318is	E36	1.8L Petrol	Auto	06-93	06-97	BMW11571	166	BMW13251	166	CNX620		RD040	
318is	E36	1.8L Petrol	Man	05-92	06-97	BMW11571	166	BMW13121	166	CNX620		RD040	
318is	E36	1.9L Petrol	Auto	06-96	06-99	BMW11571	166	BMW13251	166	CNX620		RD045	
318is	E36	1.9L Petrol	Man	06-96	06-99	BMW11571	166	BMW13121	166	CNX620		RD045	
318i	E36	1.8L Petrol	Auto	01-94	12-97	BMW11571	166						
318i	E36	1.9L Petrol	Auto	05-96	02-02	BMW11571	166	BMW13251	166	CNX623		RD056	
318i	E36	1.9L Petrol	Man	05-96	02-02	BMW11571	166	BMW13121	166	CNX623		RD056	
318i	E46	1.9L Petrol	Auto	01-96	12-01	BMW16271	166						
318i	E46	2.0L Petrol	Auto	02-02	01-06	BMW16251	166	BMW16271	166	CNX630		RD055	
318i	E46	2.0L Petrol	Man	02-02	01-06	BMW16241	166			CNX630		RD055	
320Ci	E46	2.2L Petrol	Auto	01-00	09-06	BMW16251	166	BMW16271	166	CNX630		RD055	
320Ci	E46	2.2L Petrol	Man	01-00	09-06	BMW16241	166			CNX630		RD055	

MODEL	SERIES	ENGINE	TRANS	YEAR FROM	YEAR TO	RADIATOR OPTION 1	PAGE	RADIATOR OPTION 2	PAGE	CONDENSER OPTION 1	CONDENSER OPTION 2	RECEIVER DRIER OPTION 1	RECEIVER DRIER OPTION 2
BMW (continued)													
320D	E90	2.0L Turbo Diesel	Auto	02-06		BMW54031	165			CNX697			RDY058
320D	E91	2.0L Turbo Diesel	Auto	09-09		BMW54031	165			CNX697			RDY058
320i	E30	2.0L Petrol	Auto	02-88	02-91	BMW10611	169			CNX621			RDY047
320i	E30	2.0L Petrol	Man	01-76	12-88	BMW13121	166	BMW17221	167	CNX621			RDY047
320i	E36	2.0L Petrol	Auto	05-91	01-96	BMW13091	168	BMW13251	166	CNX620			RDY045
320i	E36	2.0L Petrol	Man	05-91	01-96	BMW13091	168	BMW13121	166	CNX620			RDY045
320i	E46	2.2L Petrol	Auto	11-00	05-06	BMW16251	166	BMW16271	166	CNX630			RDY055
320i	E46	2.2L Petrol	Man	11-00	05-06	BMW16241	166			CNX630			RDY055
320i	E90	2.0L Petrol	Auto	05-05		BMW54071	165	D1CA	165	CNX697			RDY058
320i	E90	2.0L Petrol	Man	05-05	01-09	BMW54061	165	D1CM	165				
320i	E91	2.0L Petrol	Auto	09-07	10-08	BMW54071	165	D1CA	165	CNX697			RDY058
320i	E91	2.0L Petrol	Man	09-07		BMW54061	165	D1CM	165				
323Ci	E46	2.5L Petrol	Auto	06-99	10-00	BMW16251	166	BMW16271	166	CNX630			RDY055
323Ci	E46	2.5L Petrol	Man	06-99	10-00	BMW16241	166			CNX630			RDY055
323i	E30	2.3L	Man	03-82	01-86	BMW13121	166						
323i	E36	2.5L Petrol	Auto	01-96	08-98	BMW11571	166	BMW13251	166	CNX620			RDY045
323i	E36	2.5L Petrol	Man	01-96	08-98	BMW13091	168	BMW13121	166	CNX620			RDY045
323i	E46	2.5L Petrol	Auto	08-98	10-00	BMW16251	166	BMW16271	166	CNX630			RDY055
323i	E46	2.5L Petrol	Man	08-98	10-00	BMW16241	166			CNX630			RDY055
323i	E90	2.5L Petrol	Auto	02-06	02-08	BMW54071	165	D1CA	165	CNX697			RDY058
323i	E90	2.5L Petrol	Man	02-06	02-08	BMW54061	165	D1CM	165				
323i	E91	2.5L Petrol	Auto	02-06	02-08	BMW54071	165	D1CA	165	CNX697			RDY058
323i	E91	2.5L Petrol	Man	03-07		BMW54061	165	D1CM	165				
323i	E92	2.5L Petrol	Auto	09-06	12-09	BMW54071	165	D1CA	165	CNX697			RDY058

MODEL	SERIES	ENGINE	TRANS	YEAR FROM	YEAR TO	RADIATOR OPTION 1	PAGE	RADIATOR OPTION 2	PAGE	CONDENSER OPTION 1	CONDENSER OPTION 2	RECEIVER DRIER OPTION 1	RECEIVER DRIER OPTION 2
323i	E92	2.5L Petrol	Man	09-06	12-09	BMW54061	165	D1CM	165				
325Ci	E46	2.5L Petrol	Auto	01-00	09-06	BMW16251	166	BMW16271	166	CNX630		RDX055	
325Ci	E46	2.5L Petrol	Man	01-00	09-06	BMW16241	166			CNX630		RDX055	
325E	E30	2.7L Petrol	Auto	01-86	12-87	BMW13251	166	BMW13191	169			RDX043	
325E	E30	2.7L Petrol	Man	01-86	12-87	BMW13261	167					RDX043	
325i	E30	2.5L Petrol	Auto	01-88	03-91	BMW10611	169			CNX621		RDX047	
325i	E30	2.5L Petrol	Man	01-88	02-92	BMW13121	166			CNX621		RDX047	
325i	E36	2.5L Petrol	Auto	05-91	05-96	BMW11571	166	BMW13251	166	CNX620		RDX045	
325i	E36	2.5L Petrol	Man	02-94	05-96	BMW13091	168	BMW13121	166	CNX620		RDX045	
325i	E36	2.5L Petrol	Man	05-92	05-96	BMW13091	168	BMW13121	166	CNX620		RDX045	
325i	E46	2.5L Petrol	Auto	11-00	05-06	BMW16251	166	BMW16271	166	CNX630		RDX055	
325i	E46	2.5L Petrol	Man	11-00	05-06	BMW16241	166			CNX630		RDX055	RDX057
325i	E90	2.5L Petrol	Auto	05-05		BMW54071	165	D1CA	165	CNX697		RDX058	
325i	E90	2.5L Petrol	Man	05-05	01-09	BMW54061	165	D1CM	165				
325i	E92	2.5L Petrol	Auto	09-06		BMW54071	165	D1CA	165	CNX697		RDX058	
325i	E92	2.5L Petrol	Man	09-06		BMW54061	165	D1CM	165				
325i	E93	2.5L Petrol	Auto	03-07	12-11	BMW54071	165	D1CA	165	CNX697		RDX058	
325i	E93	2.5L Petrol	Man	03-07		BMW54061	165	D1CM	165				
325is	E30	2.5L Petrol	Auto	09-88	12-91	BMW10611	169			CNX621		RDX047	
325Ti	E46	2.5L Petrol	Auto	05-02	01-06	BMW16251	166	BMW16271	166			RDX057	
325Ti	E46	2.5L Petrol	Man	05-02	02-04	BMW16241	166					RDX057	
328Ci	E46	2.8L Petrol	Auto	01-97	09-00	BMW16251	166	BMW16271	166	CNX630		RDX055	
328Ci	E46	2.8L Petrol	Man	01-97	09-00	BMW16241	166			CNX630		RDX055	
328i	E36	2.8L Petrol	Auto	06-93	12-99	BMW11571	166	BMW13251	166	CNX620		RDX045	
328i	E36	2.8L Petrol	Man	06-95	01-97	BMW13091	168	BMW13121	166	CNX620		RDX045	

MODEL	SERIES	ENGINE	TRANS	YEAR FROM	YEAR TO	RADIATOR OPTION 1	PAGE	RADIATOR OPTION 2	PAGE	CONDENSER OPTION 1	CONDENSER OPTION 2	RECEIVER DRIER OPTION 1	RECEIVER DRIER OPTION 2
BMW (continued)													
328i	E46	2.8L Petrol	Auto	01-97	09-00	BMW16251	166	BMW16271	166	CNX630			RDx055
330Ci	E46	3.0L Petrol	Auto	09-00	03-07	BMW16251	166	BMW16271	166	CNX630			RDx055
330Ci	E46	3.0L Petrol	Man	09-00	02-04	BMW16241	166			CNX630			RDx055
330i	E46	3.0L Petrol	Auto	09-00	05-06	BMW16251	166	BMW16271	166	CNX630			RDx055
330i	E90	3.0L Petrol	Auto	05-05	01-07	BMW54071	165	D1CA	165	CNX697			RDx058
335i	E90	3.0L Turbo Petrol	Auto	10-06	01-08	BMW54071	165	D1CA	165	CNX697			RDx058
335i	E91	3.0L Turbo Petrol	Auto	09-07		BMW54031	165			CNX697			RDx058
335i	E93	3.0L Turbo Petrol	Man	10-08		BMW19131	169			CNX697			
520D	F11	2.0L Turbo Diesel	Auto	09-10		BMW55381	169						
520i	E28	2.0L Petrol	Auto	11-83	12-85	BMW13191	169			CNX624			RDx043
520i	E34	2.0L Petrol	Auto	11-90	07-96	BMW13101	170			CNX625			RDx044
523i	E39	2.5L Petrol	Auto	05-96	01-01	BMW12231	170			CNX620			RDx051
525	E60	3.0L Petrol	Auto	04-07	10-08	BMW45761	170						
523i	E60	2.5L Petrol	Auto	04-07		BMW18001	170	BMW19131	169				
525E	E28	2.7L Petrol	Auto	01-86	08-88	BMW13191	169			CNX624			RDx042
525i	E34	2.5L Petrol	Auto	09-88	11-90	BMW13101	170			CNX625			RDx044
525i	E34	2.5L Petrol	Man	09-88	12-92	BMW13081	170						RDx044
525i	E39	2.5L Petrol	Auto	01-01	10-03	BMW10301	170	BMW12231	170	CNX620			RDx051
525i	E60	2.5L Petrol	Auto	10-03	05-06	BMW18001	170	BMW45761	170	CNX694			RDx054
525i	E60	3.0L Petrol	Auto	04-07	10-08	BMW45761	170						
525i TOURING	E34	2.5L Petrol	Auto	05-92	09-96	BMW13101	170			CNX625			RDx044
525i TOURING	E34	2.5L Petrol	Man	05-92	05-94	BMW13101	170			CNX625			RDx044
528i	E39	2.8L Petrol	Auto	05-96	01-01	BMW12231	170			CNX620			RDx051
528i	F10	3.0L Petrol	Auto	05-10		BMW55381	169						
530	E60	3.0L Petrol	Auto	04-07	10-08	BMW45761	170						

MODEL	SERIES	ENGINE	TRANS	YEAR FROM	YEAR TO	RADIATOR OPTION 1	PAGE	RADIATOR OPTION 2	PAGE	CONDENSER OPTION 1	CONDENSER OPTION 2	RECEIVER DRIER OPTION 1	RECEIVER DRIER OPTION 2
530i	E34	3.0L Petrol	Auto	05-93	12-96	BMW12511	171	BMW11501	171	CNX625		RDX044	
530i	E39	3.0L Petrol	Auto	01-01	01-05	BMW19131	169			CNX620		RDX051	
530i	E60	3.0L Petrol	Auto	04-07		BMW45761	170			CNX694			
530i	E60	3.0L Petrol	Auto	10-03	05-06	BMW18001	170	BMW19131	169				
535D	F10	3.0L Diesel	Auto	09-10		BMW55381	169						
535i	E34	3.4L Petrol	Auto	09-88	05-94	BMW13071	171			CNX625		RDX044	
535i	E39	3.5L Petrol	Auto	12-96	10-03	BMW12491	171	BMW12511	171	CNX620		RDX051	
535i	F07	3.0L Petrol	Auto	02-10		BMW55381	169						
535i	F10	3.0L Petrol	Auto	02-10		BMW55381	169						
535i	F11	3.0L Petrol	Auto	02-10		BMW55381	169						
540i	E34	4.0L Petrol	Auto	05-93	12-96	BMW12511	171			CNX625		RDX044	
540i	E34	4.0L Petrol	Man	11-94	12-96	BMW12491	171			CNX620		RDX051	
540i	E39	4.4L Petrol	Auto	12-96	10-03	BMW12231	170	BMW12491	171	CNX620		RDX051	
540i	E60	4.0L Petrol	Auto	10-05	01-08	BMW19131	169						
545i	E60	4.4L Petrol	Auto	10-03	01-06	BMW18001	170	BMW19131	169	CNX694		RDX054	
550i	E60	4.8L Petrol	Auto	10-05		BMW19131	169						
550i	F07	4.4L Petrol	Auto	02-10		BMW55381	169						
550i	F10	4.4L Petrol	Auto	02-10	10-11	BMW55381	169						
645Ci	E63	4.4L Petrol	Auto	02-04	12-05	BMW18001	170			CNX694			
645Ci	E63	4.4L Petrol	Man	02-04	12-05	BMW18001	170						
645Ci	E64	4.4L Petrol	Auto	02-04	12-05	BMW18001	170						
645Ci	E64	4.4L Petrol	Man	02-04	12-05	BMW18001	170			CNX694			
650i	E63	4.8L Petrol	Auto	12-05		BMW18001	170	BMW19131	169				
650i	E63	4.8L Petrol	Man	12-05	09-07	BMW18001	170						
650i	E64	4.8L Petrol	Auto	12-05		BMW18001	170	BMW19131	169				

MODEL	SERIES	ENGINE	TRANS	YEAR FROM	YEAR TO	RADIATOR OPTION 1	PAGE	RADIATOR OPTION 2	PAGE	CONDENSER OPTION 1	CONDENSER OPTION 2	RECEIVER DRIER OPTION 1	RECEIVER DRIER OPTION 2
BMW (continued)													
650I	E64	4.8L Petrol	Man	12-05	09-07	BMW18001	170						
730I	E32	3.0L Petrol	Auto	11-90	01-93	BMW13071	171			CNX625			RD044
730LL	E32	3.0L Petrol	Auto	10-92	02-95	BMW13091	168	BMW11501	171	CNX625			RD044
730LL	E38	3.0L Petrol	Auto	02-95	06-97	BMW12511	171	BMW11501	171	CNX818			RD046
735I	E23	2.3L		05-83	01-88	BMW13071	171						
735I	E32	3.4L Petrol	Auto	03-87	12-90	BMW13071	171						RD044
735I	E38	3.5L Petrol	Auto	10-98	02-02	BMW12231	170	BMW12491	171	CNX818			RD046
735I	E65	3.6L Petrol	Auto	02-02	03-06	BMW18001	170			CNX694			
735LL	E32	3.4L Petrol	Auto	03-87	11-92	BMW13071	171						
735LL	E38	3.5L Petrol	Auto	06-96	02-02	BMW12231	170	BMW12491	171	CNX818			RD046
735LI	E66	3.6L Petrol	Auto	07-02	03-06	BMW18001	170	BMW19131	169				
740I	E65	4.0L Petrol	Auto	03-05	03-09	BMW55381	169			CNX818			RD046
740-LI	F01-02	3.0L Turbo Petrol	Auto	03-09	12-11	BMW55381	169			CNX818			RD046
740LL	E32	4.0L Petrol	Auto	10-92	02-95	BMW12511	171			CNX818			RD046
740LL	E38	4.0L Petrol	Auto	01-93	12-00	BMW12231	170	BMW12511	171	CNX818			RD046
740LL	E38	4.4L Petrol	Auto	06-96	01-02	BMW12231	170	BMW12491	171	CNX818			RD046
740LI	E66	4.0L Petrol	Auto	03-05	03-09	BMW19131	169			CNX818			
745I	E65	4.4L Petrol	Auto	02-02	03-06	BMW18001	170	BMW19131	169	CNX694			
745LI	E66	4.4L Petrol	Auto	07-02	03-06	BMW18001	170	BMW19131	169				
750I	E65	4.8L Petrol	Auto	03-05	03-09	BMW19131	169			CNX887			
750-LI	F01-02	4.4L Turbo Petrol	Auto	03-09		BMW19131	169			CNX887			
750LL	E32	5.0L Petrol	Auto	01-88	02-95	BMW18001	170	BMW19131	169				
750LL	E38	5.4L Petrol	Auto	05-95	01-02	BMW12231	170	BMW12511	171	CNX818			RD046
750LI	E66	4.8L Petrol	Auto	03-05	03-09	BMW19131	169						

MODEL	SERIES	ENGINE	TRANS	YEAR FROM	YEAR TO	RADIATOR OPTION 1	PAGE	RADIATOR OPTION 2	PAGE	CONDENSER OPTION 1	CONDENSER OPTION 2	RECEIVER DRIER OPTION 1	RECEIVER DRIER OPTION 2
760LI	E66	6.0L Petrol	Auto	03-03	03-09	BMW18001	170						
760LI	F02	6.0L Turbo Petrol	Auto	09-09		BMW55381	169						
L7	E38	5.4L Petrol	Auto	10-98	01-02	BMW12231	170	BMW12511	171	CNX618		RDX046	
M3	E36	2.0L Petrol	Man	04-95	04-97	BMW13121	166			CNX620		RDX045	
M3	E36	3.2L Petrol	Man	04-96	12-02	BMW12211	174	BMW13091	168	CNX623		RDX045	
M3	E46	3.2L Petrol	Man	01-01	08-06	BMW16241	166			CNX630		RDX055	
M3	E90	4.0L Petrol	Auto	11-10		BMW54071	165	D1CA	165	CNX697		RDX058	
M5	E39	4.9L Petrol	Man	05-99	10-03	BMW12501	174						
X1	E84	3.0L Petrol	Auto	03-10		BMW54071	165	D1CA	165	CNX697		RDX058	
X3	E83	2.5L Petrol	Auto	05-04	10-06	BMW13071	171			CNX639			
X3	E83	2.5L Petrol	Man	05-04	10-06	BMW12211	174			CNX639		RDX057	
X3	E83	3.0L Petrol	Auto	05-04	10-06	BMW13071	171			CNX638			
X3	E83	3.0L Turbo Diesel	Auto	12-05	12-08	BMW18751	176			CNX638			
X5	E53	2.9L Turbo Diesel	Auto	03-03	12-03	BMW18751	176			CNX632			
X5	E53	2.9L Turbo Diesel	Man	03-03	12-03	BMW18751	176			CNX632			
X5	E53	3.0L Turbo Diesel	Auto	01-04	03-07	BMW18751	176			CNX632		RDX058	
X5	E53	3.0L Petrol	Auto	03-01	11-03	BMW18751	176	BMW13071	171	CNX632		RDX058	
X5	E53	3.0L Turbo Diesel	Man	01-04	03-07	BMW18751	176			CNX632		RDX058	
X5	E53	3.0L Petrol	Man	03-01	11-03	BMW18751	176			CNX632		RDX058	
X5	E53	4.4L Petrol	Auto	01-00	03-07	BMW18751	176			CNX632			
X5	E53	4.6L Petrol	Auto	10-01	11-03	BMW18751	176			CNX632			
X5	E53	4.8L Petrol	Auto	02-04	03-07	BMW18751	176			CNX632			
X6	E71	3.0L Diesel	Auto	02-08		BMW18751	176						
X6	E71	3.0L Turbo Diesel	Auto	02-08		BMW18751	176						
X6	E71	4.4L Petrol	Auto	10-08		BMW18751	176						
Z3	E36	1.9L Petrol	Auto	01-97	06-99	BMW11571	166	BMW13251	166	CNX623		RDX045	

Vehicle Application Guide

MODEL	SERIES	ENGINE	TRANS	YEAR FROM	YEAR TO	RADIATOR OPTION 1	PAGE	RADIATOR OPTION 2	PAGE	CONDENSER OPTION 1	CONDENSER OPTION 2	RECEIVER DRIER OPTION 1	RECEIVER DRIER OPTION 2
BMW (continued)													
Z3	E36	1.9L Petrol	Man	01-97	06-99	BMW11571	166	BMW13121	166	CNX623		RDx045	
Z3	E36	2.0L Petrol	Auto	06-99	10-00	BMW11571	166	BMW13251	166	CNX623		RDx056	
Z3	E36	2.0L Petrol	Man	06-99	10-00	BMW11571	166	BMW13121	166	CNX623		RDx056	
Z3	E36	2.2L Petrol	Auto	10-00	03-03	BMW11571	166	BMW13251	166	CNX623		RDx056	
Z3	E36	2.2L Petrol	Man	10-00	03-03	BMW11571	166	BMW13121	166	CNX623		RDx056	
Z3	E36	2.8L Petrol	Auto	09-97	06-00	BMW11571	166	BMW13251	166	CNX623		RDx056	
Z3	E36	2.8L Petrol	Man	09-97	06-00	BMW11571	166	BMW13121	166	CNX623		RDx056	
Z3	E36	3.0L Petrol	Auto	08-00	03-03	BMW11571	166	BMW13251	166	CNX623		RDx056	
Z3	E36	3.0L Petrol	Man	08-00	03-03	BMW11571	166	BMW13121	166	CNX623		RDx056	
Z4	E85	2.5L Petrol	Auto	03-03	12-09	BMW16251	166	BMW16271	166				
Z4	E85	2.5L Petrol	Man	03-03	12-09	BMW16241	166						
Z4	E85	3.0L Petrol	Auto	01-06	05-10	BMW16251	166	BMW16271	166				
Z4	E85	3.0L Petrol	Man	03-03	05-10	BMW16241	166						
Z4	E85	3.3L Petrol	Man	04-06	05-10	BMW16241	166						
Z4	E86	3.0L Petrol	Auto	01-07	05-10	BMW16251	166	BMW16271	166				
Z4	E86	3.0L Petrol	Man	01-07	05-10	BMW16241	166						
Z4	E86	3.3L Petrol	Man	07-06	05-10	BMW16241	166						
Z4	E89	2.5L Petrol	Auto	05-09		BMW16251	166	BMW16271	166				
Z4	E89	2.5L Petrol	Man	05-09		BMW16241	166						
Z4	E89	3.0L Petrol	Auto	05-09		BMW16251	166	BMW16271	166				
Z4	E89	3.0L Petrol	Man	05-09		BMW16241	166						
Z4	E89	3.0L Turbo Petrol	Man	05-09		BMW16241	166	BMW16271	166				
CHRYSLER													
300C		5.7L Petrol	Auto	01-09	12-09	CHR31150	177			CNX828			

MODEL	SERIES	ENGINE	TRANS	YEAR FROM	YEAR TO	RADIATOR OPTION 1	PAGE	RADIATOR OPTION 2	PAGE	CONDENSER OPTION 1	CONDENSER OPTION 2	RECEIVER DRIER OPTION 1	RECEIVER DRIER OPTION 2
300C	CRD LE	3.0L Turbo Diesel	Auto	06-06		CHR31150	177			CNX828			
300C	HEMILE	5.7L Petrol	Auto	11-05	07-09	CHR31150	177			CNX828			
300C	LE	3.5L Petrol	Auto	11-05		CHR31150	177			CNX828			
300C	SRT8	6.1L Petrol	Auto	12-06	02-09	CHR31150	177			CNX828			
300C	SRT8 LE	6.1L Petrol	Auto	04-06		CHR31150	177			CNX828			
GRAND VOYAGER	RG	2.8L Turbo Diesel	Auto	03-08		CHR1111	177			CNX656			
GRAND VOYAGER	RG	3.3L Petrol	Auto	06-01	03-08	CHR1111	177			CNX656			
GRAND VOYAGER	RG	3.8L Petrol	Auto	03-08		CHR1111	177			CNX656			
NEON		2.0L Petrol	Auto	08-96	09-99	J54CA	177			CNX650		RDx903	
NEON		2.0L Petrol	Man	08-96	09-99	J54CA	177			CNX650		RDx903	
NEON	SE	1.8L Petrol	Man	01-98	12-98	J54CA	177						
PT CRUISER		2.0L Petrol	Auto	07-00	11-04	CHR31145	178			CNX652		RDx935	
PT CRUISER		2.0L Petrol	Man	07-00	11-04	CHR31145	178			CNX652		RDx935	
PT CRUISER	CLASSIC	2.4L Petrol	Auto	11-04	05-08	CHR31145	178					RDx935	
PT CRUISER	CLASSIC	2.4L Petrol	Man	11-04	05-08	CHR31145	178					RDx935	
PT CRUISER	GRAND TOURER	2.4L Petrol	Auto	11-04		CHR31145	178					RDx935	
PT CRUISER	GRAND TOURER	2.4L Petrol	Man	11-04		CHR31145	178					RDx935	
PT CRUISER	LIMITED	2.4L Petrol	Auto	11-04	12-06	CHR31145	178					RDx935	
PT CRUISER	LIMITED	2.4L Petrol	Man	11-04	12-06	CHR31145	178					RDx935	
PT CRUISER	PG	2.4L Petrol	Man	01-05	12-06	CHR31145	178						
PT CRUISER	ROUTE	2.4L Petrol	Auto	12-05	02-07	CHR31145	178					RDx935	
PT CRUISER	TOURING	2.4L Petrol	Auto	06-06		CHR31145	178					RDx935	
PT CRUISER	TOURING	2.4L Petrol	Man	06-06		CHR31145	178					RDx935	
VOYAGER	GS	3.3L Petrol	Auto	02-97	06-02	CHR31140	178					RDx906	
VOYAGER	RG	3.3L Petrol	Auto	06-01	03-08	CHR1111	177	CHR1112	178	CNX653			

MODEL	SERIES	ENGINE	TRANS	YEAR FROM	YEAR TO	RADIATOR OPTION 1	PAGE	RADIATOR OPTION 2	PAGE	CONDENSER OPTION 1	CONDENSER OPTION 2	RECEIVER DRIER OPTION 1	RECEIVER DRIER OPTION 2
CITROEN													
BERLINGO	1.4L	1.4L Petrol	Man	07-99		CIT19511	178			CNX912			RDX245
XSARA		1.6L Petrol	Man	02-01	03-06	PEU10261	178						RDX6333
XSARA	VTR	1.6L Petrol	Man	02-01	03-06	PEU10261	178						RDX6333
DAEWOO													
CIELO	GL	1.5L Petrol	Auto	09-95	06-98	DAE0001	179			CNX151			RDX453
CIELO	GL	1.5L Petrol	Man	09-95	06-98	DAE0001	179	DAE1001	179	CNX151			RDX453
CIELO	GLX	1.5L Petrol	Auto	09-95	06-98	DAE0001	179			CNX151			RDX453
CIELO	GLX	1.5L Petrol	Man	09-95	06-98	DAE0001	179	DAE1001	179	CNX151			RDX453
CIELO	LOAD RUNNER	1.5L Petrol	Auto	07-96	06-98	DAE0001	179			CNX151			RDX453
CIELO	LOAD RUNNER	1.5L Petrol	Man	07-96	06-98	DAE0001	179	DAE1001	179	CNX151			RDX453
ESPERO	19W	2.0L Petrol	Auto	03-95	08-97	DAE0002	179						RDX453
ESPERO	19W	2.0L Petrol	Man	03-95	08-97	DAE1002	179						RDX453
KALOS	T200	1.5L Petrol	Auto	04-03	01-05	DAE0003	179			CNX158			
KALOS	T200	1.5L Petrol	Man	04-03	05-05	DAE0003	179	DAE1009	179	CNX158			
LACETTI	J200	1.8L Petrol	Auto	09-03	01-05	DAE0004	180						RDX164
LACETTI	J200	1.8L Petrol	Man	09-03	01-05	DAE1004	180						RDX164
LANOS	696	1.6L Petrol	Auto	08-97	11-99	DAE0005	180			CNX154			RDX451
LANOS	086E	1.6L Petrol	Auto	02-98	04-03	DAE0005	180			CNX154			RDX451
LANOS	086E	1.6L Petrol	Man	08-97	04-03	DAE1005	180			CNX154			RDX451
LANOS	08Y	1.5L Petrol	Auto	06-97	09-03	DAE0005	180			CNX154			RDX451
LANOS	08Y	1.5L Petrol	Man	08-97	09-03	DAE1005	180			CNX154			RDX451
LANOS	48Y	1.5L Petrol	Auto	08-97	09-02	DAE0005	180			CNX154			RDX451
LANOS	48Y	1.5L Petrol	Man	08-97	09-02	DAE1005	180			CNX154			RDX451

MODEL	SERIES	ENGINE	TRANS	YEAR FROM	YEAR TO	RADIATOR OPTION 1	PAGE	RADIATOR OPTION 2	PAGE	CONDENSER OPTION 1	CONDENSER OPTION 2	RECEIVER DRIER OPTION 1	RECEIVER DRIER OPTION 2
LANOS	696E	1.6L Petrol	Man	08-97	11-99	DAE1005	180		180	CNX154		RD451	
LANOS	69Y	1.5L Petrol	Auto	08-97	09-02	DAE0005	180		180	CNX154		RD451	
LANOS	69Y	1.5L Petrol	Man	08-97	09-02	DAE1005	180		180	CNX154		RD451	
LEGANZA	692E	2.2L Petrol	Auto	04-99	01-05	DAE0006	180		180	CNX153		RD452	
LEGANZA	692E	2.2L Petrol	Man	04-99	01-05	DAE0006	180	DAE1006	180	CNX153		RD452	
LEGANZA	692E	2.0L Petrol	Auto	08-97	04-00	DAE0006	180		180	CNX153		RD452	
LEGANZA	692E	2.0L Petrol	Man	08-97	04-00	DAE0006	180	DAE1006	180	CNX153		RD452	
MATIZ	11BE	.8L Petrol	Man	10-99	01-05	DAE1007	181		181	CNX213		RD162	
MATIZ	11BT	.8L Petrol	Auto	07-02	01-05	DAE0007	181		181	CNX157		RD162	
MATIZ	11BT	.8L Petrol	Man	11-00	07-02	DAE1007	181		181	CNX213		RD162	
MUSSO	B1D	2.9L Turbo Diesel	Auto	08-98	04-03	SSM0001	337			CNX865		RD476	
NUBIRA	356E	1.6L Petrol	Auto	07-97	10-99	DAE0008	181		181	CNX155		RD452	
NUBIRA	356E	1.6L Petrol	Man	07-97	10-99	DAE1006	180	DAE1008	181	CNX155		RD452	
NUBIRA	35ZE	2.0L Petrol	Auto	04-98	12-05	DAE0006	180	DAE0008	181	CNX155		RD452	
NUBIRA	35ZE	2.0L Petrol	Man	04-98	12-05	DAE1006	180	DAE1008	181	CNX155		RD452	
NUBIRA	486E	1.6L Petrol	Auto	04-98	10-99	DAE0008	181		181	CNX155		RD452	
NUBIRA	486E	1.6L Petrol	Man	04-98	10-99	DAE1006	180	DAE1008	181	CNX155		RD452	
NUBIRA	696E	1.6L Petrol	Auto	07-97	10-99	DAE0008	181		181	CNX155		RD452	
NUBIRA	696E	1.6L Petrol	Man	07-97	10-99	DAE1006	180	DAE1008	181	CNX155		RD452	
NUBIRA	692E	2.0L Petrol	Auto	04-98	12-05	DAE0006	180	DAE0008	181	CNX155		RD452	
NUBIRA	692E	2.0L Petrol	Man	04-98	12-05	DAE1006	180	DAE1008	181	CNX155		RD452	
TACUMA	75ZE	2.0L Petrol	Auto	10-00	01-05	DAE0004	180		180			RD7302	
TACUMA	75ZE	2.0L Petrol	Man	10-00	01-05	DAE1004	180		180			RD7302	
TACUMA	LE	2.0L Petrol	Auto	01-00	12-04	DAE0004	180		180				
TACUMA	LE	2.0L Petrol	Man	01-00	12-04	DAE1004	180		180				

MODEL	SERIES	ENGINE	TRANS	YEAR FROM	YEAR TO	RADIATOR OPTION 1	PAGE	RADIATOR OPTION 2	PAGE	CONDENSER OPTION 1	CONDENSER OPTION 2	RECEIVER DRIER OPTION 1	RECEIVER DRIER OPTION 2
DAF													
FTT2800		11.6L Turbo Diesel	Man	01-87	01-91	DAF21511	182						
FTT3300		11.6L Turbo Diesel	Man	01-87	01-91	DAF21511	182						
FTT3326		11.6L Turbo Diesel	Man	01-87	01-91	DAF21511	182						
FTT3600		11.6L Turbo Diesel	Man	01-87	01-91	DAF21511	182						
FTT3626		11.6L Diesel	Man	01-87	12-88	DAF21511	182						
DAIHATSU													
APPLAUSE	A101	1.6L Petrol	Auto	10-89	01-00	DAI1250	182			CNX9060			RDX282
APPLAUSE	A101	1.6L Petrol	Man	10-89	01-00	L4CM	182	L5CM	182	CNX9060			RDX282
CHARADE	G10	1.0L Petrol	Man	04-80	02-84	DAI14050	185						RDX086
CHARADE	G100	1.0L Petrol	Auto	01-87	05-93	L15CA	184	DAI1253	184				RDX161
CHARADE	G100	1.0L Petrol	Man	01-87	12-93	L13CM	185	DAI1191	184				RDX161
CHARADE	G102	1.3L Petrol	Auto	06-87	07-93	L21CA	184	DAI1253	184				RDX281
CHARADE	G11	1.0L Petrol	Auto	04-83	05-88	DAI14052	185						RDX086
CHARADE	G11	1.0L Petrol	Man	04-83	05-88	DAI14052	185						RDX086
CHARADE	G200	1.3L Petrol	Auto	05-93	12-97	DAI1178	184			CNX0860			RDX281
CHARADE	G200	1.3L Petrol	Man	05-93	12-97	L9CM	184			CNX0860			RDX281
CHARADE	G200	1.5L Petrol	Man	10-96	01-98	L4CM	182	L5CM	182				
CHARADE	G202	1.0L Petrol	Man	08-93	04-98	L4CM	182	L9CM	184				RDX281
CHARADE	G203	1.5L Petrol	Auto	08-94	04-98	DAI1178	184			CNX0860			RDX281
CHARADE	G203	1.5L Petrol	Man	01-94	01-00	L4CM	182	L5CM	182	CNX0860			RDX281
CHARADE	L251S	1.0L Petrol	Auto	07-03	03-06	L40CA	183			CNX8140			RDX0040
CHARADE	L251S	1.0L Petrol	Man	07-03	03-06	L40CM	183			CNX8140			RDX0040
CHARADE CENTRO	L500	.7L Petrol	Man	03-95	06-98	L39CM	183						RDX604

MODEL	SERIES	ENGINE	TRANS	YEAR FROM	YEAR TO	RADIATOR OPTION 1	PAGE	RADIATOR OPTION 2	PAGE	CONDENSER OPTION 1	CONDENSER OPTION 2	RECEIVER DRIER OPTION 1	RECEIVER DRIER OPTION 2
MIRA	L200V	.7L Petrol	Man	01-93	12-95	DAI1199	185		185			RDX282	
MIRA	L201	.8L Petrol	Man	10-90	10-92	DAI1199	185		185			RDX282	
MIRA J	L200	.7L Petrol	Man	04-92	03-96	DAI1199	185		185			RDX282	
MOVE	L601	.8L Petrol	Man	02-97	01-00	L39CM	183		183			RDX604	
PYZAR	G301	1.6L Petrol	Auto	02-97	08-00	DAI1178	184		184			RDX281	
PYZAR	G301	1.6L Petrol	Man	02-97	08-00	L4CM	182	L5CM	182			RDX281	
PYZAR	G303	1.5L Petrol	Auto	02-97	03-99	DAI1178	184		184			RDX281	
PYZAR	G303	1.5L Petrol	Man	02-97	03-99	L4CM	182	L5CM	182			RDX281	
SIRION	M100	1.0L Petrol	Auto	06-98	02-06	L38CA	186		186	CNX5580		RDX0040	
SIRION	M100	1.0L Petrol	Man	06-98	02-06	L36CM	186		186	CNX5580		RDX0040	
SIRION	M100	1.3L Petrol	Auto	09-00	04-02	L38CA	186		186				
SIRION	M100	1.3L Petrol	Man	09-00	04-02	L36CM	186		186				
SIRION	M101	1.3L Petrol	Auto	01-00	02-06	L38CA	186		186	CNX6200		RDX0040	
SIRION	M101	1.3L Petrol	Man	01-00	02-06	L36CM	186		186	CNX6200		RDX0040	
TERIOS	J100	1.3L Petrol	Auto	06-97	11-00	DAI14080	186		186	CNX8260		RDX281	
TERIOS	J100	1.3L Petrol	Man	06-97	11-00	DAI14082	186		186	CNX8260		RDX281	
TERIOS	J102	1.3L Petrol	Auto	10-00	12-05	DAI14080	186		186	CNX0870		RDX0040	
TERIOS	J102	1.3L Petrol	Man	10-00	12-05	DAI14082	186		186	CNX0870		RDX0040	
YRV	M201	1.3L Petrol	Auto	07-01	12-04	L38CA	186		186			RDX0040	
YRV	M201	1.3L Petrol	Man	07-01	12-04	L36CM	186		186			RDX0040	
DATSUN													
120Y	B210	1.2L Petrol	Auto	03-74	05-80	NIS46000		NIS46002	187				
120Y	B210	1.2L Petrol	Man	03-74	05-80	NIS46000		NIS46002	187				

MODEL	SERIES	ENGINE	TRANS	YEAR FROM	YEAR TO	RADIATOR OPTION 1	PAGE	RADIATOR OPTION 2	PAGE	CONDENSER OPTION 1	CONDENSER OPTION 2	RECEIVER DRIER OPTION 1	RECEIVER DRIER OPTION 2
FIAT													
DUCATO		2.8L Turbo Diesel	Man	01-02	02-08	FIA17281	188			CNX915			
DUCATO		3.0L Turbo Diesel	Man	02-07		FIA45111	188						
FORD													
BRONCO		4.1L Petrol	Auto	03-81	12-84	FOR003CA	188						
BRONCO		4.1L Petrol	Man	03-81	09-85	FOR003CA	188						
BRONCO		4.9L Petrol	Auto	01-86	01-87	FOR003CA	188						
BRONCO		4.9L Petrol	Auto	09-85	12-87	FOR003CA	188						
BRONCO		4.9L Petrol	Man	09-85	12-87	FOR003CA	188						
BRONCO		5.8L Petrol	Auto	03-81	09-85	FOR003CA	188						
BRONCO		5.8L Petrol	Man	03-81	09-85	FOR003CA	188						
CORSAIR	UA	2.0L Petrol	Auto	11-89	12-92	NIS40035	188					RD>X033	
CORSAIR	UA	2.0L Petrol	Man	11-89	12-92	NIS40035	188					RD>X033	
CORSAIR	UA	2.4L Petrol	Auto	11-89	12-92	NIS40035	188					RD>X033	
CORSAIR	UA	2.4L Petrol	Man	11-89	12-92	NIS40035	188					RD>X033	
COURIER		2.5L Turbo Diesel	Auto	12-99	12-06	FOR40315	189						
COURIER	B2000	2.0L Petrol	Man	11-82	05-86	MAZ40430	190					RD>X022	
COURIER	B2200	2.2L Petrol	Man	01-89	06-93	MAZ40350	190	MAZ40430	190			RD>X022	
COURIER	B2200	2.2L Diesel	Man	04-81	05-86	MAZ40430	190					RD>X022	
COURIER	PC	2.0L Petrol	Man	06-85	02-92	MAZ40350	190					RD>X022	
COURIER	PC	2.2L Diesel	Man	01-88	05-96	MAZ40350	190	MAZ40430	190	CNX019		RD>X022	
COURIER	PC	2.2L Petrol	Man	01-92	01-94	MAZ40350	190						
COURIER	PC	2.6L Petrol	Man	01-88	05-96	MAZ40350	190	FOR43022	190	CNX2860		RD>X022	
COURIER	PD	2.5L Diesel	Man	05-96	02-00	MAZ40350	190	FOR40319	189	CNX3000		RD>X022	

MODEL	SERIES	ENGINE	TRANS	YEAR FROM	YEAR TO	RADIATOR OPTION 1	PAGE	RADIATOR OPTION 2	PAGE	CONDENSER OPTION 1	CONDENSER OPTION 2	RECEIVER DRIER OPTION 1	RECEIVER DRIER OPTION 2
COURIER	PD	2.6L Petrol	Auto	05-96	02-00	FOR40315	189	FOR40318	188	CNX008		RDX022	
COURIER	PD	2.6L Petrol	Man	05-96	02-00	FOR40316	189	FOR40319	189	CNX008		RDX022	
COURIER	PE	2.5L Diesel	Man	02-99	11-02	FOR40316	189	FOR40319	189			RDX608	
COURIER	PE	2.5L Turbo Diesel	Man	02-99	11-02	FOR40316	189	FOR40319	189			RDX608	
COURIER	PE	2.6L Petrol	Auto	02-99	11-02	FOR40315	189	FOR40318	188	CNX008		RDX022	
COURIER	PE	2.6L Petrol	Man	02-99	11-02	FOR40316	189	FOR40319	189	CNX008		RDX022	
COURIER	PG	2.5L Diesel	Man	11-02	08-04	FOR40316	189	FOR40319	189	CNX400	CNX409	RDX191	
COURIER	PG	2.5L Turbo Diesel	Man	11-02	08-04	FOR40316	189	FOR40319	189	CNX400		RDX0050	RDX191
COURIER	PG	2.6L Petrol	Auto	11-02	08-04	FOR40315	189	FOR40318	188	CNX400	CNX409	RDX0050	RDX191
COURIER	PG	2.6L Petrol	Man	11-02	12-04	FOR40316	189	FOR40319	189	CNX400	CNX409	RDX0050	RDX191
COURIER	PH	2.5L Turbo Diesel	Auto	12-05	11-06	FOR40315	189	FOR40318	188				
COURIER	PH	2.5L Diesel	Man	08-04		FOR40316	189	FOR40319	189	CNX400	CNX409	RDX0050	RDX191
COURIER	PH	2.5L Turbo Diesel	Man	08-04	11-06	FOR40316	189	FOR40319	189	CNX400	CNX409	RDX0050	RDX191
COURIER	PH	2.6L Petrol	Auto	08-04	01-06	FOR40315	189	FOR40318	188				
COURIER	PH	2.6L Petrol	Man	08-04	01-06	FOR40316	189	FOR40319	189	CNX400	CNX409	RDX0050	RDX191
COURIER	PH	4.0L Petrol	Auto	01-05	11-06	FOR40315	189	FOR40318	188			RDX476	
COURIER	PH	4.0L Petrol	Man	01-05	11-06	FOR40316	189	FOR40319	189	CNX400	CNX409	RDX0050	RDX191
ECONOVAN	E1400	1.4L Petrol	Man	03-84	12-85	MAZ40420	191						
ECONOVAN	E1600	1.6L Petrol	Man	06-79	04-85	MAZ40420	191						
ECONOVAN	E1800	1.8L Petrol	Man	10-85	02-98	M43CM	190	FOR40210	191	CNX401			
ECONOVAN	E1800	2.0L Petrol		04-84	01-88	FOR40210	191						
ECONOVAN	E2000	2.0L Petrol	Man	10-85	04-97	FOR40210	191			CNX401			
ECONOVAN	E2000 JG	2.0L Petrol	Auto	02-97	01-00	M40CA	191						
ECONOVAN	E2000 JG	2.0L Petrol	Man	02-97	01-00	M40CM	191	FOR40210	191				
ECONOVAN	E2000 JH	2.0L Petrol	Man	10-99	01-03	M40CM	191	M43CM	190				
ECONOVAN	E2200	2.2L Diesel	Man	07-81	04-97	FOR40200	191						

MODEL	SERIES	ENGINE	TRANS	YEAR FROM	YEAR TO	RADIATOR OPTION 1	PAGE	RADIATOR OPTION 2	PAGE	CONDENSER OPTION 1	CONDENSER OPTION 2	RECEIVER DRIER OPTION 1	RECEIVER DRIER OPTION 2
FORD (continued)													
ESCAPE	BA	3.0L Petrol	Auto	03-01	04-04	MAZ1866	192			CNX115			RDX183
ESCAPE	XLT	3.0L Petrol	Auto	01-01	01-00	MAZ1866	192						
ESCAPE	ZA	3.0L Petrol	Auto	04-03	02-04	MAZ1866	192			CNX115			RDX183
ESCAPE	ZB	2.3L Petrol	Auto	02-04	06-06	MAZ1867	192		192				RDX183
ESCAPE	ZB	3.0L Petrol	Auto	02-04	06-06	MAZ1866	192			CNX115			RDX183
ESCAPE	ZC	2.3L Petrol	Auto	06-06	04-09	MAZ1867	192		192				
ESCAPE	ZC	3.0L Petrol	Auto	06-06	04-09	MAZ1866	192			CNX115			RDX183
ESCAPE	ZD	2.3L Petrol	Auto	04-08		MAZ1867	192						
EXPLORER	UN	4.0L Petrol	Auto	11-96	01-98	FOR1824	192						
EXPLORER	UN	4.0L Petrol	Man	11-96	11-97	FOR1824	192			CNX763			RDX755
EXPLORER	UP	4.0L Petrol	Auto	11-96	01-00	FOR1824	192			CNX763			RDX755
EXPLORER	UP	4.0L Petrol	Man	11-96	01-00	FOR1824	192			CNX763			RDX755
EXPLORER	UQ	4.0L Petrol	Auto	11-96	01-00	FOR1824	192						
EXPLORER	UQ	4.0L Petrol	Man	11-96	01-00	FOR1824	192						
EXPLORER	US	4.0L Petrol	Auto	10-96	10-01	FOR1824	192	FOR1949	192				RDX755
EXPLORER	US	4.0L Petrol	Man	10-96	10-01	FOR1824	192						RDX755
EXPLORER	UT	4.0L Petrol	Auto	10-01	02-03	FOR1949	192						
EXPLORER	UT	4.0L Petrol	Man	10-01	02-03	FOR1949	192						RDX755
EXPLORER	UT	4.6L Petrol	Auto	10-01	02-03	FOR1949	192						
EXPLORER	UX	4.0L Petrol	Auto	02-03	12-03	FOR1949	192			CNX744			
EXPLORER	UX	4.6L Petrol	Auto	02-03	12-03	FOR1949	192			CNX744			
EXPLORER	UZ	4.0L Petrol	Auto	12-03	01-08	FOR1949	192			CNX744			
EXPLORER	UZ	4.6L Petrol	Auto	12-03	01-08	FOR1949	192			CNX744			
F250		4.2L Turbo Diesel	Man	07-01	09-03	FOR1971	192			CNX768			RDX755

MODEL	SERIES	ENGINE	TRANS	YEAR FROM	YEAR TO	RADIATOR OPTION 1	PAGE	RADIATOR OPTION 2	PAGE	CONDENSER OPTION 1	CONDENSER OPTION 2	RECEIVER DRIER OPTION 1	RECEIVER DRIER OPTION 2
F250		5.4L Petrol	Auto	07-01	06-08	FOR1971	192		192	CNX768		RDX755	
F250		5.4L Petrol	Man	07-01	04-04	FOR1971	192		192	CNX768		RDX755	
F250		7.3L Turbo Diesel	Auto	07-01	10-06	FOR1971	192		192	CNX768		RDX755	
F250		7.3L Turbo Diesel	Man	07-01	10-06	FOR1971	192		192	CNX768		RDX755	
F350		7.3L Turbo Diesel	Auto	07-01	10-06	FOR1971	192		192	CNX768		RDX755	
F350		7.3L Turbo Diesel	Man	01-01	10-06	FOR1971	192		192	CNX768		RDX755	
F350	XL	5.4L Petrol	Man	07-01	09-03	FOR1971	192		192				
F350	XL	7.3L Turbo Diesel	Man	07-01	04-04	FOR1971	192		192	CNX768		RDX755	
FAIRLANE	AU	4.0L Petrol	Auto	02-99	04-00	FOR43283	196		196	CNX009		RDX093	
FAIRLANE	AU	4.0L Petrol	Auto	03-02	12-02	FOR43283	196		196	CNX009		RDX093	
FAIRLANE	AU	5.6L Petrol	Auto	01-02	01-03	FOR43283	196		196	CNX009		RDX093	
FAIRLANE	BA	4.0L Petrol	Auto	07-03	03-06	FOR43295	195	FOR00610	194	CNX6770	CNX677	RDX759	
FAIRLANE	BA	5.4L Petrol	Auto	03-05	10-05	FOR43295	195	FOR00610	194	CNX6770	CNX677	RDX759	
FAIRLANE	BF	4.0L Petrol	Auto	09-05	03-08	M45CM	195	FOR43292	194	CNX6770	CNX677	RDX759	
FAIRLANE	BF	4.0L Petrol	Man	10-05	12-06	M45CM	195	FOR43297	194	CNX6770	CNX677	RDX759	
FAIRLANE	BF	5.4L Petrol	Auto	09-05	03-08	M44CA	195	FOR43295	195	CNX6770	CNX677	RDX759	
FAIRLANE	BF	5.4L Petrol	Man	10-05	12-06	M46CA	194	FOR43297	194	CNX6770	CNX677	RDX759	
FAIRLANE	NA	3.9L Petrol	Auto	06-88	08-91	FOR43232	197	FOR43234	197	CNX001		RDX084	
FAIRLANE	NB	3.9L Petrol	Auto	08-91	04-92	FOR43232	197	FOR43234	197	CNX001		RDX084	
FAIRLANE	NB	4.0L Petrol	Auto	04-92	08-93	FOR43232	197	FOR43234	197				
FAIRLANE	NB	4.9L Petrol	Auto	04-92	08-93	FOR43232	197	FOR43234	197				
FAIRLANE	NB	4.9L Petrol	Auto	06-91	04-92	FOR43232	197	FOR43234	197				
FAIRLANE	NC	3.9L Petrol	Auto	07-91	04-93	FOR43232	197	FOR43234	197	CNX001		RDX084	
FAIRLANE	NC	4.0L Petrol	Auto	01-92	03-95	FOR43232	197	FOR43234	197	CNX001		RDX084	
FAIRLANE	NC	4.9L Petrol	Auto	01-91	03-95	FOR43232	197	FOR43234	197	CNX001		RDX084	

MODEL	SERIES	ENGINE	TRANS	YEAR FROM	YEAR TO	RADIATOR OPTION 1	PAGE	RADIATOR OPTION 2	PAGE	CONDENSER OPTION 1	CONDENSER OPTION 2	RECEIVER DRIER OPTION 1	RECEIVER DRIER OPTION 2
FORD (continued)													
FAIRLANE	NF	4.0L Petrol	Auto	03-95	09-96	FOR43258	197	FOR43260	196	CNX003		RDY085	
FAIRLANE	NF	4.9L Petrol	Auto	03-95	09-96	FOR43258	197	FOR43260	196	CNX002		RDY085	
FAIRLANE	NL	4.0L Petrol	Auto	09-96	02-99	FOR43258	197	FOR43260	196	CNX003		RDY800	
FAIRLANE	NL	4.9L Petrol	Auto	09-96	02-99	FOR43258	197	FOR43260	196	CNX003		RDY800	
FAIRLANE	ZA	3.3L Petrol	Auto	01-67	03-68	FOR43232	197	FOR43234	197				
FAIRLANE	ZB	3.6L Petrol	Man	03-68	07-69	FOR43232	197	FOR43234	197				
FAIRLANE	ZC	4.9L Petrol	Auto	07-69	11-70	FOR43232	197	FOR43234	197				
FAIRLANE	ZC	5.8L Petrol	Auto	07-69	11-70	FOR43232	197	FOR43234	197				
FAIRLANE	ZH	4.9L Petrol	Auto	05-76	04-80	FD9288CA	198	FD9288CA	198				
FAIRLANE	ZH	5.8L Petrol	Auto	05-76	04-80	FD9288CA	198	FD9288CA	198				
FAIRLANE	ZJ	4.1L Petrol	Auto	10-79	03-83	FD9288CA	198	FD9288CA	198			RDY080	RDY081
FAIRLANE	ZJ	4.9L Petrol	Auto	05-79	03-83	FD9288CA	198	FD9288CA	198				
FAIRLANE	ZJ	5.8L Petrol	Auto	05-79	03-83	FD9288CA	198	FD9288CA	198				
FAIRLANE	ZK	4.1L Petrol	Auto	03-82	10-84	FD9288CA	198	FD9288CA	198			RDY080	
FAIRLANE	ZK	4.9L Petrol	Auto	03-82	10-84	FD9288CA	198	FD9288CA	198				
FAIRLANE	ZK	5.8L Petrol	Auto	03-82	10-84	FD9288CA	198	FD9288CA	198				
FAIRLANE	ZL	4.1L Petrol	Auto	10-84	06-89	FD9288CA	198	FD9288CA	198	CNX005		RDY083	
FAIRMONT	AU	4.0L Petrol	Auto	04-00	11-01	FOR43283	196			CNX009		RDY093	
FAIRMONT	AU	4.0L Petrol	Auto	09-98	04-00	FOR43283	196			CNX009		RDY093	
FAIRMONT	BA	4.0L Petrol	Auto	09-02	10-04	FOR43295	195	FOR00610	194	CNX6770	CNX677	RDY759	
FAIRMONT	BA	5.4L Petrol	Auto	10-04	10-05	FOR43295	195	FOR00610	194	CNX6770	CNX677	RDY759	
FAIRMONT	BF	4.0L LPG	Auto	10-06	04-09	FOR43292	194	FOR09591	194	CNX6770	CNX677	RDY759	
FAIRMONT	BF	4.0L Petrol	Auto	10-06	04-09	FOR43292	194	FOR09591	194	CNX6770	CNX677	RDY759	
FAIRMONT	BF	5.4L Petrol	Auto	10-06	04-09	M44CA	195	FOR43295	195	CNX6770	CNX677	RDY759	
FAIRMONT	EA	3.9L Petrol	Auto	02-88	11-89	FOR43232	197	FOR43234	197	CNX001		RDY084	

MODEL	SERIES	ENGINE	TRANS	YEAR FROM	YEAR TO	RADIATOR OPTION 1	PAGE	RADIATOR OPTION 2	PAGE	CONDENSER OPTION 1	CONDENSER OPTION 2	RECEIVER DRIER OPTION 1	RECEIVER DRIER OPTION 2
FAIRMONT	EA	3.9L Petrol	Man	02-88	11-89	FOR43232	197	FOR09591	194	CNX001		RD084	
FAIRMONT	EB	3.9L Petrol	Auto	07-91	04-92	FOR43232	197	FOR09591	194	CNX001		RD084	
FAIRMONT	EB	3.9L Petrol	Man	07-91	04-92	FOR43232	197	FOR09591	194	CNX001		RD084	
FAIRMONT	EB	4.0L Petrol	Auto	04-92	08-93	FOR43232	197	FOR09591	194	CNX001		RD084	
FAIRMONT	EB	4.9L Petrol	Auto	07-91	04-92	FOR43232	197	FOR09591	194	CNX001		RD084	
FAIRMONT	EB	4.9L Petrol	Man	01-92	12-92	FOR43232	197	FOR09591	194				
FAIRMONT	EB	4.9L Petrol	Man	07-91	04-92	FOR43232	197	FOR09591	194				
FAIRMONT	ED	4.0L Petrol	Auto	08-93	08-94	FOR43232	197	FOR09591	194	CNX001		RD085	
FAIRMONT	ED	4.9L Petrol	Auto	08-93	08-94	FOR43232	197	FOR09591	194	CNX001		RD085	
FAIRMONT	EF	4.0L Petrol	Auto	08-94	09-96	FOR43258	197	FOR43260	196	CNX002		RD085	
FAIRMONT	EF	4.9L Petrol	Auto	08-94	09-96	FOR43258	197	FOR43260	196	CNX002		RD085	
FAIRMONT	EL	4.0L Petrol	Auto	09-96	09-98	FOR43258	197	FOR43260	196	CNX003		RD085	
FAIRMONT	EL	4.9L Petrol	Auto	09-96	09-98	FOR43258	197	FOR43260	196	CNX003		RD085	
FAIRMONT	XC	4.1L Petrol	Auto	08-76	03-79	FD9288CA	198						
FAIRMONT	XC	4.1L Petrol	Man	08-76	03-79	FD9288CA	198						
FAIRMONT	XC	4.9L Petrol	Auto	08-76	03-79	FD9288CA	198						
FAIRMONT	XC	4.9L Petrol	Man	08-76	03-79	FD9288CA	198						
FAIRMONT	XC	5.8L Petrol	Auto	07-76	04-79	FD9288CA	198						
FAIRMONT	XC	5.8L Petrol	Man	07-76	04-79	FD9288CA	198						
FAIRMONT	XD	3.3L Petrol	Auto	07-80	03-82	FD9288CA	198					RD080	
FAIRMONT	XD	4.1L Petrol	Auto	03-79	03-82	FD9288CA	198						
FAIRMONT	XD	4.1L Petrol	Man	03-79	03-82	FD9288CA	198						
FAIRMONT	XD	4.9L Petrol	Auto	03-79	03-82	FD9288CA	198						
FAIRMONT	XD	4.9L Petrol	Man	03-79	03-82	FD9288CA	198						
FAIRMONT	XD	5.8L Petrol	Auto	03-79	03-82	FD9288CA	198						

MODEL	SERIES	ENGINE	TRANS	YEAR FROM	YEAR TO	RADIATOR OPTION 1	PAGE	RADIATOR OPTION 2	PAGE	CONDENSER OPTION 1	CONDENSER OPTION 2	RECEIVER DRIER OPTION 1	RECEIVER DRIER OPTION 2
FORD (continued)													
FAIRMONT	XD	5.8L Petrol	Man	03-79	01-82	FD9288CA	198						
FAIRMONT	XD	5.8L Petrol	Man	03-79	03-82	FD9288CA	198						
FAIRMONT	XE	3.3L Petrol	Auto	03-82	10-84	FD9288CA	198						
FAIRMONT	XE	3.3L Petrol	Man	03-82	10-84	FD9288CA	198						
FAIRMONT	XE	4.1L Petrol	Auto	03-82	10-84	FD9288CA	198						
FAIRMONT	XE	4.1L Petrol	Man	03-82	10-84	FD9288CA	198						
FAIRMONT	XE	4.9L Petrol	Auto	03-82	10-84	FD9288CA	198						
FAIRMONT	XE	5.0L Petrol	Man	01-82	12-82	FD9288CA	198						
FAIRMONT	XE	5.8L Petrol	Auto	01-82	12-82	FD9288CA	198						
FAIRMONT	XE	5.8L Petrol	Man	01-82	12-82	FD9288CA	198						
FAIRMONT	XE	5.8L Petrol	Man	03-82	10-84	FD9288CA	198						
FAIRMONT	XF	4.1L Petrol	Auto	01-84	02-88	FD9288CA	198			CNX005			RD X083
FAIRMONT	XF	4.1L Petrol	Man	01-84	02-88	FD9288CA	198			CNX005			RD X083
FALCON	AU	4.0L LPG	Auto	04-00	03-03	FOR43283	196			CNX009			RD X093
FALCON	AU	4.0L LPG	Man	04-00	01-03	FOR43283	196						
FALCON	AU	4.0L Petrol	Man	04-00	11-01	FOR43283	196			CNX009			RD X093
FALCON	AU	4.9L Petrol	Auto	06-99	04-00	FOR43283	196			CNX009			RD X093
FALCON	AU	4.9L Petrol	Man	04-00	03-03	FOR43283	196			CNX009			RD X093
FALCON	BA	4.0L LPG	Auto	01-02	10-04	FOR43295	195	FOR00610	194	CNX6770	CNX677		RD X759
FALCON	BA	4.0L Petrol	Auto	09-02	10-04	FOR43295	195	FOR00610	194	CNX6770	CNX677		RD X759
FALCON	BA	4.0L Turbo Petrol	Auto	09-02	10-04	FOR43295	195	FOR00610	194	CNX6770	CNX677		RD X759
FALCON	BA	4.0L Petrol	Man	05-04	10-05	FOR43232	197	FOR09591	194	CNX6770	CNX677		RD X759
FALCON	BA	4.0L Turbo Petrol	Man	09-02	10-04	FOR43232	197	FOR09591	194	CNX6770	CNX677		RD X759
FALCON	BA	4.0L LPG	Man	10-02	10-04	FOR43232	197	FOR09591	194	CNX6770	CNX677		RD X759

MODEL	SERIES	ENGINE	TRANS	YEAR FROM	YEAR TO	RADIATOR OPTION 1	PAGE	RADIATOR OPTION 2	PAGE	CONDENSER OPTION 1	CONDENSER OPTION 2	RECEIVER DRIER OPTION 1	RECEIVER DRIER OPTION 2
FALCON	BA	5.4L Petrol	Auto	03-03	10-04	FOR43295	195	FOR00610	194	CNX6770	CNX677	RDx759	
FALCON	BF	4.0L LPG	Auto	02-06	10-06	FOR43232	197	FOR09591	194	CNX6770	CNX677	RDx759	
FALCON	BF	4.0L LPG	Man	01-05	12-06	M45CM	195	FOR43292	194	CNX6770	CNX677	RDx759	
FALCON	BF	4.0L Petrol	Man	02-06	10-06	M45CM	195	FOR43292	194	CNX6770	CNX677	RDx759	
FALCON	BF	4.0L Turbo Petrol	Man	09-05	04-09	M45CM	195	FOR43292	194	CNX677	CNX6770	RDx759	
FALCON	BF	5.4L Petrol	Auto	05-06	10-06	FOR43292	194	FOR43295	195	CNX6770	CNX677	RDx759	
FALCON	BF	5.4L Petrol	Auto	10-06	04-09	FOR43292	194	FOR43295	195	CNX6770	CNX677	RDx759	
FALCON	BF	5.4L Petrol	Man	09-05	05-07	M44CM	195	FOR43292	194	CNX6770	CNX677	RDx759	
FALCON	EA	3.2L Petrol	Auto	02-88	01-90	FOR43232	197	FOR43234	197	CNX001		RDx084	
FALCON	EA	3.2L Petrol	Man	02-88	01-90	FOR43232	197	FOR43234	197	CNX001		RDx084	
FALCON	EA	3.9L Petrol	Auto	11-89	07-91	FOR43232	197	FOR43234	197	CNX001		RDx084	
FALCON	EA	3.9L Petrol	Man	02-88	11-89	FOR43232	197	FOR43234	197	CNX001		RDx084	
FALCON	EB	3.9L Petrol	Auto	07-91	04-92	FOR43232	197	FOR43234	197	CNX001		RDx084	
FALCON	EB	3.9L Petrol	Man	07-91	04-92	FOR43232	197	FOR43234	197	CNX001		RDx084	
FALCON	EB	4.0L Petrol	Auto	04-92	08-93	FOR43232	197	FOR43234	197	CNX001		RDx084	
FALCON	EB	4.0L Petrol	Man	04-92	08-93	FOR43232	197	FOR43234	197	CNX001		RDx084	
FALCON	EB	4.9L Petrol	Auto	07-91	08-93	FOR43232	197	FOR43234	197	CNX001		RDx084	
FALCON	EB	4.9L Petrol	Man	07-91	08-93	FOR43232	197	FOR43234	197	CNX001		RDx084	
FALCON	ED	4.0L Petrol	Auto	10-93	08-94	FOR43232	197	FOR43234	197	CNX001		RDx085	
FALCON	ED	4.0L Petrol	Man	10-93	08-94	FOR43232	197	FOR43234	197	CNX001		RDx085	
FALCON	ED	4.9L Petrol	Auto	08-93	08-94	FOR43232	197	FOR43234	197	CNX001		RDx085	
FALCON	ED	4.9L Petrol	Man	08-93	08-94	FOR43232	197	FOR43234	197	CNX001		RDx085	
FALCON	EF	4.0L Petrol	Auto	08-94	09-98	FOR43258	197	FOR43260	196	CNX003		RDx085	
FALCON	EF	4.0L Petrol	Man	08-94	09-96	FOR43258	197	FOR43260	196	CNX003		RDx085	
FALCON	EF	4.0L Petrol	Man	08-94	10-95	FOR43258	197	FOR43260	196	CNX003		RDx085	
FALCON	EF	4.9L Petrol	Auto	08-94	09-96	FOR43258	197	FOR43260	196	CNX002	CNX003	RDx085	

MODEL	SERIES	ENGINE	TRANS	YEAR FROM	YEAR TO	RADIATOR OPTION 1	PAGE	RADIATOR OPTION 2	PAGE	CONDENSER OPTION 1	CONDENSER OPTION 2	RECEIVER DRIER OPTION 1	RECEIVER DRIER OPTION 2
FORD (continued)													
FALCON	EF	4.9L Petrol	Man	08-94	09-96	FOR43258	197	FOR43260	196	CNX002	CNX003	RDY085	
FALCON	EL	4.0L Petrol	Auto	09-96	09-98	FOR43258	197	FOR43260	196	CNX003		RDY085	RDX800
FALCON	EL	4.0L Petrol	Man	09-96	09-98	FOR43258	197	FOR43260	196	CNX003		RDY085	RDX800
FALCON	EL	4.9L Petrol	Auto	09-96	09-98	FOR43258	197	FOR43260	196	CNX003		RDY085	RDX800
FALCON	EL	4.9L Petrol	Man	09-96	09-98	FOR43258	197	FOR43260	196	CNX003		RDY085	RDX800
FALCON	FG	4.0L LPG	Auto	04-08		M47CA	193	M48CM	193	CNX4260		RDY0360	
FALCON	FG	4.0L Petrol	Auto	04-08		M47CA	193	M48CM	193	CNX4260		RDY0360	
FALCON	FG	4.0L Turbo Petrol	Auto	04-08		M47CA	193	M48CM	193	CNX4260		RDY0360	
FALCON	FG	4.0L Petrol	Man	04-08		M47CA	193	M48CM	193	CNX4260		RDY0360	
FALCON	FG	4.0L Turbo Petrol	Man	04-08		M47CA	193	M48CM	193	CNX4260		RDY0360	
FALCON	FG	5.4L Petrol	Auto	04-08		M49CA	193			CNX4260		RDY0360	
FALCON	FG	5.4L Petrol	Man	04-08		M48CM	193			CNX4260		RDY0360	
FALCON	XC	3.3L Petrol	Auto	08-76	03-79	FD9288CA	198					RDY090	
FALCON	XC	3.3L Petrol	Man	01-77	01-80	FD9288CA	198					RDY090	
FALCON	XC	4.1L Petrol	Auto	08-76	10-79	FD9288CA	198					RDY090	
FALCON	XC	4.1L Petrol	Man	08-76	10-79	FD9288CA	198					RDY090	
FALCON	XC	4.9L Petrol	Auto	07-76	04-79	FD9288CA	198						
FALCON	XC	4.9L Petrol	Auto	08-76	10-79	FD9288CA	198					RDY090	
FALCON	XC	4.9L Petrol	Man	07-76	01-78	FD9288CA	198						
FALCON	XC	4.9L Petrol	Man	08-76	10-79	FD9288CA	198					RDY090	
FALCON	XC	5.0L Petrol	Auto	01-79	12-79	FD9288CA	198						
FALCON	XC	5.0L Petrol	Man	01-77	01-80	FD9288CA	198						
FALCON	XC	5.8L Petrol	Auto	08-76	10-79	FD9288CA	198					RDY090	
FALCON	XC	5.8L Petrol	Man	08-76	10-79	FD9288CA	198					RDY090	

MODEL	SERIES	ENGINE	TRANS	YEAR FROM	YEAR TO	RADIATOR OPTION 1	PAGE	RADIATOR OPTION 2	PAGE	CONDENSER OPTION 1	CONDENSER OPTION 2	RECEIVER DRIER OPTION 1	RECEIVER DRIER OPTION 2
FALCON	XD	3.3L Petrol	Auto	08-79	04-82	FD9288CA	198			CNX020		RDx080	
FALCON	XD	3.3L Petrol	Man	10-79	04-83	FD9288CA	198					RDx080	
FALCON	XD	4.1L Petrol	Auto	07-80	03-83	FD9288CA	198			CNX020		RDx080	
FALCON	XD	4.1L Petrol	Man	10-79	04-83	FD9288CA	198					RDx080	
FALCON	XD	4.9L Petrol	Auto	01-79	12-79	FD9288CA	198						
FALCON	XD	4.9L Petrol	Auto	10-79	04-83	FD9288CA	198					RDx080	
FALCON	XD	4.9L Petrol	Man	01-79	12-79	FD9288CA	198						
FALCON	XD	4.9L Petrol	Man	10-79	04-83	FD9288CA	198					RDx080	
FALCON	XD	5.0L Petrol	Auto	01-80	01-83	FD9288CA	198			CNX020		RDx081	
FALCON	XD	5.0L Petrol	Man	01-80	01-83	FD9288CA	198						
FALCON	XD	5.8L Petrol	Auto	03-79	07-81	FD9288CA	198					RDx080	
FALCON	XD	5.8L Petrol	Man	10-79	04-83	FD9288CA	198					RDx080	
FALCON	XE	3.3L Petrol	Auto	04-82	12-84	FD9288CA	198			CNX021		RDx081	
FALCON	XE	3.3L Petrol	Man	04-82	12-84	FD9288CA	198					RDx081	
FALCON	XE	4.1L Petrol	Auto	04-82	12-84	FD9288CA	198			CNX021		RDx081	
FALCON	XE	4.1L Petrol	Man	04-82	10-84	FD9288CA	198					RDx081	
FALCON	XE	4.9L Petrol	Auto	01-82	12-82	FD9288CA	198						
FALCON	XE	4.9L Petrol	Auto	03-82	10-84	FD9288CA	198					RDx081	
FALCON	XE	5.8L Petrol	Auto	01-82	12-82	FD9288CA	198						
FALCON	XE	5.8L Petrol	Man	03-82	12-82	FD9288CA	198					RDx081	
FALCON	XF	3.3L Petrol	Auto	01-84	12-90	FD9288CA	198			CNX005		RDx083	
FALCON	XF	3.3L Petrol	Man	10-84	12-90	FD9288CA	198			CNX005		RDx083	
FALCON	XF	4.1L Petrol	Auto	10-84	02-88	FD9288CA	198			CNX005		RDx083	
FALCON	XF	4.1L Petrol	Man	01-84	03-93	FD9288CA	198			CNX005		RDx083	
FALCON	XG	4.0L Petrol	Auto	03-93	04-97	FOR1207	198			CNX001		RDx083	

MODEL	SERIES	ENGINE	TRANS	YEAR FROM	YEAR TO	RADIATOR OPTION 1	PAGE	RADIATOR OPTION 2	PAGE	CONDENSER OPTION 1	CONDENSER OPTION 2	RECEIVER DRIER OPTION 1	RECEIVER DRIER OPTION 2
FORD (continued)													
FALCON	XG	4.0L Petrol	Man	03-93	04-97	FOR1207	198			CNX001			RDY083
FALCON	XH	4.0L Petrol	Auto	04-96	10-97	FOR43258	197	FOR43260	196	CNX003			RDY085
FALCON	XH	4.0L Petrol	Man	04-96	10-97	FOR43258	197	FOR43260	196	CNX003			RDY085
FALCON	XH	4.9L Petrol	Auto	10-97	01-00	FOR43258	197	FOR43260	196	CNX003			RDY800
FALCON	XH	4.9L Petrol	Man	10-97	01-00	FOR43258	197	FOR43260	196	CNX003			RDY800
FESTIVA	WA	1.3L Petrol	Auto	10-91	03-95	M36CA	199						RDY600
FESTIVA	WA	1.3L Petrol	Man	10-91	03-95	M36CM	199						RDY600
FESTIVA	WB	1.3L Petrol	Auto	03-94	02-97	M35CA	198	M36CA	199				RDY022
FESTIVA	WB	1.3L Petrol	Man	03-94	02-97	M34CM	198	M36CM	199				RDY022
FESTIVA	WB II (WD)	1.3L Petrol	Auto	02-97	12-97	M35CA	198	M36CA	199	CNX010			RDY283
FESTIVA	WB II (WD)	1.3L Petrol	Man	02-97	12-97	M34CM	198	M36CM	199	CNX010			RDY283
FESTIVA	WB II (WD)	1.5L Petrol	Auto	02-97	12-97	M35CA	198	M36CA	199	CNX010			RDY022
FESTIVA	WB II (WD)	1.5L Petrol	Man	02-97	12-97	M34CM	198	M36CM	199	CNX010			RDY022
FESTIVA	WF	1.3L Petrol	Auto	01-98	12-00	M35CA	198	G10CA	199	CNX754			RDY601
FESTIVA	WF	1.3L Petrol	Man	01-98	12-00	M34CM	198	G10CM	199	CNX754			RDY601
FESTIVA	WF	1.5L Petrol	Auto	01-98	12-00	M35CA	198	G10CA	199	CNX754			RDY601
FESTIVA	WF	1.5L Petrol	Man	01-98	12-00	M34CM	198	G10CM	199	CNX754			RDY601
FIESTA	WP	1.6L Petrol	Auto	02-04	01-06	FOR1879	199	FOR64311	200	CNX753			RDY185
FIESTA	WP	1.6L Petrol	Auto	02-04	01-06	FOR1879	199						
FIESTA	WP	1.6L Petrol	Man	02-04	01-06	FOR64311	200			CNX753			RDY185
FIESTA	WQ	1.6L Petrol	Auto	01-06	03-09	FOR1879	199			CNX753			RDY185
FIESTA	WQ	1.6L Petrol	Man	01-06	03-09	FOR1879	199	FOR64311	200	CNX753			RDY185
FIESTA	WQ XR4	2.0L Petrol	Man	06-07	03-09	FOR1879	199	FOR64311	200	CNX753			RDY185
FIESTA	WS	1.4L Petrol	Auto	02-09		FOR1879	199			CNX742			
FIESTA	WS	1.6L Petrol	Man	01-09		FOR1879	199	FOR54761	199	CNX742			

MODEL	SERIES	ENGINE	TRANS	YEAR FROM	YEAR TO	RADIATOR OPTION 1	PAGE	RADIATOR OPTION 2	PAGE	CONDENSER OPTION 1	CONDENSER OPTION 2	RECEIVER DRIER OPTION 1	RECEIVER DRIER OPTION 2
FIESTA	WT	1.6L Petrol	Auto	10-10		FOR1879	199						
FIESTA	WT	1.6L Petrol	Man	10-10		FOR1879	199	FOR54761	199				
FIESTA	WT	1.6L Turbo Diesel	Man	10-10		FOR1879	199	FOR54761	199				
FOCUS		1.6L Petrol	Auto	01-00	12-05	FOR64031	200						
FOCUS	LR	1.8L Petrol	Man	10-02	06-05	FOR20301	200	FOR64031	200	CNX762		RDX185	
FOCUS	LR	2.0L Petrol	Auto	09-02	04-05	FOR20301	200	FOR64031	200	CNX762		RDX185	
FOCUS	LR	2.0L Petrol	Auto	09-02	04-05	FOR20301	200	FOR64031	200	CNX762		RDX185	
FOCUS	LR	2.0L Petrol	Man	10-02	06-05	FOR20301	200	FOR64031	200	CNX762		RDX185	
FOCUS	LR	2.0L Petrol	Man	09-02	04-05	FOR20301	200	FOR64031	200	CNX762		RDX185	
FOCUS	LS	2.5L Turbo Petrol	Man	05-06	07-07	FOR40080	200	FOR64031	200	CNX774			
FOCUS	LT	2.5L Turbo Petrol	Man	07-07	03-09	FOR40080	200			CNX774			
LASER		1.6L Petrol	Auto	01-99	12-03	MAZ40142	200						
LASER	KA	1.3L Petrol	Man	03-81	02-84	MAZ40051	203					RDX086	
LASER	KA	1.5L Petrol	Man	03-81	02-84	MAZ40051	203					RDX086	
LASER	KB	1.3L Petrol	Man	03-83	01-86	MAZ40051	203					RDX086	
LASER	KB	1.5L Petrol	Man	01-85	01-86	MAZ40051	203					RDX086	
LASER	KB	1.5L Turbo Petrol	Man	06-85	10-85	MAZ40051	203						
LASER	KC	1.3L Petrol	Man	10-85	10-87	M13CM	202	FOR40100	203	CNX006		RDX086	
LASER	KC	1.3L Petrol	Man	10-85	10-87	FOR40100	203						
LASER	KC	1.3L Petrol	Man	10-85	10-87	FOR40100	203						
LASER	KC	1.6L Petrol	Auto	10-85	09-87	M14CA	203			CNX006		RDX086	
LASER	KC	1.6L Petrol	Man	10-85	10-87	M13CM	202			CNX006		RDX086	
LASER	KE	1.3L Petrol	Man	10-87	02-90	FOR40100	203			CNX006		RDX086	
LASER	KE	1.6L Petrol	Auto	10-87	10-90	FOR40053	202			CNX006		RDX086	
LASER	KE	1.6L Petrol	Man	10-87	02-91	FOR40051	202			CNX006		RDX086	

MODEL	SERIES	ENGINE	TRANS	YEAR FROM	YEAR TO	RADIATOR OPTION 1	PAGE	RADIATOR OPTION 2	PAGE	CONDENSER OPTION 1	CONDENSER OPTION 2	RECEIVER DRIER OPTION 1	RECEIVER DRIER OPTION 2
FORD (continued)													
LASER	KE	1.6L Turbo Petrol	Man	10-87	04-91	FOR40051	202			CNX006		RDX086	
LASER	KE2	1.6L Petrol	Auto	04-90	01-96	FOR40053	202						
LASER	KE2	1.6L Petrol	Man	04-90	01-96	FOR40051	202						
LASER	KF	1.6L Petrol	Auto	04-90	10-91	MAZ40050	202	FOR40059	202	CNX007		RDX180	
LASER	KF	1.6L Petrol	Man	04-90	10-91	FOR40055	202			CNX007		RDX180	
LASER	KF	1.8L Petrol	Auto	04-90	10-91	MAZ40050	202	FOR40059	202	CNX007		RDX180	
LASER	KF	1.8L Turbo Petrol	Man	04-90	01-92	FOR40057	201			CNX007		RDX180	
LASER	KF	1.8L Petrol	Man	04-90	10-91	FOR40055	202	FOR40057	201	CNX007		RDX180	
LASER	KH	1.6L Petrol	Auto	10-91	10-94	MAZ40050	202	FOR40059	202	CNX007		RDX180	
LASER	KH	1.6L Petrol	Man	10-91	10-94	FOR40055	202			CNX007		RDX180	
LASER	KH	1.8L Petrol	Auto	10-91	10-94	MAZ40050	202	FOR40059	202	CNX007		RDX180	
LASER	KH	1.8L Petrol	Man	11-91	01-94	FOR40057	201			CNX007		RDX180	
LASER	KJ	1.6L Petrol	Auto	10-94	12-96	FOR40065	201	FOR40120	201			RDX087	RDX182
LASER	KJ	1.6L Petrol	Man	10-94	12-96	M33CM	201	FOR40067	201			RDX087	RDX182
LASER	KJ	1.8L Petrol	Auto	10-94	12-96	FOR40065	201	FOR40120	201			RDX087	RDX182
LASER	KJ	1.8L Petrol	Man	10-94	12-96	M33CM	201	FOR40067	201			RDX087	RDX182
LASER	KN	1.6L Petrol	Auto	02-99	04-02	MAZ40142	200	FOR40065	201	CNX759		RDX182	
LASER	KN	1.6L Petrol	Man	02-99	04-02	M41CM	200	FOR40067	201	CNX759		RDX182	
LASER	KN	1.8L Petrol	Auto	02-99	04-02	MAZ40142	200	FOR40065	201	CNX759		RDX182	
LASER	KN	1.8L Petrol	Man	02-99	04-02	M41CM	200	FOR40067	201	CNX759		RDX182	
LASER	KQ	1.6L Petrol	Auto	04-01	10-02	MAZ40142	200	FOR40065	201	CNX759		RDX182	
LASER	KQ	1.6L Petrol	Man	04-01	10-02	MAZ40144	201	FOR40067	201	CNX759		RDX182	
LASER	KQ	1.8L Petrol	Auto	04-01	10-02	MAZ40142	200	FOR40065	201	CNX759		RDX182	

MODEL	SERIES	ENGINE	TRANS	YEAR FROM	YEAR TO	RADIATOR OPTION 1	PAGE	RADIATOR OPTION 2	PAGE	CONDENSER OPTION 1	CONDENSER OPTION 2	RECEIVER DRIER OPTION 1	RECEIVER DRIER OPTION 2
LASER	KQ	1.8L Petrol	Man	04-01	10-02	MAZ40144	201	FOR40067	201	CNX759		RDX182	
LASER	KQ	2.0L Petrol	Auto	04-01	10-02	MAZ40142	200	FOR40065	201	CNX759		RDX182	
LASER	KQ	2.0L Petrol	Man	04-01	10-02	MAZ40144	201	FOR40067	201	CNX759		RDX182	
LASER	LYNX	1.6L Petrol	Auto	01-92	12-97	FOR40120	201						
LASER	LYNX	1.6L Petrol	Auto	01-92	12-97	FOR40120	201						
LTD	AU	4.0L Petrol	Auto	06-00	07-03	FOR43281	196	FOR43283	196	CNX009		RDX093	
LTD	BA	5.4L Petrol	Auto	07-03	03-06	M44CA	195	FOR43295	195	CNX6770	CNX677	RDX759	
LTD	BF	5.4L Petrol	Auto	09-05	03-08	M44CA	195	FOR43295	195	CNX6770	CNX677	RDX759	
LTD	DA	3.9L Petrol	Auto	06-88	12-91	FOR43232	197	FOR43234	197			RDX084	
LTD	DB	3.9L Petrol	Auto	08-91	04-92	FOR43232	197	FOR43234	197			RDX084	
LTD	DB	4.0L Petrol	Auto	04-92	08-93	FOR43232	197	FOR43234	197	CNX001		RDX084	
LTD	DB	4.9L Petrol	Auto	04-92	08-93	FOR43232	197	FOR43234	197	CNX001		RDX084	
LTD	DC	4.0L Petrol	Auto	01-91	03-95	FOR43232	197	FOR43234	197	CNX001		RDX084	
LTD	DC	4.9L Petrol	Auto	01-91	03-95	FOR43232	197	FOR43234	197	CNX001		RDX084	
LTD	DF	4.0L Petrol	Auto	03-95	09-96	FOR43232	197	FOR43234	197	CNX003		RDX085	
LTD	DF	4.9L Petrol	Auto	03-95	09-96	FOR43232	197	FOR43234	197	CNX002		RDX085	
LTD	DL	4.0L Petrol	Auto	09-96	07-99	FOR43232	197	FOR43234	197	CNX003		RDX800	
LTD	DL	4.9L Petrol	Auto	09-96	07-99	FOR43232	197	FOR43234	197	CNX003		RDX800	
LTD	FC	4.1L Petrol	Auto	10-79	03-82	FOR43232	197	FOR43234	197			RDX080	
LTD	FC	4.9L Petrol	Auto	10-79	03-82	FOR43232	197	FOR43234	197			RDX080	
LTD	FC	5.8L Petrol	Auto	10-79	03-82	FOR43232	197	FOR43234	197			RDX080	
LTD	FD	4.1L Petrol	Auto	03-82	10-84	FOR43232	197	FOR43234	197			RDX082	
LTD	FD	4.9L Petrol	Auto	03-82	10-84	FOR43232	197	FOR43234	197			RDX081	
LTD	FD	5.8L Petrol	Auto	03-82	10-84	FOR43232	197	FOR43234	197			RDX081	
LTD	FE	4.1L Petrol	Auto	10-84	06-89	FOR43232	197	FOR43234	197	CNX005		RDX083	
MAVERICK	DA	4.2L Diesel	Man	02-88	02-95	NIS41007	203			CNX022	CNX023	RDX226	RDX027

MODEL	SERIES	ENGINE	TRANS	YEAR FROM	YEAR TO	RADIATOR OPTION 1	PAGE	RADIATOR OPTION 2	PAGE	CONDENSER OPTION 1	CONDENSER OPTION 2	RECEIVER DRIER OPTION 1	RECEIVER DRIER OPTION 2
FORD (continued)													
MAVERICK	DA	4.2L Petrol	Man	02-88	02-95	NIS41005	203			CNX023	CNX022	RDY027	RDY221
METEOR	GA	1.5L Petrol	Man	04-82	04-84	MAZ40051	203					RDY022	
METEOR	GB	1.5L Petrol	Man	05-83	10-85	MAZ40051	203					RDY022	
METEOR	GC	1.6L Petrol	Auto	10-85	09-87	M14CA	203			CNX006		RDY022	
METEOR	GC	1.6L Petrol	Man	10-85	09-87	M13CM	202			CNX006		RDY022	
MONDEO		2.0L Petrol	Auto	01-95	12-95	FOR1811	204						
MONDEO		2.0L Petrol	Man	01-95	12-95	FOR1811	204						
MONDEO	HB	2.0L Petrol	Auto	07-95	12-96	FOR1811	204			CNX751		RDY091	
MONDEO	HB	2.0L Petrol	Man	07-95	12-96	FOR1811	204			CNX751		RDY091	
MONDEO	HC	2.0L Petrol	Auto	12-96	12-98	FOR1811	204					RDY756	
MONDEO	HC	2.0L Petrol	Man	12-96	12-98	FOR1811	204					RDY756	
MONDEO	HD	2.0L Petrol	Auto	12-98	02-00	FOR1811	204					RDY756	
MONDEO	HD	2.0L Petrol	Man	12-98	02-00	FOR1811	204					RDY756	
MONDEO	HE	2.0L Petrol	Auto	02-00	04-01	FOR1811	204					RDY756	
MONDEO	HE	2.0L Petrol	Man	02-00	04-01	FOR1811	204					RDY756	
PROBE	ST	2.5L Petrol	Auto	07-94	03-96	M42CA	204						
PROBE	ST	2.5L Petrol	Man	07-94	03-96	M42CA	204						
PROBE	SU	2.5L Petrol	Auto	03-96	03-97	M42CA	204						
PROBE	SU	2.5L Petrol	Man	03-96	03-97	M42CA	204						
PROBE	SV	2.5L Petrol	Auto	03-97	08-98	M42CA	204						
PROBE	SV	2.5L Petrol	Man	03-97	08-98	M42CA	204						
RAIDER	UV	2.6L Petrol	Auto	01-92	11-96	MAZ40400	190						
RAIDER	UV	2.6L Petrol	Man	08-91	11-96	MAZ40350	190			CNX008			
RANGER	PJ	2.5L Turbo Diesel	Man	11-06	03-09	FOR40319	189						
RANGER	PJ	3.0L Turbo Diesel	Auto	12-06	01-10	FOR40318	188						

MODEL	SERIES	ENGINE	TRANS	YEAR FROM	YEAR TO	RADIATOR OPTION 1	PAGE	RADIATOR OPTION 2	PAGE	CONDENSER OPTION 1	CONDENSER OPTION 2	RECEIVER DRIER OPTION 1	RECEIVER DRIER OPTION 2
RANGER	PJ	3.0L Turbo Diesel	Man	11-06		FOR40318	188	FOR40319	189			RDX191	
RANGER	PK	2.5L Turbo Diesel	Auto	03-09		FOR40318	188						
RANGER	PK	2.5L Turbo Diesel	Man	03-09		FOR40319	189						
RANGER	PK	3.0L Turbo Diesel	Auto	03-09		FOR40318	188						
RANGER	PK	3.0L Turbo Diesel	Man	03-09		FOR40318	188	FOR40319	189			RDX191	
TELSTAR	AR	2.0L Petrol	Man	05-83	09-85	M10CM	205					RDX086	
TELSTAR	AS	2.0L Petrol	Man	09-85	10-87	M10CM	205					RDX086	
TELSTAR	AX	2.0L Petrol	Auto	12-92	07-96	MAZ40125	205			CNX102		RDX087	
TELSTAR	AX	2.0L Petrol	Man	12-92	07-96	MAZ40125	205			CNX102		RDX087	
TELSTAR	AX	2.5L Petrol	Auto	12-92	07-96	MAZ40130	205	MAZ40135	187	CNX102		RDX087	
TELSTAR	AX	2.5L Petrol	Man	12-92	07-96	MAZ40130	205	MAZ40135	187	CNX102		RDX087	
TELSTAR	AY	2.0L Petrol	Auto	12-92	07-96	MAZ40125	205			CNX103		RDX182	
TELSTAR	AY	2.0L Petrol	Man	12-92	07-96	MAZ40125	205			CNX103		RDX182	
TELSTAR	AY	2.5L Petrol	Auto	12-92	07-96	MAZ40130	205	MAZ40135	187	CNX103		RDX182	
TELSTAR TX5	AR	2.0L Petrol	Man	05-83	09-85	M10CM	205					RDX086	
TELSTAR TX5	AS	2.0L Petrol	Man	09-85	10-87	M10CM	205					RDX086	
TELSTAR TX5	AS	2.0L Turbo Petrol	Man	09-85	10-87	M10CM	205					RDX086	
TELSTAR TX5	AY	2.0L Petrol	Auto	01-92	07-96	MAZ40125	205			CNX103		RDX182	
TELSTAR TX5	AY	2.5L Petrol	Auto	01-92	07-96	MAZ40135	187			CNX103		RDX182	
TELSTAR TX5	AY	2.5L Petrol	Man	01-92	07-96	MAZ40135	187			CNX103		RDX182	
TERRITORY	SX	4.0L Petrol	Auto	04-04	10-05	FOR43295	195	FOR00610	194	CNX8300		RDX759	
TERRITORY	SY	4.0L Petrol	Auto	05-09		M44CA	195	FOR43292	194	CNX8300		RDX759	
TERRITORY	SY	4.0L Turbo Petrol	Auto	06-06	03-10	M44CA	195	FOR43292	194	CNX8300		RDX759	
TRANSIT	125	4.1L Petrol		09-78	12-83	FOR15471	207						
TRANSIT	VE	2.5L Diesel	Auto	12-94	04-97	FOR2219	208						

MODEL	SERIES	ENGINE	TRANS	YEAR FROM	YEAR TO	RADIATOR OPTION 1	PAGE	RADIATOR OPTION 2	PAGE	CONDENSER OPTION 1	CONDENSER OPTION 2	RECEIVER DRIER OPTION 1	RECEIVER DRIER OPTION 2
FORD (continued)													
TRANSIT	VF	2.5L Turbo Diesel	Man	04-96	01-97	FOR15471	207	FOR20221	207	CNX755		RDX750	
TRANSIT	VG	2.5L Turbo Diesel	Man	01-97	12-00	FOR15471	207	FOR20221	207	CNX755		RDX750	
TRANSIT	VH	2.3L Petrol	Man	12-00	04-05	FOR64111	207						
TRANSIT	VH	2.4L Turbo Diesel	Man	12-00	04-05	FOR64111	207	FOR5281	207	CNX773		RDX751	
TRANSIT	VJ	2.3L Petrol	Man	04-04	09-06	FOR64111	207						
TRANSIT	VJ	2.4L Turbo Diesel	Man	04-04	12-06	FOR64111	207						
FREIGHTLINER													
CENTURY CLASS	C112	12.0L Turbo Diesel	Man	01-99		FRE61591	208						
CENTURY CLASS	C120	12.7L Turbo Diesel	Man	01-99		FRE61591	208						
CENTURY CLASS	C120	6.4L Turbo Diesel	Man	01-01	12-01	FRE61591	208						
CENTURY CLASS	CST112	12.8L Turbo Diesel	Man	01-12		FRE61591	208						
CENTURY CLASS	CST120	14.0L Turbo Diesel	Man	01-04		FRE61591	208						
CENTURY CLASS	CST120	14.0L Diesel	Man	01-10		FRE61591	208						
COLUMBIA	CL112	12.7L Turbo Diesel	Man	01-04		FRE53451	209					RDX542	
COLUMBIA	CL112	8.9L Turbo Diesel	Man	01-12		FRE53451	209						
COLUMBIA	CL120	12.7L Turbo Diesel	Man	01-04	01-07	FRE53451	209					RDX542	
COLUMBIA	CL120	14.0L Diesel	Man	01-10		FRE53451	209						
FL106		8.5L Turbo Diesel	Man	01-95	12-96	FRE53341	208					RDX542	
FL80		8.3L Turbo Diesel	Auto	01-95	01-07	FRE53471	209					RDX530	
FL80		8.3L Turbo Diesel	Man	01-96	01-07	FRE53471	209					RDX530	
HINO													
RANGER 10	FG1J	8.0L Turbo Diesel	Man	02-03		HIN1123	209						

MODEL	SERIES	ENGINE	TRANS	YEAR FROM	YEAR TO	RADIATOR OPTION 1	PAGE	RADIATOR OPTION 2	PAGE	CONDENSER OPTION 1	CONDENSER OPTION 2	RECEIVER DRIER OPTION 1	RECEIVER DRIER OPTION 2
RANGER 10	PRO	8.0L Turbo Diesel	Auto	01-03	12-08	HIN1244	209						
RANGER 10	PRO	8.0L Turbo Diesel	Man	01-03	12-08	HIN1244	209						
RANGER 12	PRO	8.0L Turbo Diesel	Man	01-03	12-08	HIN1244	209						
RANGER 14	PRO	8.0L Turbo Diesel	Auto	01-03	12-08	HIN1244	209						
RANGER 14	PRO	8.0L Turbo Diesel	Man	01-03	12-08	HIN1244	209						
RANGER 5	FT1J	8.0L Turbo Diesel	Man	02-03		HIN1123	209			CNX856			
RANGER 5	PRO	5.3L Turbo Diesel	Man	01-03	12-08	HIN1244	209						
RANGER 5	PRO	8.0L Turbo Diesel	Man	01-03	12-08	HIN1244	209						
RANGER 50	PRO	1.3L Turbo Diesel	Man	01-03	12-03	HIN1244	209						
RANGER 50	PRO	12.9L Turbo Diesel	Man	01-04	12-08	HIN1244	209						
RANGER 6		8.0L Turbo Diesel	Man	03-00	01-03	HIN1123	209						
RANGER 6	FD1J	8.0L Turbo Diesel	Man	01-97	12-02	HIN1123	209						
RANGER 6	PRO	8.0L Turbo Diesel	Man	01-03	12-08	HIN1244	209						
RANGER 7	GD1G	8.0L Turbo Diesel	Man	01-03		HIN1123	209						
RANGER 7	PRO	8.0L Turbo Diesel	Man	01-03	12-08	HIN1244	209						
RANGER 8	PRO	8.0L Turbo Diesel	Man	01-03	12-08	HIN1244	209						
RANGER 9	FG1J	8.0L Turbo Diesel	Man	01-96	12-02	HIN1123	209						
RANGER 9	GHTJ	8.0L Turbo Diesel	Man	11-93	01-03	HIN1123	209						
RANGER 9	PRO	8.0L Turbo Diesel	Auto	01-03	12-08	HIN1244	209						
RANGER 9	PRO	8.0L Turbo Diesel	Man	01-03	12-08	HIN1244	209						
HOLDEN													
ADVENTRA	VY	5.7L Petrol	Auto	09-03	02-05	HOL3322C	221	HOL24820	210	CNX228			RDX117
ADVENTRA	VZ	3.6L Petrol	Auto	02-05	01-09	HOL3326C	210	HOL24850	210	CNX231			RDX106
ADVENTRA	VZ	5.7L Petrol	Auto	02-05	01-06	HOL3325C	210	HOL24870	210	CNX231			RDX106
APOLLO	JK	2.0L Petrol	Auto	01-89	08-91	TOY60226	211			CNX051			RDX161

Vehicle Application Guide

MODEL	SERIES	ENGINE	TRANS	YEAR FROM	YEAR TO	RADIATOR OPTION 1	PAGE	RADIATOR OPTION 2	PAGE	CONDENSER OPTION 1	CONDENSER OPTION 2	RECEIVER DRIER OPTION 1	RECEIVER DRIER OPTION 2
HOLDEN (continued)													
APOLLO	JK	2.0L Petrol	Man	08-89	08-91	TOY60228	211			CNX051			RDX161
APOLLO	JL	2.0L Petrol	Auto	08-91	02-93	TOY60226	211			CNX061			RDX161
APOLLO	JL	2.0L Petrol	Man	08-91	02-93	TOY60228	211			CNX061			RDX161
APOLLO	JM	2.2L Petrol	Auto	02-93	09-95	TOY60230	211	15-TOY60230	211	CNX055			RDX281
APOLLO	JM	2.2L Petrol	Man	02-93	09-95	TOY60232	211			CNX055			RDX281
APOLLO	JM	3.0L Petrol	Auto	02-93	09-95	TOY60230	211	15-TOY60230	211	CNX055			RDX281
APOLLO	JP	2.2L Petrol	Auto	09-95	06-97	TOY60230	211	15-TOY60230	211	CNX055			RDX281
APOLLO	JP	2.2L Petrol	Man	09-95	06-97	TOY60232	211			CNX055			RDX281
APOLLO	JP	3.0L Petrol	Auto	09-95	06-97	TOY60230	211	15-TOY60230	211	CNX055			RDX281
ASTRA	AH	1.8L Petrol	Auto	07-05	02-08	HOL45771	212			CNX203			RDX0050
ASTRA	AH	1.8L Petrol	Auto	11-04	03-07	HOL45771	212			CNX203			RDX0050
ASTRA	AH	1.8L Petrol	Man	07-05	02-08	HOL54081	212			CNX203			RDX0050
ASTRA	AH	1.9L Turbo Diesel	Man	05-06	12-09	HOL12601	211			CNX202			
ASTRA	AH	2.0L Turbo Petrol	Man	05-06		HOL10311	212						
ASTRA	AH	2.2L Petrol	Auto	01-06	12-09	HOL10321	212	HOL23015	213				
ASTRA	AH	2.2L Petrol	Man	01-06	12-09	HOL10311	212						
ASTRA	LC	1.6L Petrol	Auto	04-86	05-88	NIS40025	213	NIS46150	214				RDX029
ASTRA	LC	1.6L Petrol	Man	04-86	05-88	NIS40025	213	NIS46150	214				RDX029
ASTRA	LD	1.6L Petrol	Auto	07-87	07-89	NIS40025	213	NIS46150	214				RDX025
ASTRA	LD	1.6L Petrol	Man	07-87	01-90	NIS40025	213	NIS46150	214				RDX025
ASTRA	LD	1.8L Petrol	Auto	07-87	07-89	NIS40025	213	NIS46150	214				RDX025
ASTRA	LD	1.8L Petrol	Man	07-87	07-89	NIS40025	213	NIS46150	214				RDX025
ASTRA	TR	1.6L Petrol	Auto	08-96	09-98	HOL23010	213			CNX031			RDX107
ASTRA	TR	1.6L Petrol	Man	08-96	09-98	HOL23012	213			CNX031			RDX107

MODEL	SERIES	ENGINE	TRANS	YEAR FROM	YEAR TO	RADIATOR OPTION 1	PAGE	RADIATOR OPTION 2	PAGE	CONDENSER OPTION 1	CONDENSER OPTION 2	RECEIVER DRIER OPTION 1	RECEIVER DRIER OPTION 2
ASTRA	TR	1.8L Petrol	Auto	08-96	09-98	HOL23010	213			CNX031		RDX107	
ASTRA	TR	1.8L Petrol	Man	08-96	09-98	HOL23012	213			CNX031		RDX107	
ASTRA	TR	2.0L Petrol	Man	08-96	09-98	HOL23012	213	NIS40028	324	CNX031		RDX107	
ASTRA	TS	1.8L Petrol	Auto	09-98	04-06	HOL10321	212	HOL23015	213	CNX206		RDX114	
ASTRA	TS	1.8L Petrol	Man	09-98	04-06	HOL10311	212			CNX206		RDX114	
ASTRA	TS	2.0L Turbo Petrol	Man	04-03	06-04	HOL10311	212			CNX206		RDX119	
ASTRA	TS	2.2L Petrol	Auto	01-01	12-06	HOL10321	212	HOL10331	212	CNX206		RDX119	
ASTRA	TS	2.2L Petrol	Man	01-01	12-06	HOL10311	212			CNX206		RDX119	
BARINA	MB	1.3L Petrol	Man	02-85	09-86	HOL1260	216	HOL1791	216			RDX086	
BARINA	MF	1.3L Petrol	Auto	01-89	09-91	HOL25206	215			CNX223		RDX283	
BARINA	MF	1.3L Petrol	Man	01-89	09-91	HOL1260	216	SUZ58110	215	CNX223		RDX283	
BARINA	MH	1.3L Petrol	Man	09-91	04-95	HOL1260	216	SUZ58110	215	CNX223		RDX223	
BARINA	MJ	1.2L Petrol	Man	10-10		HOL25206	215						
BARINA	ML	1.3L Petrol	Man	09-86	02-90	HOL1260	216	HOL1791	216			RDX160	
BARINA	SB	1.2L Petrol	Man	01-96	12-96	HOL25206	215	HOL12001	215	CNX049		RDX108	
BARINA	SB	1.4L Petrol	Auto	01-94	12-00	HOL25200	215	HOL25205	215	CNX049		RDX108	
BARINA	SB	1.4L Petrol	Man	01-94	12-00	HOL25206	215	HOL12001	215	CNX049		RDX108	
BARINA	SB	1.6L Petrol	Man	04-94	09-99	HOL25206	215	HOL12001	215	CNX049		RDX108	
BARINA	TK	1.6L Petrol	Auto	10-05	05-08	DAE0003	179			CNX158			
BARINA	TK	1.6L Petrol	Man	02-06	05-09	DAE0003	179	DAE1009	179	CNX158			
BARINA	XC	1.4L Petrol	Auto	04-01	10-05	HOL14371	214			CNX229		RDX110	
BARINA	XC	1.4L Petrol	Man	01-04	10-05	HOL14341	214	HOL14361	214	CNX229		RDX110	RDX165
BARINA	XC	1.8L Petrol	Man	09-01	10-05	HOL14341	214	HOL14361	214	CNX229		RDX110	
BERLINA	VE	3.0L Petrol	Auto	08-09		HOL33431	217	HOL24882	217	CNX235		RDX113	
BERLINA	VE	3.6L Petrol	Auto	05-08	11-08	HOL33431	217	HOL24882	217	CNX235		RDX113	
BERLINA	VE	3.6L LPG	Auto	09-06		HOL33431	217	HOL24882	217	CNX235		RDX113	

MODEL	SERIES	ENGINE	TRANS	YEAR FROM	YEAR TO	RADIATOR OPTION 1	PAGE	RADIATOR OPTION 2	PAGE	CONDENSER OPTION 1	CONDENSER OPTION 2	RECEIVER DRIER OPTION 1	RECEIVER DRIER OPTION 2
HOLDEN (continued)													
BERLINA	VE	6.0L Petrol	Auto	07-06	11-08	HOL24885	218			CNX235			RDX113
BERLINA	VL	5.0L Petrol	Auto	03-86	08-88	HOL26270	226						RDX033
BERLINA	VX	3.8L Petrol	Auto	08-00	08-01	HOL24700	221	HOL24710	222	CNX030			RDX106
BERLINA	VX	5.7L Petrol	Auto	08-00	08-01	HOL24710	222	HOL3299C	222	CNX030			RDX106
BERLINA	VY	3.8L Petrol	Auto	08-03	08-04	HOL3320C	220	HOL24800	219	CNX228			RDX117
BERLINA	VY	5.7L Petrol	Auto	08-03	08-04	HOL3322C	221	HOL24820	210	CNX228			RDX117
BERLINA	VZ	3.6L Petrol	Auto	08-04	04-08	HOL3326C	210	HOL24850	210	CNX231			RDX106
BERLINA	VZ	5.7L Petrol	Auto	08-04	01-06	HOL3325C	210	HOL24870	210	CNX231			RDX106
BERLINA	VZ	6.0L Petrol	Auto	01-06	04-07	HOL3325C	210	HOL24870	210	CNX231			RDX106
CALAIS	VE	3.6L Petrol	Auto	08-09		HOL33431	217	HOL24882	217	CNX235			RDX113
CALAIS	VE	6.0L Petrol	Auto	07-06	11-09	HOL24885	218						
CALAIS	VK	3.3L Petrol	Auto	09-84	03-87	HOL26260	226						
CALAIS	VN	3.8L Petrol	Auto	08-88	10-91	HOL24100	226			CNX027			RDX104
CALAIS	VN	3.8L Petrol	Man	08-88	10-91	HOL24100	226			CNX027			RDX104
CALAIS	VN	5.0L Petrol	Auto	03-89	10-91	HOL24400	226	HOL26270	226				
CALAIS	VN	5.0L Petrol	Man	03-89	10-91	HOL24400	226	HOL26270	226				
CALAIS	VP	3.8L Petrol	Auto	10-91	07-93	HOL24200	225			CNX027			RDX104
CALAIS	VP	3.8L Petrol	Man	10-91	07-93	HOL24200	225			CNX027			RDX104
CALAIS	VP	5.0L Petrol	Auto	10-91	07-93	HOL24400	226	HOL26270	226				
CALAIS	VP	5.0L Petrol	Man	10-91	07-93	HOL24400	226	HOL26270	226				
CALAIS	VR	3.8L Petrol	Auto	07-93	04-95	HOL24200	225			CNX027			RDX104
CALAIS	VR	3.8L Petrol	Man	07-93	04-95	HOL24200	225			CNX027			RDX104
CALAIS	VR	5.0L Petrol	Auto	07-93	04-95	HOL24400	226	HOL26270	226				
CALAIS	VR	5.0L Petrol	Man	07-93	04-95	HOL24400	226	HOL26270	226				

MODEL	SERIES	ENGINE	TRANS	YEAR FROM	YEAR TO	RADIATOR OPTION 1	PAGE	RADIATOR OPTION 2	PAGE	CONDENSER OPTION 1	CONDENSER OPTION 2	RECEIVER DRIER OPTION 1	RECEIVER DRIER OPTION 2
CALAIS	VS	3.8L Petrol	Auto	04-95	08-97	HOL24200	225			CNX028		RDX101	
CALAIS	VS	5.0L Petrol	Auto	04-95	08-97	HOL24400	226						
CALAIS	VT	3.8L Petrol	Auto	08-97	05-00	HOL24500	224	HOL24600	223	CNX030		RDX106	
CALAIS	VT	5.0L Petrol	Auto	08-97	05-00	HOL24520	223	HOL3292C	223	CNX030		RDX106	
CALAIS	VT	5.7L Petrol	Auto	06-99	10-00	HOL24540	225	HOL3293C	224	CNX030		RDX106	
CALAIS	VX	3.8L Petrol	Auto	08-00	08-01	HOL24700	221	HOL3298C	222	CNX030		RDX106	
CALAIS	VX	5.7L Petrol	Auto	08-00	08-01	HOL24710	222	HOL3299C	222	CNX030		RDX106	
CALAIS	VY	3.8L Petrol	Auto	08-03	08-04	HOL3320C	220	HOL24800	219	CNX228		RDX117	
CALAIS	VY	5.7L Petrol	Auto	09-02	08-03	HOL3322C	221	HOL24820	210	CNX228		RDX117	
CALAIS	VZ	3.6L Petrol	Auto	08-04	07-06	HOL3326C	210	HOL24850	210	CNX231		RDX106	
CALAIS	VZ	5.7L Petrol	Auto	08-04	01-06	HOL3325C	210	HOL24870	210	CNX231		RDX106	
CALAIS	VZ	6.0L Petrol	Auto	01-06	07-06	HOL3325C	210	HOL24870	210	CNX231		RDX106	
CAPRICE	VQ	5.0L Petrol	Auto	01-92	03-94	HOL24400	226	HOL26270	226	CNX029		RDX104	
CAPRICE	VR	3.8L Petrol	Auto	03-94	04-95	HOL24200	225			CNX028		RDX101	
CAPRICE	VR	5.0L Petrol	Auto	03-94	04-95	HOL24400	226	HOL26270	226	CNX028		RDX101	
CAPRICE	VS	3.8L Petrol	Auto	04-95	06-99	HOL24200	225	HOL24300	225	CNX028		RDX101	
CAPRICE	VS	5.0L Petrol	Auto	01-95	06-99	HOL24400	226			CNX028		RDX101	
CAPRICE	WH	3.8L Petrol	Auto	06-99	08-01	HOL24500	224	HOL24700	221	CNX030		RDX106	
CAPRICE	WH	5.7L Petrol	Auto	06-99	08-01	HOL24710	222	HOL24800	219	CNX030		RDX106	
CAPRICE	WK	3.8L Petrol	Auto	04-03	08-04	HOL3320C	220	HOL24800	219			RDX117	
CAPRICE	WK	5.7L Petrol	Auto	04-03	08-04	HOL3322C	221	HOL24820	210			RDX117	
CAPRICE	WL	3.6L Petrol	Auto	08-04	08-06	HOL3326C	210	HOL24850	210				
CAPRICE	WL	5.7L Petrol	Auto	08-04	01-06	HOL3325C	210	HOL24870	210	CNX231		RDX106	
CAPRICE	WL	6.0L Petrol	Auto	01-06	08-06	HOL24885	218	HOL24885	218				
CAPRICE	WM	3.6L Petrol	Auto	08-06	11-09	HOL33431	217	HOL24882	217	CNX235	CNX235	RDX113	RDX113

MODEL	SERIES	ENGINE	TRANS	YEAR FROM	YEAR TO	RADIATOR OPTION 1	PAGE	RADIATOR OPTION 2	PAGE	CONDENSER OPTION 1	CONDENSER OPTION 2	RECEIVER DRIER OPTION 1	RECEIVER DRIER OPTION 2
HOLDEN (continued)													
CAPRICE	WM	6.0L Petrol	Auto	08-06	11-09	HOL24885	218	HOL24885	218	CNX235	CNX235	RDX113	RDX113
COLORADO		3.0L Turbo Diesel	Man	07-08		HOL1964				CNX236	CNX239	RDX118	RDX118
COLORADO	RC	3.0L Turbo Diesel	Auto	07-08		HOL1964				CNX239			
COLORADO	RC	3.0L Turbo Diesel	Man	07-08		HOL1964				CNX236	CNX239		
COMBO	SB	1.4L Petrol	Man	01-96	09-02	HOL25206	215	HOL12001	215	CNX049		RDX108	RDX108
COMBO	XC	1.4L Petrol	Man	12-04		HOL14341	214					RDX165	
COMBO	XC	1.6L Petrol	Man	09-02	01-06	HOL14361	214			CNX306		RDX110	
COMBO VAN	XC	1.4L Petrol	Man	01-06	10-07	HOL14341	214					RDX165	
COMMODORE	VB	2.8L Petrol	Auto	11-78	06-81	HOL26260	226					RDX033	
COMMODORE	VB	2.8L Petrol	Man	11-78	06-81	HOL26260	226					RDX033	
COMMODORE	VB	3.3L Petrol	Auto	11-78	06-81	HOL26260	226					RDX033	
COMMODORE	VB	3.3L Petrol	Man	11-78	06-81	HOL26260	226					RDX033	
COMMODORE	VC	1.9L Petrol	Auto	06-80	10-81	HOL26260	226			CNX305		RDX025	
COMMODORE	VC	1.9L Petrol	Man	06-80	10-81	HOL26260	226			CNX305		RDX025	
COMMODORE	VC	2.8L Petrol	Auto	06-80	10-81	HOL26260	226			CNX305		RDX025	
COMMODORE	VC	2.8L Petrol	Man	06-80	10-81	HOL26260	226			CNX305		RDX025	
COMMODORE	VC	3.3L Petrol	Auto	06-80	10-81	HOL26260	226			CNX305		RDX025	
COMMODORE	VC	3.3L Petrol	Man	06-80	10-81	HOL26260	226			CNX305		RDX025	
COMMODORE	VE	3.0L Petrol	Auto	08-09		HOL33431	217	HOL24882	217	CNX235		RDX113	
COMMODORE	VE	3.6L Petrol	Auto	01-07	09-09	HOL33431	217	HOL24882	217	CNX235		RDX113	
COMMODORE	VE	3.6L Petrol	Auto	07-06		HOL33431	217	HOL24882	217	CNX235		RDX113	
COMMODORE	VE	3.6L Petrol	Man	01-07		HOL33451	217	HOL24883	217	CNX235		RDX113	
COMMODORE	VE	6.0L Petrol	Auto	05-08	11-08	HOL24885	218			CNX235		RDX113	
COMMODORE	VE	6.0L Petrol	Man	05-08		HOL24886	218			CNX235		RDX113	

MODEL	SERIES	ENGINE	TRANS	YEAR FROM	YEAR TO	RADIATOR OPTION 1	PAGE	RADIATOR OPTION 2	PAGE	CONDENSER OPTION 1	CONDENSER OPTION 2	RECEIVER DRIER OPTION 1	RECEIVER DRIER OPTION 2
COMMODORE	VH	1.9L Petrol	Auto	10-81	09-84	HOL26260	226			CNX305		RDX025	
COMMODORE	VH	1.9L Petrol	Man	10-81	09-84	HOL26260	226			CNX305		RDX025	
COMMODORE	VH	2.8L Petrol	Auto	10-81	09-84	HOL26260	226			CNX305		RDX025	
COMMODORE	VH	2.8L Petrol	Man	10-81	09-84	HOL26260	226			CNX305		RDX025	
COMMODORE	VH	3.3L Petrol	Auto	10-81	09-84	HOL26260	226			CNX305		RDX025	
COMMODORE	VH	3.3L Petrol	Man	10-81	09-84	HOL26260	226			CNX305		RDX025	
COMMODORE	VK	3.3L Petrol	Auto	09-84	03-86	HOL26260	226			CNX305		RDX033	
COMMODORE	VK	3.3L Petrol	Man	09-84	03-86	HOL26260	226			CNX305		RDX033	
COMMODORE	VL	5.0L Petrol	Auto	03-86	08-88	HOL26270	226					RDX033	
COMMODORE	VL	5.0L Petrol	Man	03-86	01-88	HOL26270	226			CNX039		RDX033	
COMMODORE	VN	3.8L Petrol	Auto	08-88	10-91	HOL24100	226			CNX027		RDX104	
COMMODORE	VN	3.8L Petrol	Man	08-88	10-91	HOL24100	226			CNX027		RDX104	
COMMODORE	VN	5.0L Petrol	Auto	03-89	10-91	HOL24400	226	HOL26270	226	CNX029		RDX104	
COMMODORE	VN	5.0L Petrol	Man	11-90	10-91	HOL24400	226	HOL26270	226	CNX029		RDX104	
COMMODORE	VP	3.8L Petrol	Auto	10-91	07-93	HOL24200	225			CNX027		RDX104	
COMMODORE	VP	3.8L Petrol	Man	10-91	07-93	HOL24200	225			CNX027		RDX104	
COMMODORE	VP	5.0L Petrol	Auto	10-91	07-93	HOL24400	226	HOL26270	226	CNX029		RDX104	
COMMODORE	VP	5.0L Petrol	Man	10-91	07-93	HOL24400	226	HOL26270	226	CNX029		RDX104	
COMMODORE	VR	3.8L Petrol	Auto	07-93	04-95	HOL24200	225			CNX028		RDX101	
COMMODORE	VR	3.8L Petrol	Man	07-93	04-95	HOL24200	225			CNX028		RDX101	
COMMODORE	VR	5.0L Petrol	Auto	07-93	04-95	HOL24400	226	HOL26270	226	CNX028		RDX101	
COMMODORE	VR	5.0L Petrol	Man	07-93	04-95	HOL24400	226	HOL26270	226	CNX028		RDX101	
COMMODORE	VS	3.8L Petrol	Auto	04-95	08-97	HOL24200	225	HOL24300	225	CNX028		RDX101	
COMMODORE	VS	3.8L Petrol	Man	04-95	08-97	HOL24200	225	HOL24300	225	CNX028		RDX101	
COMMODORE	VS	5.0L Petrol	Auto	04-95	04-99	HOL24400	226			CNX028		RDX101	

Vehicle Application Guide

MODEL	SERIES	ENGINE	TRANS	YEAR FROM	YEAR TO	RADIATOR OPTION 1	PAGE	RADIATOR OPTION 2	PAGE	CONDENSER OPTION 1	CONDENSER OPTION 2	RECEIVER DRIER OPTION 1	RECEIVER DRIER OPTION 2
HOLDEN (continued)													
COMMODORE	VS	5.0L Petrol	Man	04-95	04-99	HOL24400	226			CNX028		RDX101	
COMMODORE	VT	3.8L Petrol	Auto	08-97	05-00	HOL24500	224	HOL24600	223	CNX030		RDX106	
COMMODORE	VT	3.8L Petrol	Man	08-97	05-00	HOL24600	223	HOL3290C	224	CNX030		RDX106	
COMMODORE	VT	5.0L Petrol	Auto	08-97	05-00	HOL24520	223	HOL3292C	223	CNX030		RDX106	
COMMODORE	VT	5.0L Petrol	Man	08-97	05-00	HOL24530	223	HOL3291C	223	CNX030		RDX106	
COMMODORE	VT	5.7L Petrol	Auto	06-99	10-00	HOL24540	225	HOL3293C	224	CNX030		RDX106	
COMMODORE	VT	5.7L Petrol	Man	06-99	10-00	HOL24550	225			CNX030		RDX106	
COMMODORE	VU	3.8L Petrol	Auto	08-01	09-02	HOL24700	221	HOL3298C	222	CNX030		RDX117	
COMMODORE	VU	3.8L Petrol	Man	08-01	09-02	HOL24705	222			CNX030		RDX117	
COMMODORE	VU	5.7L Petrol	Auto	08-01	09-02	HOL24710	222	HOL3299C	222	CNX030		RDX106	
COMMODORE	VU	5.7L Petrol	Man	08-01	09-02	HOL24715	222	HOL3300C	222	CNX030		RDX106	
COMMODORE	VX	3.8L Petrol	Auto	08-00	08-01	HOL24700	221	HOL3298C	222	CNX030		RDX106	
COMMODORE	VX	3.8L Petrol	Man	08-00	08-01	HOL24705	222			CNX030		RDX106	
COMMODORE	VX	5.7L Petrol	Auto	08-00	08-01	HOL24710	222	HOL3299C	222	CNX030		RDX106	
COMMODORE	VX	5.7L Petrol	Man	08-00	09-02	HOL24550	225	HOL24715	222	CNX030		RDX106	
COMMODORE	VY	3.8L Petrol	Auto	08-03	08-04	HOL3320C	220	HOL24800	219	CNX228		RDX117	
COMMODORE	VY	3.8L Petrol	Man	08-03	08-04	HOL3321C	220	HOL24810	220	CNX228		RDX117	
COMMODORE	VY	5.7L Petrol	Auto	09-02	08-03	HOL3322C	221	HOL24820	210	CNX228		RDX117	
COMMODORE	VY	5.7L Petrol	Man	01-03	12-03	HOL3323C	220	HOL24830	221	CNX228		RDX117	
COMMODORE	VZ	3.6L Petrol	Auto	08-04	07-06	HOL24850	210	HOL24870	210	CNX231		RDX106	
COMMODORE	VZ	3.6L Petrol	Man	08-04	10-07	HOL3327C	219	HOL24860	218	CNX231		RDX106	
COMMODORE	VZ	5.7L Petrol	Auto	08-04	12-06	HOL24850	210	HOL24870	210	CNX231		RDX106	
COMMODORE	VZ	5.7L Petrol	Man	08-04	12-06	HOL3328C	219	HOL24880	219	CNX231		RDX106	
COMMODORE	VZ	6.0L Petrol	Auto	01-06	10-07	HOL24850	210	HOL24870	210	CNX231		RDX106	
COMMODORE	VZ	6.0L Petrol	Man	01-06	10-07	HOL3328C	219	HOL24880	219	CNX231		RDX106	

MODEL	SERIES	ENGINE	TRANS	YEAR FROM	YEAR TO	RADIATOR OPTION 1	PAGE	RADIATOR OPTION 2	PAGE	CONDENSER OPTION 1	CONDENSER OPTION 2	RECEIVER DRIER OPTION 1	RECEIVER DRIER OPTION 2
COMMODORE	VZ CROSS 6	3.6L Petrol	Auto	02-05	01-06	HOL3326C	210	HOL24850	210	CNX231		RDX106	
CREWMAN	VY	3.8L Petrol	Auto	08-03	08-04	HOL3320C	220	HOL24800	219	CNX228		RDX117	
CREWMAN	VY	5.7L Petrol	Auto	08-03	08-04	HOL3322C	221	HOL24800	219	CNX228		RDX117	
CREWMAN	VY	5.7L Petrol	Man	08-03	08-04	HOL3323C	220	HOL24830	221	CNX228		RDX117	
CREWMAN	VY CROSS 8	5.7L Petrol	Auto	10-03	03-05	HOL24800	219	HOL24820	210	CNX228		RDX117	
CREWMAN	VZ	3.6L Petrol	Auto	05-05	01-09	HOL3326C	210	HOL24850	210	CNX231		RDX106	
CREWMAN	VZ	3.6L Petrol	Man	08-04	01-09	HOL3327C	219	HOL24860	218	CNX231		RDX106	
CREWMAN	VZ	6.0L Petrol	Auto	03-06	01-09	HOL3325C	210	HOL24870	210	CNX231		RDX106	
CREWMAN	VZ	6.0L Petrol	Man	03-06	01-09	HOL3328C	219	HOL24880	219	CNX231		RDX106	
CREWMAN	VZ CROSS 6	3.6L Petrol	Auto	02-05	12-06	HOL3326C	210	HOL24850	210	CNX231		RDX106	
CREWMAN	VZ CROSS 8	5.7L Petrol	Auto	02-05	01-06	HOL3325C	210	HOL24870	210	CNX231		RDX106	
CREWMAN	VZ CROSS 8	6.0L Petrol	Auto	01-06	12-06	HOL3325C	210	HOL24870	210	CNX231		RDX106	
CREWMAN	VZ S	3.6L Petrol	Auto	08-04	01-09	HOL3326C	210	HOL24850	210	CNX231		RDX106	
CREWMAN	VZ SS	5.7L Petrol	Auto	08-04	10-06	HOL3325C	210	HOL24870	210	CNX231		RDX106	
CREWMAN	VZ SS	5.7L Petrol	Man	08-04	10-06	HOL3328C	219	HOL24880	219	CNX231		RDX106	
CRUZE	YG	1.5L Petrol	Auto	07-02	06-07	H39CA	226			CNX233			
CRUZE	YG	1.5L Petrol	Man	07-02	06-07	H39CM	226			CNX233			
FRONTERA	M7	2.0L Petrol	Man	10-95	01-99	HOL08601	227						
FRONTERA	UES	2.2L Petrol	Man	02-99	01-01	HOL08601	227			CNX227		RDX610	
FRONTERA	UES	3.2L Petrol	Man	02-99	04-04	HOL08601	227			CNX227		RDX610	
JACKAROO	UBS II	3.2L Petrol	Auto	07-95	01-98	HOL1953	227			CNX050		RDX604	
JACKAROO	UBS II	3.2L Petrol	Auto	01-96	12-96	HOL1953	227			CNX050		RDX604	
JACKAROO	UBS25	3.2L Petrol	Auto	04-92	02-98	HOL1953	227			CNX050		RDX604	
JACKAROO	UBS25	3.2L Petrol	Man	04-92	02-98	HOL1953	227			CNX050		RDX604	
JACKAROO	UBS26	3.5L Petrol	Auto	02-98	04-04	HOL1765	227	HOL1953	227	CNX050		RDX604	
JACKAROO	UBS26	3.5L Petrol	Man	09-98	04-04	HOL1764	227	HOL1953	227	CNX050		RDX604	

MODEL	SERIES	ENGINE	TRANS	YEAR FROM	YEAR TO	RADIATOR OPTION 1	PAGE	RADIATOR OPTION 2	PAGE	CONDENSER OPTION 1	CONDENSER OPTION 2	RECEIVER DRIER OPTION 1	RECEIVER DRIER OPTION 2
HOLDEN (continued)													
JACKAROO	UBS69	3.1L Turbo Diesel	Man	04-92	02-98	HOL1953	227					RDx604	
JACKAROO	UBS73	3.0L Turbo Diesel	Man	01-98	04-04	HOL1764	227			CNX050		RDx604	
MONARO	V2	3.8L Petrol	Auto	12-01	01-03	HOL24700	221	HOL3298C	222	CNX030		RDx106	
MONARO	V2	5.7L Petrol	Auto	08-03	09-04	HOL24710	222	HOL3299C	222	CNX030		RDx106	
MONARO	V2	5.7L Petrol	Man	01-03	08-03	HOL24715	222	HOL24830	221	CNX030		RDx106	
MONARO	VZ	5.7L Petrol	Auto	09-04	06-06	HOL24710	222	HOL24870	210	CNX030		RDx106	
MONARO	VZ	5.7L Petrol	Man	09-04	06-06	HOL3323C	220	HOL24880	219	CNX030		RDx106	
NOVA	LE	1.4L Petrol	Man	08-89	08-91	TOY60216	228			CNX056	CNX059	RDx282	RDx284
NOVA	LE	1.6L Petrol	Auto	08-89	08-91	TOY60214	228	15-TOY60214	228	CNX056	CNX059	RDx282	RDx284
NOVA	LE	1.6L Petrol	Man	08-89	08-91	TOY60216	228			CNX056	CNX059	RDx282	RDx284
NOVA	LF	1.4L Petrol	Man	09-91	10-92	TOY60216	228			CNX056	CNX059	RDx282	RDx284
NOVA	LF	1.6L Petrol	Auto	09-91	10-94	TOY60214	228	15-TOY60214	228	CNX056	CNX059	RDx282	RDx284
NOVA	LF	1.6L Petrol	Man	09-91	10-94	TOY60216	228			CNX056	CNX059	RDx284	RDx282
NOVA	LF	1.8L Petrol	Auto	10-92	10-94	TOY60214	228	15-TOY60214	228	CNX056	CNX059	RDx284	RDx282
NOVA	LF	1.8L Petrol	Man	10-92	10-94	TOY60216	228			CNX056	CNX059	RDx284	RDx282
NOVA	LG	1.6L Petrol	Auto	10-94	09-96	TOY60218	228	E29CA2	227	CNX4640		RDx604	
NOVA	LG	1.6L Petrol	Man	10-94	09-96	TOY60220	228			CNX060		RDx604	
NOVA	LG	1.8L Petrol	Auto	10-94	09-96	TOY60218	228	E29CA2	227	CNX4640		RDx604	
NOVA	LG	1.8L Petrol	Man	10-94	09-96	TOY60220	228			CNX060		RDx604	
RODEO	G3	2.6L Petrol	Auto	01-93	11-95	HOL25050	229			CNX042			
RODEO	G3	2.6L Petrol	Man	01-93	11-95	HOL25050	229			CNX042	CNX404		
RODEO	G3	2.8L Turbo Diesel	Man	01-93	11-95	HOL25040	229			CNX042	CNX404	RDx001	
RODEO	G6	2.6L Petrol	Auto	11-95	01-97	HOL25050	229					RDx022	
RODEO	G6	2.6L Petrol	Man	11-95	01-97	HOL25050	229					RDx022	
RODEO	G6	2.8L Turbo Diesel	Man	11-95	01-97	HOL25040	229					RDx022	

MODEL	SERIES	ENGINE	TRANS	YEAR FROM	YEAR TO	RADIATOR OPTION 1	PAGE	RADIATOR OPTION 2	PAGE	CONDENSER OPTION 1	CONDENSER OPTION 2	RECEIVER DRIER OPTION 1	RECEIVER DRIER OPTION 2
RODEO	R7	2.6L Petrol	Auto	01-97	06-98	HOL25050	229					RDX022	
RODEO	R7	2.6L Petrol	Man	01-97	06-98	HOL25050	229					RDX022	
RODEO	R7	2.8L Turbo Diesel	Man	01-97	06-98	HOL25040	229			CNX230	CNX404	RDX022	
RODEO	R7	3.2L Petrol	Auto	02-98	06-98	HOL25060	229	HOL1823	227	CNX046		RDX022	
RODEO	R7	3.2L Petrol	Man	02-98	06-98	HOL25060	229	HOL1823	227	CNX046	CNX230	RDX022	
RODEO	R9	2.8L Turbo Diesel	Man	06-98	02-03	HOL25040	229			CNX046		RDX022	
RODEO	R9	3.0L Turbo Diesel	Auto	12-01	02-04	HOL2696	216					RDX001	
RODEO	R9	3.0L Turbo Diesel	Man	12-01	02-04	HOL2695	216			CNX404		RDX001	
RODEO	R9	3.0L Turbo Diesel	Man	01-02	02-03	HOL2695	216						
RODEO	R9	3.2L Petrol	Auto	06-98	02-04	HOL25060	229	HOL1823	227	CNX046		RDX022	
RODEO	R9	3.2L Petrol	Man	06-98	02-04	HOL25060	229	HOL1823	227	CNX046		RDX022	
RODEO	RA	2.4L Petrol	Man	02-03	07-08	HOL2695	216			CNX236		RDX118	
RODEO	RA	3.0L Turbo Diesel	Auto	01-07	07-08	HOL2695	216			CNX239		RDX118	
RODEO	RA	3.0L Turbo Diesel	Auto	02-03	01-07	HOL2696	216			CNX237		RDX118	
RODEO	RA	3.0L Turbo Diesel	Man	02-03	01-07	HOL2695	216			CNX237	CNX239	RDX118	
RODEO	RA	3.0L Turbo Diesel	Man	02-03	01-07	HOL2695	216			CNX237		RDX118	
RODEO	RA	3.5L Petrol	Auto	02-03	12-05	HOL2696	216			CNX236		RDX118	
RODEO	RA	3.5L Petrol	Man	02-03	12-05	HOL2695	216			CNX236		RDX118	
RODEO	RA	3.6L Petrol	Auto	01-06	07-08	HOL2696	216			CNX236		RDX118	
RODEO	RA	3.6L Petrol	Man	12-05	12-08	HOL2695	216			CNX236		RDX118	
RODEO	TF	2.6L Petrol	Auto	07-88	12-98	HOL25050	229			CNX042			
RODEO	TF	2.6L Petrol	Man	07-88	12-98	HOL25050	229			CNX402	CNX042	RDX022	
RODEO	TF	2.8L Turbo Diesel	Man	01-93	01-96	HOL25040	229			CNX042		RDX001	
RODEO	TF-G1	2.8L Turbo Diesel	Man	05-90	12-03	HOL25040	229					RDX001	
STATSMAN	VQ	3.8L Petrol	Auto	01-92	03-94	HOL24200	225			CNX027		RDX104	

MODEL	SERIES	ENGINE	TRANS	YEAR FROM	YEAR TO	RADIATOR OPTION 1	PAGE	RADIATOR OPTION 2	PAGE	CONDENSER OPTION 1	CONDENSER OPTION 2	RECEIVER DRIER OPTION 1	RECEIVER DRIER OPTION 2
HOLDEN (continued)													
STATESMAN	VQ	5.0L Petrol	Auto	03-90	01-92	HOL24400	226			CNX029		RDX104	
STATESMAN	VR	3.8L Petrol	Auto	03-94	04-95	HOL24200	225	HOL24300	225	CNX028		RDX101	
STATESMAN	VR	5.0L Petrol	Auto	03-94	04-95	HOL24400	226	HOL26270	226	CNX028		RDX101	
STATESMAN	VS	3.8L Petrol	Auto	04-95	06-99	HOL24200	225	HOL24300	225	CNX028		RDX101	
STATESMAN	VS	5.0L Petrol	Auto	04-95	06-99	HOL24400	226			CNX028		RDX101	
STATESMAN	WH	3.8L Petrol	Auto	06-99	08-01	HOL24520	223	HOL24700	221	CNX030		RDX106	
STATESMAN	WH	5.7L Petrol	Auto	06-01	08-01	HOL24540	225	HOL24710	222	CNX030		RDX106	
STATESMAN	WK	3.8L Petrol	Auto	04-03	08-04	HOL24700	221	HOL24800	219	CNX228		RDX117	
STATESMAN	WK	5.7L Petrol	Auto	04-03	08-04	HOL24700	221	HOL24820	210	CNX228		RDX117	
STATESMAN	WL	3.6L Petrol	Auto	08-04	08-06	HOL3326C	210	HOL24850	210	CNX231		RDX117	
STATESMAN	WL	5.7L Petrol	Auto	08-04	01-06	HOL3325C	210	HOL24870	210	CNX231		RDX117	
STATESMAN	WL	6.0L Petrol	Auto	01-06	08-06	HOL3325C	210	HOL24870	210	CNX231		RDX117	
STATESMAN	WM	3.6L Petrol	Auto	08-06	09-09	HOL33431	217	HOL24882	217	CNX235		RDX113	
STATESMAN	WM	6.0L Petrol	Auto	08-06	11-08	HOL24885	218			CNX235		RDX113	
TIGRA	XC	1.8L Petrol	Man	09-05	01-08	HOL14361	214						
VECTRA	JR	2.0L Petrol	Auto	06-97	08-98	HOL23005	235	HOL20641	235	CNX032		RDX109	
VECTRA	JR	2.0L Petrol	Man	06-97	08-98	HOL23007	235			CNX032		RDX109	
VECTRA	JR	2.5L Petrol	Auto	06-97	08-98	HOL23005	235	HOL20641	235	CNX032		RDX109	
VECTRA	JS	2.0L Petrol	Auto	08-98	11-00	HOL23005	235	HOL20641	235	CNX032		RDX109	
VECTRA	JS	2.0L Petrol	Man	08-98	11-00	HOL23007	235			CNX032		RDX109	
VECTRA	JS	2.2L Petrol	Auto	01-99	03-04	HOL23005	235	HOL20641	235	CNX048		RDX109	
VECTRA	JS	2.2L Petrol	Man	01-99	03-04	HOL23007	235			CNX048		RDX109	
VECTRA	JS	2.5L Petrol	Auto	08-98	11-00	HOL23005	235	HOL20641	235	CNX048		RDX109	
VECTRA	JS	2.6L Petrol	Auto	11-00	03-04	HOL23005	235	HOL20641	235	CNX048		RDX109	

MODEL	SERIES	ENGINE	TRANS	YEAR FROM	YEAR TO	RADIATOR OPTION 1	PAGE	RADIATOR OPTION 2	PAGE	CONDENSER OPTION 1	CONDENSER OPTION 2	RECEIVER DRIER OPTION 1	RECEIVER DRIER OPTION 2
VECTRA	JS	2.6L Petrol	Man	11-00	03-04	HOL23007	235			CNX048		RDX109	
VECTRA	ZC	2.2L Petrol	Auto	03-03	03-07	HOL71211	234			CNX234		RDX163	
VECTRA	ZC	2.2L Petrol	Man	03-03	03-07	HOL71211	234			CNX234		RDX163	
VECTRA	ZC	3.2L Petrol	Auto	03-03	03-07	HOL71211	234			CNX234		RDX163	
VECTRA	ZC	3.2L Petrol	Man	03-03	03-07	HOL71211	234			CNX234		RDX163	
VIVA	JF	1.8L Petrol	Auto	10-05	12-09	DAE0004	180					RDX164	
VIVA	JF	1.8L Petrol	Man	07-08	12-09	DAE1004	180					RDX164	
ZAFIRA	TT	2.2L Petrol	Auto	06-01	03-06	HOL10321	212	HOL10331	212	CNX203		RDX114	
HONDA													
ACCORD		2.0L Petrol	Auto	01-89	12-94	HON28004	237					RDX282	
ACCORD		2.0L Petrol	Auto	01-89	12-94	HON28004	237					RDX282	
ACCORD		2.3L Petrol	Auto	01-98	12-03	HON1839	237			CNX616		RDX653	
ACCORD		2.4L Petrol	Auto	12-05	06-08	HON28060	236			CNX710		RDX0050	
ACCORD	30th Anniversary	2.4L Petrol	Auto	11-05	01-06	HON28060	236			CNX710		RDX0050	
ACCORD	7th GEN	2.4L Petrol	Auto	03-07	08-07	HON28060	236			CNX0720		RDX0070	
ACCORD		2.2L Petrol	Auto	05-92	06-95	HON28004	237					RDX282	
ACCORD		2.2L Petrol	Man	05-92	04-94	HON28004	237			CNX8210		RDX282	
ACCORD		2.2L Petrol	Auto	11-89	11-93	HON28004	237					RDX282	
ACCORD		2.2L Petrol	Man	11-89	11-93	HON28004	237					RDX282	
ACCORD	CD7-CD9	2.2L Petrol	Auto	11-93	12-97	H10CA	237	HON28001	237	CNX609		RDX281	RDX653
ACCORD	CD7-CD9	2.2L Petrol	Man	11-93	12-97	H10CA	237	HON28001	237	CNX609		RDX281	RDX653
ACCORD	CE1	2.2L Petrol	Auto	11-93	12-97	H10CA	237	HON28001	237	CNX609		RDX281	RDX653
ACCORD	CE1	2.2L Petrol	Man	11-93	12-97	H10CA	237	HON28001	237	CNX609		RDX281	RDX653
ACCORD	CG5	2.3L Petrol	Auto	12-97	01-99	H10CA	237	HON28001	237	CNX616		RDX653	
ACCORD	CM5	2.4L Petrol	Auto	08-03	06-06	HON28060	236			CNX710		RDX0050	

MODEL	SERIES	ENGINE	TRANS	YEAR FROM	YEAR TO	RADIATOR OPTION 1	PAGE	RADIATOR OPTION 2	PAGE	CONDENSER OPTION 1	CONDENSER OPTION 2	RECEIVER DRIER OPTION 1	RECEIVER DRIER OPTION 2
HONDA (continued)													
ACCORD	CM6	3.0L Petrol	Auto	01-99	02-08	HON28065	237					RDX0040	
ACCORD	V6	3.5L Petrol	Auto	02-08		H64CA	236			CNX8210			
ACCORD	VTL	2.4L Petrol	Auto	01-03	02-08	HON28060	236						
ACCORD EURO		2.4L Petrol	Auto	06-08		H58CA	236			CNX710		RDX0040	
ACCORD EURO		2.4L Petrol	Man	06-08		H58CA	236			CNX710		RDX0040	
ACCORD EURO	CL9	2.4L Petrol	Auto	06-03	06-08	HON28060	236			CNX710		RDX0050	
ACCORD EURO	CL9	2.4L Petrol	Man	06-03	06-08	HON28060	236			CNX710		RDX0050	
ASCOT (NZ)		2.0L Petrol	Auto	01-89	12-95	HON28004	237						
ASCOT (NZ)		2.0L Petrol	Auto	01-89	12-95	HON28004	237						
CIVIC		1.5L Petrol	Auto	01-95	12-00	HON28018	239						
CIVIC		1.5L Petrol	Man	02-93	10-95	HON28012	239	HON28019	239			RDX120	RDX602
CIVIC	7th GEN	1.7L Petrol	Man	11-00	02-06	HON28020	239			CNX711	CNX716	RDX653	
CIVIC	8th GEN	1.8L Petrol	Auto	02-06		H55CA	238			CNX8180			
CIVIC	8th GEN	1.8L Petrol	Man	02-06		H55CM	238	H65CM	238				
CIVIC	8th GEN	2.0L Petrol	Auto	02-06		H55CA	238						
CIVIC	8th GEN	2.0L Petrol	Man	02-06		H55CM	238	H65CM	238	CNX8180		RDX0050	
CIVIC	8th GEN	2.0L Petrol	Man	06-07		HON28010	238						
CIVIC	AH	1.5L Petrol	Man	01-84	03-89	HON28017	239					RDX121	
CIVIC	AN	1.5L Petrol	Man	01-84	03-89	HON28017	239					RDX121	
CIVIC	ED	1.5L Petrol	Auto	01-87	10-93	HON28016	240	HON28018	239			RDX654	
CIVIC	ED	1.5L Petrol	Man	01-87	10-93	HON28016	240					RDX120	
CIVIC	EE	1.5L Petrol	Man	05-88	05-90	HON28017	239					RDX120	
CIVIC	EG	1.3L Petrol	Man	10-91	10-93	HON28012	239	HON28019	239			RDX120	
CIVIC	EG	1.5L Petrol	Auto	10-93	10-95	HON28018	239					RDX602	

MODEL	SERIES	ENGINE	TRANS	YEAR FROM	YEAR TO	RADIATOR OPTION 1	PAGE	RADIATOR OPTION 2	PAGE	CONDENSER OPTION 1	CONDENSER OPTION 2	RECEIVER DRIER OPTION 1	RECEIVER DRIER OPTION 2
CIVIC	EG	1.5L Petrol	Man	05-93	10-95	HON28012	239	HON28019	239			RDX602	
CIVIC	EG	1.6L Petrol	Auto	10-91	10-93	HON28018	239		239			RDX120	RDX602
CIVIC	EG	1.6L Petrol	Man	10-91	10-93	HON28012	239	HON28019	239			RDX120	RDX602
CIVIC	EH	1.6L Petrol	Auto	10-93	10-95	HON28018	239		239			RDX602	RDX120
CIVIC	EH	1.6L Petrol	Man	10-93	10-95	HON28012	239	HON28019	239			RDX602	RDX120
CIVIC	EK	1.6L Petrol	Auto	10-95	10-00	HON28018	239		239	CNX601		RDX653	
CIVIC	EK	1.6L Petrol	Man	01-95	10-00	HON28012	239	HON28019	239	CNX601		RDX653	
CIVIC	GLJ	1.6L Petrol	Auto	03-99	10-00	HON28018	239		239	CNX601		RDX653	
CIVIC	HYBRID	1.3L HYBRID	Auto	02-06		H61CA	238						
CIVIC	VTI	1.6L Petrol	Auto	03-96	03-99	HON28018	239		239				
CIVIC	VTI	1.6L Petrol	Man	03-96	03-99	HON28012	239	HON28019	239				
CIVIC	VTI-R	1.6L Petrol	Man	03-99	10-00	HON28012	239	HON28019	239	CNX601		RDX653	
CRV		2.4L Petrol	Auto	02-07		H57CA	240	HON1089	240	CNX717		RDX0040	
CRV		2.4L Petrol	Auto	12-01	10-04	H40CA	240		240	CNX717		RDX0040	
CRV		2.4L Petrol	Man	02-07		H57CM	240		240	CNX717		RDX0040	
CRV	RD1	2.0L Petrol	Auto	10-97	12-01	HON28030	241		241	CNX610		RDX653	
CRV	RD1	2.0L Petrol	Man	10-97	12-01	HON28030	241		241	CNX610		RDX653	
CRV	RD7	2.4L Petrol	Auto	10-04	02-07	H40CA	240		240	CNX717		RDX0040	
CRV	RD7	2.4L Petrol	Man	12-01	02-07	H40CM	240		240	CNX717		RDX0040	
HRV	GH2	1.6L Petrol	Man	01-99	05-02	HON28019	239		239	CNX601		RDX653	
HRV	GH4	1.6L Petrol	Man	03-00	05-02	HON28019	239		239	CNX601		RDX653	
INSIGHT		1.0L Petrol	Man	03-01	08-04	H46CA	241	H46CM	241				
INTEGRA		1.6L Petrol	Auto	01-93	12-00	HON1204	242					RDX602	
INTEGRA		1.6L Petrol	Auto	01-93	12-00	HON1204	242					RDX602	
INTEGRA		1.6L Petrol	Man	05-86	06-90	H26CM	242						
INTEGRA	DA9	1.8L Petrol	Man	06-89	07-93	H26CM	242			CNX610		RDX123	

MODEL	SERIES	ENGINE	TRANS	YEAR FROM	YEAR TO	RADIATOR OPTION 1	PAGE	RADIATOR OPTION 2	PAGE	CONDENSER OPTION 1	CONDENSER OPTION 2	RECEIVER DRIER OPTION 1	RECEIVER DRIER OPTION 2
HONDA (continued)													
INTEGRA	DC2	1.8L Petrol	Man	07-93	10-99	H34CM	242			CNX610			RDX602
INTEGRA	DC4	1.8L Petrol	Auto	07-93	08-01	HON1204	242			CNX610			RDX602
INTEGRA	DC4	1.8L Petrol	Man	01-93	08-01	H34CM	242			CNX610			RDX602
INTEGRA	DC5	2.0L Petrol	Auto	08-01	10-04	H44CA	241			CNX610			RDX653
INTEGRA	DC5	2.0L Petrol	Man	08-01	10-04	H44CM	241			CNX610			RDX653
JAZZ	GD1	1.3L Petrol	Auto	10-02	08-08	HON1789	242			CNX5590			RDX0050
JAZZ	GD1	1.3L Petrol	Man	10-02	08-08	HON1789	242			CNX5590			RDX0050
JAZZ	GD3	1.5L Petrol	Auto	10-02	08-08	HON28040	242			CNX9531			RDX0050
JAZZ	GD3	1.5L Petrol	Man	10-02	08-08	HON28040	242	HON28042	242	CNX9531			RDX0050
JAZZ	GLI	1.3L Petrol	Man	08-08		HON1789	242			CNX715			
LEGEND	KA7	3.2L Petrol	Auto	03-91	05-97	H30CA	243						
LEGEND	KA8	3.2L Petrol	Auto	04-91	05-97	H30CA	243						
LEGEND	KA9	3.5L Petrol	Auto	05-96	04-05	H43CA	243						
LEGEND	KB1	3.5L Petrol	Auto	08-06	09-08	H43CA	243						
MDX	YD1	3.5L Petrol	Auto	04-03	03-07	HON28058	243						
ODYSSEY		2.3L Petrol	Auto	02-02	12-04	H47CM	243	HON28054	243				
ODYSSEY	RA1	2.2L Petrol	Auto	06-95	01-98	H31CA	244	H38CA	244	CNX615			RDX284
ODYSSEY	RA3	2.3L Petrol	Auto	01-98	06-04	H31CA	244	HON28054	243	CNX714			RDX287
ODYSSEY	RA8	3.0L Petrol	Auto	01-00	06-04	H47CM	243	HON28054	243	CNX714			RDX287
ODYSSEY	RB1	2.4L Petrol	Auto	06-04	04-10	HON1127	243			CNX9300			RDX0040
PRELUDE		2.0L Petrol	Auto	01-87	12-93	HON28004	237						
PRELUDE		2.0L Petrol	Auto	01-87	12-93	HON28004	237						
PRELUDE		2.2L Petrol	Auto	12-91	02-97	H28CA	244						RDX025
PRELUDE		2.2L Petrol	Man	01-91	12-96	HON28004	237						

MODEL	SERIES	ENGINE	TRANS	YEAR FROM	YEAR TO	RADIATOR OPTION 1	PAGE	RADIATOR OPTION 2	PAGE	CONDENSER OPTION 1	CONDENSER OPTION 2	RECEIVER DRIER OPTION 1	RECEIVER DRIER OPTION 2
PRELUDE		2.2L Petrol	Man	01-91	12-96	HON28004	237						
PRELUDE		2.2L Petrol	Man	01-91	12-96	HON28004	237						
PRELUDE		2.2L Petrol	Man	01-91	12-96	HON28004	237						
PRELUDE	AB	2.0L Petrol	Auto	01-86	09-87	H29CA	244						
PRELUDE	BA1	2.0L Petrol	Auto	08-91	12-91	H29CA	244			CNX614		RDX414	
PRELUDE	BA4	2.0L Petrol	Auto	10-87	12-91	H29CA	244			CNX614		RDX414	
PRELUDE	BA4	2.0L Petrol	Man	10-87	12-91	H29CA	244			CNX614		RDX414	
PRELUDE	BB1	2.2L Petrol	Man	02-94	02-97	H29CA	244						
PRELUDE	BB2	2.3L Petrol	Auto	12-91	02-97	H28CA	244					RDX025	
PRELUDE	BB5	2.2L Petrol	Auto	02-97	05-02	H38CA	244			CNX617		RDX022	
HSV													
CLUBSPORT	GTS	6.0L Petrol	Auto	08-06 >		HOL24885	218			CNX235		RDX113	
CLUBSPORT	GTS	6.0L Petrol	Man	08-06 >		HOL24886	218			CNX235		RDX113	
CLUBSPORT	VP	5.0L Petrol	Man	10-91	08-93	HOL26270	226			CNX029		RDX104	
CLUBSPORT	VZ	6.0L Petrol	Auto	10-04	08-06	HOL3325C	210			CNX231		RDX106	
CLUBSPORT	VZ	6.0L Petrol	Man	10-04	08-06	HOL3328C	219			CNX231		RDX106	
COUPE GTO	VZ	6.0L Petrol	Auto	10-04	08-06	HOL3325C	210			CNX231		RDX106	
COUPE GTO	VZ	6.0L Petrol	Man	10-04	08-06	HOL3325C	210			CNX231		RDX106	
LS	VP	3.8L Petrol	Auto	09-91	12-94	HOL24200	225			CNX027		RDX104	
MALOO	VZ	6.0L Petrol	Auto	10-04	10-07	HOL3325C	210			CNX231		RDX106	
MALOO	VZ	6.0L Petrol	Man	10-04	10-07	HOL3328C	219			CNX231		RDX106	
SENATOR	VS	5.0L Petrol	Auto	04-95	09-97	HOL24400	226			CNX028		RDX101	
SENATOR	VT	5.0L Petrol	Auto	09-97	06-99	HOL24520	223	HOL3292C	223	CNX030		RDX493	
SENATOR	VT	5.0L Petrol	Man	09-97	03-00	HOL24530	223	HOL3291C	223	CNX030		RDX106	
SENATOR	VZ	6.0L Petrol	Auto	10-04	08-06	HOL3325C	210			CNX231		RDX106	

MODEL	SERIES	ENGINE	TRANS	YEAR FROM	YEAR TO	RADIATOR OPTION 1	PAGE	RADIATOR OPTION 2	PAGE	CONDENSER OPTION 1	CONDENSER OPTION 2	RECEIVER DRIER OPTION 1	RECEIVER DRIER OPTION 2
HSV (continued)													
SENATOR	VZ	6.0L Petrol	Man	01-04	12-04	HOL3328C	219			CNX231		RDX106	
SENATOR SIGNATURE	VZ	6.0L Petrol	Auto	08-06	10-07	HOL3325C	210			CNX231		RDX106	
SENATOR SIGNATURE	VZ	6.0L Petrol	Man	08-06	10-07	HOL3328C	219			CNX231		RDX106	
SV6000	VZ	6.0L Petrol	Auto	06-05	08-06	HOL3325C	210			CNX231		RDX106	
SV6000	VZ	6.0L Petrol	Man	06-05	08-06	HOL3328C	219			CNX231		RDX106	
HYUNDAI													
ACCENT	LC-S	1.6L Petrol	Auto	02-03	05-07	HYU0003	245			CNX146		RDX0050	
ACCENT	LC-S	1.6L Petrol	Man	02-03	05-07	HYU1003	245			CNX146		RDX491	
ACCENT	MC	1.6L Petrol	Auto	05-06		HYU0034	244			CNX145		RDX491	
ACCENT	MC	1.6L Petrol	Man	05-06		HYU1034	245			CNX148			
ELANTRA	HD	2.0L Petrol	Auto	09-06		HYU0035	245			CNX122		RDX0050	
ELANTRA	HD	2.0L Petrol	Man	09-06		HYU1035	245			CNX122		RDX0050	
ELANTRA	XD	1.8L Petrol	Auto	10-00	09-03	HYU30060	246	HYU0019	246	CNX147		RDX491	
ELANTRA	XD	1.8L Petrol	Man	10-00	09-03	HYU30062	246	HYU1004	246	CNX147		RDX491	
ELANTRA	XD	2.0L Petrol	Auto	09-03	09-06	HYU30060	246	HYU0019	246	CNX147		RDX491	
ELANTRA	XD	2.0L Petrol	Auto	10-00	09-03	HYU30060	246	HYU0019	246	CNX147		RDX491	
ELANTRA	XD	2.0L Petrol	Man	09-03	09-06	HYU30062	246	HYU1004	246	CNX147		RDX491	
ELANTRA LAVITA	FC	1.8L Petrol	Auto	10-01	01-04	HYU0018	245			CNX734			
ELANTRA LAVITA	FC	1.8L Petrol	Man	10-01	01-04	HYU1018	246			CNX734			
EXCEL		1.5L Petrol	Auto	07-91	01-95	HYU0005	247						
EXCEL	X1	1.5L Petrol	Auto	02-86	12-90	HYU30020	247					RDX414	
EXCEL	X1	1.5L Petrol	Man	02-86	12-90	HYU30020	247					RDX414	
EXCEL	X2	1.5L Petrol	Auto	01-90	09-94	HYU0005	247			CNX129		RDX477	

MODEL	SERIES	ENGINE	TRANS	YEAR FROM	YEAR TO	RADIATOR OPTION 1	PAGE	RADIATOR OPTION 2	PAGE	CONDENSER OPTION 1	CONDENSER OPTION 2	RECEIVER DRIER OPTION 1	RECEIVER DRIER OPTION 2
EXCEL	X2	1.5L Petrol	Man	01-90	09-94	HYU1005	247			CNX129		RDX477	
EXCEL	X3	1.5L Petrol	Auto	01-94	03-01	HYU0005	247	HYU0006	247	CNX128		RDX477	
EXCEL	X3	1.5L Petrol	Man	01-94	03-01	HYU1005	247	HYU1006	247	CNX128		RDX477	
GETZ	TB	1.3L Petrol	Auto	03-03	10-05	HYU0008	248			CNX125		RDX0040	
GETZ	TB	1.3L Petrol	Man	02-03	10-05	HYU1008	248			CNX125		RDX0040	
GETZ	TB	1.4L Petrol	Auto	10-05	10-08	HYU0008	248			CNX125		RDX0040	
GETZ	TB	1.4L Petrol	Man	12-05	10-08	HYU1008	248			CNX125		RDX0040	
GETZ	TB	1.5L Petrol	Auto	09-02	10-05	HYU0008	248			CNX125		RDX0040	
GETZ	TB	1.5L Petrol	Man	09-02	10-05	HYU1008	248			CNX125		RDX0040	
GETZ	TB	1.6L Petrol	Auto	10-05	10-08	HYU0008	248			CNX125		RDX0040	
GETZ	TB	1.6L Petrol	Man	10-05	10-08	HYU1008	248			CNX125		RDX0040	
GRANDEUR	T41	3.0L Petrol	Auto	09-99	04-03	HYU30070	248			CNX732		RDX492	
i30	FD	1.6L Turbo Diesel	Auto	10-08		HYU0035	245			CNX122			
i30	FD	1.6L Turbo Diesel	Man	03-09		HYU1035	245			CNX122		RDX0050	
i30	FD	2.0L Petrol	Auto	10-07		HYU0035	245			CNX122		RDX0050	
i30	FD	2.0L Petrol	Man	10-07		HYU1035	245			CNX122		RDX0050	
iLOAD	TQ	2.4L Petrol	Man	01-08		HYU1042	248			CNX163			
iLOAD	TQ	2.5L Turbo Diesel	Auto	01-08		HYU0042	249			CNX164			
iLOAD	TQ	2.5L Turbo Diesel	Man	01-08		HYU1043	249			CNX164			
iMAX	TQ	2.4L Petrol	Auto	01-08		HYU0042	249			CNX163			
iMAX	TQ	2.5L Turbo Diesel	Auto	11-08		HYU0043	249			CNX164			
iMAX	TQ	2.5L Turbo Diesel	Man	01-08		HYU1043	249			CNX164			
LAINTRA		1.6L Petrol	Auto	01-95	12-02	HYU0010	249						
LAINTRA		1.8L Petrol	Auto	10-92	08-95	HYU0020	249			CNX132		RDX022	

MODEL	SERIES	ENGINE	TRANS	YEAR FROM	YEAR TO	RADIATOR OPTION 1	PAGE	RADIATOR OPTION 2	PAGE	CONDENSER OPTION 1	CONDENSER OPTION 2	RECEIVER DRIER OPTION 1	RECEIVER DRIER OPTION 2
HYUNDAI (continued)													
LANTRA		1.8L Petrol	Man	10-92	08-95	HYU1020	250			CNX132			RDX022
LANTRA	J2	1.8L Petrol	Auto	09-95	02-99	HYU0010	249			CXN124	CNX143		RDX476
LANTRA	J2	1.8L Petrol	Man	09-95	02-99	HYU1010	249			CXN124	CNX143		RDX476
LANTRA	J3	1.8L Petrol	Auto	02-99	10-00	HYU0010	249			CNX143			
LANTRA	J3	1.8L Petrol	Man	02-99	10-00	HYU1010	249			CNX143			
LANTRA	J3	2.0L Petrol	Auto	02-99	10-00	HYU0010	249			CNX143			
LANTRA	J3	2.0L Petrol	Man	02-99	10-00	HYU1010	249			CNX143			
LANTRA SPORTZ	J2	1.8L Petrol	Auto	10-96	02-99	HYU0010	249			CXN124	CNX143		RDX476
S COUPE	1N	1.5L Petrol	Auto	07-90	10-92	R7CA	251	HYU0013	251				RDX478
S COUPE		1.5L Petrol	Auto	07-90	05-96	R7CA	251	HYU0013	251				RDX478
SANTA FE		2.7L Petrol	Auto	06-08		HYU1152	250						
SANTA FE	B81	2.4L Petrol	Man	01-01	09-03	HYU1012	250			CNX150			RDX491
SANTA FE	CM	2.7L Petrol	Auto	05-06	07-09	HYU1152	250						
SANTA FE	SM	2.7L Petrol	Auto	11-00	04-06	HYU30080	250	HYU0011	250				
SONATA	EF	2.0L Petrol	Auto	08-98	03-01	HYU30070	248			CNX732			RDX492
SONATA	EF	2.0L Petrol	Man	08-98	03-01	HYU30070	248			CNX732			RDX492
SONATA	EF	2.5L Petrol	Auto	08-98	09-01	HYU30070	248			CNX732			RDX492
SONATA	EF	2.5L Petrol	Man	08-98	09-01	HYU30070	248			CNX732			RDX492
SONATA	EF-B	2.4L Petrol	Auto	09-01	06-05	HYU30070	248			CNX732			
SONATA	EF-B	2.4L Petrol	Man	09-01	06-05	HYU30070	248			CNX732			
SONATA	EF-B	2.7L Petrol	Auto	09-01	06-05	HYU30070	248			CNX732			
SONATA	EF-B	2.7L Petrol	Man	09-01	06-05	HYU30070	248			CNX732			
SONATA	F21	2.0L Petrol	Auto	11-93	08-98	HYU30050	252	HYU0002	251	CNX126			RDX475
SONATA	F21	2.0L Petrol	Man	11-93	08-98	HYU1002	252			CNX126			RDX475

MODEL	SERIES	ENGINE	TRANS	YEAR FROM	YEAR TO	RADIATOR OPTION 1	PAGE	RADIATOR OPTION 2	PAGE	CONDENSER OPTION 1	CONDENSER OPTION 2	RECEIVER DRIER OPTION 1	RECEIVER DRIER OPTION 2
SONATA	F21	2.4L Petrol	Auto	03-89	12-91	HYU30050	252			CNX130			
SONATA	F21	2.4L Petrol	Man	03-89	12-91	HYU30050	252			CNX130			
SONATA	NF	2.4L Petrol	Auto	03-07	06-08	HYU0001	251			CNX161			
SONATA	NF	2.4L Petrol	Man	03-07	06-08	HYU0001	251			CNX161			
SONATA	NF	3.3L Petrol	Auto	06-05	06-08	HYU0001	251			CNX149			
TERRACAN		3.5L Petrol	Auto	11-01	01-09	HYU1206	252			CNX169			
TERRACAN		3.5L Petrol	Man	11-01	01-09	HYU1206	252			CNX169			
TERRACAN	CRDI	2.9L Turbo Diesel	Auto	01-05	01-09	HYU1205	252			CNX168			
TERRACAN	CRDI	2.9L Turbo Diesel	Man	01-05	01-09	HYU1205	252			CNX168			
TIBURON		2.0L Petrol	Auto	03-02	05-04	HYU30060	246						
TIBURON		2.0L Petrol	Man	02-02	05-04	HYU30060	246			CNX147		RDX491	
TIBURON	N61	2.7L Petrol	Auto	03-02		HYU0016	253						
TIBURON	N61	2.7L Petrol	Man	03-02		HYU1016	253			CNX147		RDX491	
TRAJET		2.7L Petrol	Auto	07-04	06-09	HYU0021	253						
TRAJET	G81	2.7L Petrol	Auto	07-00	07-04	HYU0021	253			CNX735		RDX491	
TUCSON	CITY	2.0L Petrol	Auto	11-05		HYU1510	253						
TUCSON	CITY	2.0L Petrol	Man	04-07		HYU1510	253						
TUCSON	N81	2.7L Petrol	Auto	08-04		HYU1510	253			CNX738		RDX491	
TUCSON	N81	2.7L Petrol	Man	08-04	08-08	HYU1510	253						
ISUZU													
MU		3.1L Diesel	Auto	01-93	12-99	HOL25060	229						
N	NPR400	4.6L Diesel	Man	04-98	09-00	ISU1124	254	ISU1239	254			RDX5810	RDX5811
N4	NPR200	4.3L Diesel	Man	06-96	12-00	ISU1124	254	ISU1239	254			RDX5810	RDX5811
N8	NPR200	4.3L Diesel	Man	04-98	09-00	ISU1124	254	ISU1239	254			RDX5810	RDX5811

Vehicle Application Guide

Vehicle Application Guide

MODEL	SERIES	ENGINE	TRANS	YEAR FROM	YEAR TO	RADIATOR OPTION 1	PAGE	RADIATOR OPTION 2	PAGE	CONDENSER OPTION 1	CONDENSER OPTION 2	RECEIVER DRIER OPTION 1	RECEIVER DRIER OPTION 2
ISUZU (continued)													
N8-NY	NPR250	4.6L Turbo Diesel	Auto	04-98	12-02	ISU1124	254	ISU1239	254			RDX5810	RDX5811
NY	NPR300	4.6L Diesel	Auto	04-98	12-02	ISU1124	254	ISU1239	254			RDX5810	RDX5811
NY	NPR300	4.6L Diesel	Man	04-98	12-02	ISU1124	254	ISU1239	254			RDX5810	RDX5811
IVECO													
DAILY	35C14	2.3L Turbo Diesel	Auto	01-06	04-07	IVE17551	254	IVE74431	254	CNX454			
DAILY	35C14	2.3L Turbo Diesel	Man	05-05		IVE17551	254	IVE74431	254	CNX454			
DAILY	35S13	2.8L Turbo Diesel	Man	03-02	05-05	IVE74431	254			CNX452			
DAILY	35S13V	2.8L Turbo Diesel	Man	03-02	12-07	IVE74431	254			CNX452			
DAILY	35S14	2.3L Turbo Diesel	Man	06-07		IVE17551	254	IVE74431	254				
DAILY	35S15	2.8L Turbo Diesel	Man	03-02	02-03	IVE74431	254			CNX454			
DAILY	40C13	2.8L Turbo Diesel	Man	02-03	12-07	IVE74431	254			CNX454			
DAILY	40C14	2.8L Turbo Diesel	Auto	01-06	01-07	IVE74431	254			CNX454			
DAILY	40C14	2.8L Turbo Diesel	Man	05-05	01-07	IVE74431	254			CNX454			
DAILY	40C14	3.0L Turbo Diesel	Man	05-05	04-07	IVE74431	254			CNX454			
DAILY	45C14	3.0L Turbo Diesel	Auto	01-06	01-07	IVE74431	254			CNX454			
DAILY	45C14	3.0L Turbo Diesel	Man	01-06	01-07	IVE74431	254			CNX454			
DAILY	45C15	3.0L Turbo Diesel	Man	01-08		IVE74431	254						
DAILY	45C17	3.0L Turbo Diesel	Auto	01-06	01-07	IVE74431	254			CNX454			
DAILY	45C17	3.0L Turbo Diesel	Man	01-06	01-07	IVE74431	254			CNX454			
DAILY	45C18	3.0L Turbo Diesel	Man	01-08		IVE74431	254						
DAILY	50C15	2.8L Turbo Diesel	Man	03-02	12-07	IVE74431	254			CNX452			
DAILY	50C17	2.8L Turbo Diesel	Auto	01-06	01-07	IVE74431	254			CNX454			
DAILY	50C17	2.8L Turbo Diesel	Man	05-05	01-07	IVE74431	254			CNX454			
DAILY	50C17	3.0L Turbo Diesel	Auto	01-06	04-07	IVE74431	254			CNX454			

MODEL	SERIES	ENGINE	TRANS	YEAR FROM	YEAR TO	RADIATOR OPTION 1	PAGE	RADIATOR OPTION 2	PAGE	CONDENSER OPTION 1	CONDENSER OPTION 2	RECEIVER DRIER OPTION 1	RECEIVER DRIER OPTION 2
DAILY	50C17	3.0L Turbo Diesel	Man	05-05	04-07	IVE74431	254		254	CNX454			
DAILY	50C18	3.0L Turbo Diesel	Man	04-07		IVE74431	254		254				
DAILY	65C15	2.8L Turbo Diesel	Man	02-03	12-07	IVE74431	254		254	CNX452			
DAILY	65C17	3.0L Turbo Diesel	Auto	01-06	04-07	IVE74431	254		254	CNX454			
DAILY	65C17	3.0L Turbo Diesel	Man	05-05	04-07	IVE74431	254		254	CNX454			
DAILY	65C18	3.0L Turbo Diesel	Man	04-07		IVE74431	254		254				
DAILY	SCUDERIA HPT	2.8L Turbo Diesel	Man	01-02	12-02	IVE74431	254		254	CNX454			
EUROARGO	ML100	5.9L Turbo Diesel	Man	11-98	12-08	IVE58001	255	IVE04611	255	CNX455			
EUROARGO	ML120E	5.9L Turbo Diesel	Man	01-99	12-99	IVE58001	255	IVE04611	255	CNX455			
EUROARGO	ML120E24P	5.9L Turbo Diesel	Man	07-02	12-08	IVE58001	255	IVE04611	255	CNX456			
EUROARGO	ML120E25P	5.9L Turbo Diesel	Man	01-10		IVE58001	255	IVE04611	255	CNX455			
EUROARGO	ML130E1	5.9L Turbo Diesel	Man	01-99	12-00	IVE58001	255	IVE04611	255	CNX455			
EUROARGO	ML150E2	5.9L Turbo Diesel	Man	01-99	01-03	IVE58001	255	IVE04611	255	CNX455			
EUROARGO	ML150E24FP	5.9L Turbo Diesel	Man	07-02	12-08	IVE58001	255	IVE04611	255	CNX456			
EUROARGO	ML160E28P	5.9L Turbo Diesel	Man	01-10		IVE58001	255	IVE04611	255	CNX455			
EUROARGO	ML170E23	5.9L Turbo Diesel	Man	01-02	12-02	IVE58001	255	IVE04611	255	CNX456			
EUROARGO	ML170E27	5.9L Turbo Diesel	Man	01-02	12-02	IVE58001	255	IVE04611	255	CNX456			
EUROARGO	ML180E28	5.9L Turbo Diesel	Man	07-02	12-08	IVE58001	255	IVE04611	255	CNX456			
EUROARGO	ML180E28P	5.9L Turbo Diesel	Man	01-03	12-08	IVE58001	255	IVE04611	255	CNX455			
EUROARGO	ML188E1	5.9L Turbo Diesel	Man	01-99	01-03	IVE58001	255	IVE04611	255	CNX455			
EUROARGO	ML225E28P	5.9L Turbo Diesel	Man	01-10		IVE58001	255	IVE04611	255	CNX455			
EUROARGO	ML230E28-P	5.9L Turbo Diesel	Man	01-03	12-08	IVE58001	255	IVE04611	255	CNX455			
EUROARGO	ML75	3.9L Turbo Diesel	Man	11-98	03-03	IVE58001	255	IVE04611	255	CNX455			
EUROSTAR	LD5500	17.2L Turbo Diesel	Man	01-97	01-02	IVE21581	255		255	CNX453			
EUROTECH	MP4100	7.8L Turbo Diesel	Man	01-04	01-08	IVE21611	256		256				

MODEL	SERIES	ENGINE	TRANS	YEAR FROM	YEAR TO	RADIATOR OPTION 1	PAGE	RADIATOR OPTION 2	PAGE	CONDENSER OPTION 1	CONDENSER OPTION 2	RECEIVER DRIER OPTION 1	RECEIVER DRIER OPTION 2
IVECO (continued)													
EUROTECH	MP4500	13.8L Turbo Diesel	Man	01-97	12-97	IVE21581	255	IVE21601	256				
EUROTECH	MT3500	9.5L Turbo Diesel	Man	01-97	12-97	IVE21581	255						
STRALIS	AD10	10.3L Turbo Diesel	Man	03-05		IVE21741	256						
STRALIS	AD13	12.9L Turbo Diesel	Man	03-05		IVE21741	256						
STRALIS	AD450	12.9L Turbo Diesel	Man	01-10		IVE21741	256						
STRALIS	AS13	12.9L Turbo Diesel	Man	03-05		IVE21741	256						
STRALIS	AS-L	12.9L Turbo Diesel	Man	01-10		IVE21741	256						
STRALIS	AT10	10.3L Turbo Diesel	Man	03-05		IVE21741	256						
STRALIS	AT13	12.9L Turbo Diesel	Man	03-05		IVE21741	256						
STRALIS	AT450	12.9L Turbo Diesel	Man	01-10		IVE21741	256						
STRALIS	ATI	10.3L Turbo Diesel	Man	01-10		IVE21741	256						
STRALIS	ATH435	10.3L Turbo Diesel	Man	03-05		IVE21741	256						
TURBODAILY	40.1	2.8L Turbo Diesel	Man	01-98	01-03	IVE24561	255						
TURBODAILY	49.1	2.8L Turbo Diesel	Man	10-98	01-03	IVE24561	255						
TURBODAILY	59.12	2.8L Turbo Diesel	Man	10-98	01-00	IVE24561	255						
TURBODAILY		2.8L Turbo Diesel	Man	10-98	01-02	IVE24561	255						
JAGUAR													
XK8	Classic	4.0L Petrol	Auto	11-96	10-02	JAG64041	256			CNX165			RDX147
X-TYPE	X400	2.1L Petrol	Auto	06-02		JAG64141	256						
X-TYPE	X400	2.1L Petrol	Man	06-02	11-04	JAG64141	256						
X-TYPE	X400	2.5L Petrol	Auto	01-01	12-04	JAG64141	256						
X-TYPE	X400	2.5L Petrol	Man	10-01	11-04	JAG64141	256						
X-TYPE	X400	3.0L Turbo Petrol	Auto	10-01		JAG64141	256						
X-TYPE	X400	3.0L Turbo Petrol	Man	10-01	11-04	JAG64141	256						

MODEL	SERIES	ENGINE	TRANS	YEAR FROM	YEAR TO	RADIATOR OPTION 1	PAGE	RADIATOR OPTION 2	PAGE	CONDENSER OPTION 1	CONDENSER OPTION 2	RECEIVER DRIER OPTION 1	RECEIVER DRIER OPTION 2
JEEP													
CHEROKEE	KJ	3.7L Petrol	Auto	09-01	03-08	JEE31136	257		257	CNX670		RDX588	
CHEROKEE	XJ	2.5L Turbo Diesel	Man	08-97	09-01	JEE31120	257		257	CNX851		RDX588	
CHEROKEE	XJ	4.0L Petrol	Auto	04-94	12-01	JEE31120	257	JEE31127	257	CNX670		RDX585	
GRAND CHEROKEE	WG	4.0L Petrol	Auto	01-01	06-05	JEE31138	258			CNX282			
GRAND CHEROKEE	WG	4.7L Petrol	Auto	01-01	06-05	JEE31140	257			CNX282		RDX587	
GRAND CHEROKEE	WJ	4.0L Petrol	Auto	06-99	01-01	JEE31125	257	JEE31138	258	CNX282			
GRAND CHEROKEE	WJ	4.7L Petrol	Auto	06-99	01-01	JEE31144	257			CNX282		RDX587	
GRAND CHEROKEE	ZG	4.0L Petrol	Auto	03-96	07-99	JEE31130	258	JEE31131	258			RDX586	
KIA													
CARENS	FC52	1.8L Petrol	Auto	07-00	10-02	KIA0001	259						
CARENS	FC52	1.8L Petrol	Man	07-00	10-02	R33CM	259						
CARNIVAL	KV	2.5L Petrol	Auto	09-99	10-03	KIA0003	259						
CARNIVAL	KV	2.5L Petrol	Man	09-99	10-03	KIA1003	260						
CARNIVAL	KVII	2.5L Petrol	Auto	10-03	12-06	KIA0003	259			CNX733			
CARNIVAL	KVII	2.5L Petrol	Man	10-03	08-06	KIA1003	260			CNX733			
CERATO	FE22	2.0L Petrol	Auto	07-04	12-08	KIA1153	260						
CERATO	FE22	2.0L Petrol	Man	07-04	12-08	KIA1153	260			CNX739			
CERATO	FE24	2.0L Petrol	Auto	04-06	12-08	KIA1153	260						
CERATO	FE24	2.0L Petrol	Man	04-06	12-08	KIA1153	260						
CERATO	LD	2.0L Petrol	Auto	01-07	01-09	KIA1153	260						
CERATO	LD	2.0L Petrol	Man	01-07	01-09	KIA1153	260						
CREDOS	G11	2.0L Petrol	Auto	05-98	05-01	KIA0013	260						
CREDOS	G11	2.0L Petrol	Man	05-98	05-01	KIA1699	260	KIA0013	260				

MODEL	SERIES	ENGINE	TRANS	YEAR FROM	YEAR TO	RADIATOR OPTION 1	PAGE	RADIATOR OPTION 2	PAGE	CONDENSER OPTION 1	CONDENSER OPTION 2	RECEIVER DRIER OPTION 1	RECEIVER DRIER OPTION 2
KIA (continued)													
MAGENTIS		2.4L Petrol	Auto	10-08		HYU0001	251						
MAGENTIS	MG	2.4L Petrol	Auto	09-06	10-09	HYU0001	251						
MAGENTIS	MG	2.7L Petrol	Auto	09-06	10-08	HYU0001	251			CNX161			
MENTOR	FA24	1.5L Petrol	Auto	11-96	04-99	KIA0004	261			CNX726			
MENTOR	FA24	1.5L Petrol	Man	11-96	04-99	KIA1004	261			CNX726			
MENTOR	FB22	1.5L Petrol	Auto	04-98	10-00	KIA0001	259	KIA0002	260	CNX725			
MENTOR	FB22	1.5L Petrol	Man	04-98	10-00	KIA1002	261			CNX725			
MENTOR	FB24	1.5L Petrol	Auto	04-98	10-00	KIA0001	259	KIA0002	260	CNX725			
MENTOR	FB24	1.8L Petrol	Auto	04-98	04-01	KIA0001	259	KIA0002	260	CNX725			
MENTOR	FB24	1.8L Petrol	Man	04-98	04-01	KIA1002	261			CNX725			
OPTIMA	GD22	2.5L Petrol	Auto	05-01	01-04	HYU30070	248			CNX732		RDX492	
OPTIMA	GD22	2.5L Petrol	Man	05-01	01-04	HYU30070	248			CNX732		RDX492	
OPTIMA	GD22	2.7L Petrol	Auto	04-04	01-07	HYU30070	248			CNX732		RDX492	
PREGIO	3VRS	2.7L Diesel	Man	07-02	07-04	KIA1007	262					RDX311	
PREGIO	CT	2.7L Diesel	Man	07-04	03-07	KIA1007	262						
RIO		1.5L Petrol	Auto	01-03	01-05	KIA0006	262			CNX731			
RIO		1.5L Petrol	Man	01-03	01-05	KIA1006	262			CNX731			
RIO	BC	1.5L Petrol	Auto	07-00	12-05	KIA0005	262			CNX731		RDX311	
RIO	BC	1.5L Petrol	Man	07-00	12-05	KIA1005	263			CNX731		RDX311	
RIO	JB	1.4L Petrol	Auto	03-07		HYU0034	244						
RIO	JB	1.6L Petrol	Auto	08-05		HYU0034	244			CNX722		RDX0040	
SHUMA	FB24	1.8L Petrol	Auto	04-00	05-02	KIA0001	259	KIA0002	260	CNX737		RDX476	
SHUMA	FB24	1.8L Petrol	Man	04-00	05-02	KIA1002	261			CNX737		RDX476	
SORENTO	BL	2.5L Turbo Diesel	Auto	08-07	12-09	KIA0011	263						

MODEL	SERIES	ENGINE	TRANS	YEAR FROM	YEAR TO	RADIATOR OPTION 1	PAGE	RADIATOR OPTION 2	PAGE	CONDENSER OPTION 1	CONDENSER OPTION 2	RECEIVER DRIER OPTION 1	RECEIVER DRIER OPTION 2
SORENTO	BL	3.5L Petrol	Auto	02-03	10-04	KIA1203	263		263	CNX167			
SORENTO	BL	3.5L Petrol	Man	10-03	03-07	KIA1203	263		263	CNX167			
SORENTO	EX	3.5L Petrol	Auto	10-04	08-07	KIA1203	263		263	CNX167			
SPECTRA	FB24	1.8L Petrol	Auto	05-01	11-04	KIA0001	259	KIA0002	260	CNX727		RDX476	
SPECTRA	FB24	1.8L Petrol	Man	05-01	11-04	KIA1002	261		261	CNX727		RDX476	
SPORTAGE	JA52	2.0L Petrol	Auto	04-00	07-03	KIA0012	264		264	CNX730		RDX461	
SPORTAGE	JA52	2.0L Petrol	Man	01-98	07-03	KIA1012	264		264	CNX730		RDX461	
SPORTAGE	JA55	2.0L Petrol	Auto	11-96	04-00	KIA0012	264		264	CNX730		RDX461	
SPORTAGE	JA55	2.0L Petrol	Man	11-96	04-00	KIA1012	264		264	CNX730		RDX461	
LAND ROVER													
RANGE ROVER		4.4L Petrol	Auto	01-07	09-09	ROV18321	265		265				
RANGE ROVER	L322	4.4L Petrol	Auto	08-02	01-06	ROV18321	265		265				
RANGE ROVER	VOGUE	4.4L Petrol	Auto	08-05		ROV18321	265		265				
75		2.5L Petrol	Man	03-01	07-04	ROV72211	334						
LEXUS													
ES300	MCV20R	3.0L Petrol	Auto	10-96	10-01	TOY60270	265	E32CA	265	CNX8110		RDX281	
ES300	MCV30R	3.0L Petrol	Auto	10-01	11-05	TOY60270	265	E32CA	265	CNX8110		RDX281	
ES300	VCV10R	3.0L Petrol	Auto	06-92	10-96	TOY60070	265	E70CA	265	CNX1580		RDX281	
GS300		3.0L Petrol	Auto	03-05		E71CA	265						
ISUZU													
GS300	JZS160R	3.0L Petrol	Auto	10-97	11-00	E71CA	265		265	CNX8400		RDX0040	
IS200	GXE10R	2.0L Petrol	Auto	03-99	11-05	E80CA	266		266	CNX0240		RDX0050	
IS200	GXE10R	2.0L Petrol	Man	03-99	11-05	E80CM	266		266	CNX0240		RDX0050	

MODEL	SERIES	ENGINE	TRANS	YEAR FROM	YEAR TO	RADIATOR OPTION 1	PAGE	RADIATOR OPTION 2	PAGE	CONDENSER OPTION 1	CONDENSER OPTION 2	RECEIVER DRIER OPTION 1	RECEIVER DRIER OPTION 2
ISUZU													
IS250	BK	2.5L Petrol	Auto	11-05		E116CM	266			CNX1122		RDX0040	
IS250	BK	2.5L Petrol	Man	11-05		E116CM	266			CNX1122		RDX0040	
IS300	JCE10R	3.0L Petrol	Auto	08-01	11-05	E81CA	266			CNX0240		RDX0050	
LS400	UCF10R	4.0L Petrol	Auto	01-90	11-97	E44CA	267						
LS400	UCF20R	4.0L Petrol	Auto	01-94	11-00	E44CA	267						
LS430	UCF30R	4.3L Petrol	Auto	09-03	05-08	E109CA	266			CNX8360		RDX0040	
LX470	UZJ100R	4.7L Petrol	Auto	04-98	09-02	TOY61260	266						
RX330	MCU38R	3.3L Petrol	Auto	04-03	02-06	E102CA	267	E120CA	267	CNX6380		RDX0040	
RX350	GGL15R	3.5L Petrol	Auto	09-09		E126CA	267						
RX350	GSU35R	3.5L Petrol	Auto	01-06	06-09	E126CA	267			CNX1271		RDX0070	
RX350	K31	3.5L Petrol	Auto	02-06	06-09	E126CA	267			CNX1271		RDX0070	
SC430		4.3L Petrol	Auto	10-01	09-05	E88CA	267			CNX3020			
SC430	N48	4.3L Petrol	Auto	09-05		E88CA	267						
MACK													
PREMIUM	320	11.1L Turbo Diesel	Man	01-03	01-08	MAC21781	268	MAC26481	267				
PREMIUM		6.2L Diesel	Man	01-98	01-03	MAC21781	268						
VISION		12.0L Turbo Diesel	Man	01-03	12-03	MAC53551	268						
MAZDA													
121		1.3L Petrol	Auto	10-96	12-02	M35CA	198	M36CA	199			RDX600	
121		1.3L Petrol	Man	02-93	12-02	M36CM	199	G8CM	198	CNX110		RDX182	RDX600
121		1.5L Petrol	Auto	01-94	10-96	M35CA	198	M36CA	199	CNX108		RDX182	
121		1.5L Petrol	Man	01-94	10-96	M36CM	199	G8CM	198	CNX108		RDX182	

MODEL	SERIES	ENGINE	TRANS	YEAR FROM	YEAR TO	RADIATOR OPTION 1	PAGE	RADIATOR OPTION 2	PAGE	CONDENSER OPTION 1	CONDENSER OPTION 2	RECEIVER DRIER OPTION 1	RECEIVER DRIER OPTION 2
323	2	1.6L Petrol	Auto	01-88	12-88	M14CA	203						
323		1.6L Petrol	Auto	10-85	10-87	M14CA	203			CNX006		RDY086	
323		1.6L Petrol	Auto	10-89	11-96	FOR40053	202	FOR40059	202	CNX007		RDY180	
323		1.6L Petrol	Auto	01-91	12-97	FOR40120	201						
323		1.6L Petrol	Man	10-85	09-88	M13CM	202			CNX006		RDY086	
323		1.6L Petrol	Man	10-89	12-97	FOR40055	202	FOR40057	201	CNX007		RDY180	
323	BF	1.6L Petrol	Auto	01-85	10-89	M14CA	203			CNX006		RDY086	
323	BF	1.6L Petrol	Man	01-85	10-89	M13CM	202			CNX006		RDY086	
323	BF	1.6L Turbo Petrol	Man	10-87	10-89	M13CM	202			CNX006		RDY086	
323	BG	1.8L Petrol	Auto	10-89	08-94	FOR40053	202	FOR40059	202	CNX007		RDY180	
323	BG	1.8L Petrol	Man	10-89	08-94	FOR40055	202	FOR40057	201	CNX007		RDY180	
323	SERIES 1	1.3L Petrol	Man	03-77	10-80	MAZ40051	203	MAZ40151	275			RDY086	
323	SERIES 1	1.4L Petrol	Man	03-77	03-82	MAZ40151	275						
323	SERIES 1	1.5L Petrol	Man	03-81	10-82	MAZ40051	203					RDY086	
323	SERIES 2	1.6L Petrol	Auto	01-86	09-87	M14CA	203			CNX006		RDY086	
323	SERIES 2	1.6L Petrol	Man	10-85	10-89	M13CM	202			CNX006		RDY086	
626	CB2	2.0L Petrol	Man	06-79	02-83	MAZ40100	278						
626	GC	2.0L Petrol	Man	01-83	10-87	M10CM	205					RDY025	
626	GD	2.2L Petrol	Auto	06-88	05-95	MAZ40103	277			CNX014		RDY089	
626	GD	2.2L Turbo Petrol	Auto	10-87	12-91	MAZ40103	277			CNX014		RDY089	
626	GD	2.2L Petrol	Man	06-88	05-95	MAZ40103	277			CNX014		RDY089	
626	GD	2.2L Turbo Petrol	Man	10-87	12-91	MAZ40103	277			CNX014		RDY089	
626	GE	2.0L Petrol	Auto	01-92	12-97	MAZ40120	277	MAZ40125	205	CNX102		RDY087	
626	GE	2.0L Petrol	Man	01-92	12-97	MAZ40125	205	MAZ81471	273	CNX102		RDY087	
626	GE	2.2L Petrol	Auto	04-95	01-98	MAZ40125	205			CNX105		RDY182	

MODEL	SERIES	ENGINE	TRANS	YEAR FROM	YEAR TO	RADIATOR OPTION 1	PAGE	RADIATOR OPTION 2	PAGE	CONDENSER OPTION 1	CONDENSER OPTION 2	RECEIVER DRIER OPTION 1	RECEIVER DRIER OPTION 2
MAZDA (continued)													
626	GE	2.2L Petrol	Man	04-95	01-98	MAZ40125	205			CNX105			RDX182
626	GE	2.5L Petrol	Auto	12-91	08-97	MAZ40130	205	MAZ40135	187	CNX102			RDX087
626	GE	2.5L Petrol	Man	12-91	08-97	MAZ40135	187			CNX102			RDX087
626	GF	2.0L Petrol	Auto	08-97	08-02	MAZ40120	277	MAZ40125	205	CNX105			RDX182
626	GF	2.0L Petrol	Man	08-97	08-02	MAZ40125	205	MAZ81471	273	CNX105			RDX182
929	HB	1.8L Petrol	Man	01-74	06-78	MAZ40200	278						
929	HC	3.0L Petrol	Auto	06-87	05-91	MAZ40201	278	MAZ40220	278				RDX089
929	HD	3.0L Petrol	Auto	01-90	12-96	MAZ40201	278	MAZ40220	278				
121 METRO		1.3L Petrol	Auto	03-00	12-02	M35CA	198	M36CA	199				
121 METRO		1.3L Petrol	Man	10-96	12-02	G10CM	199	G8CM	198				
121 METRO		1.5L Petrol	Auto	11-96	12-02	M35CA	198	M36CA	199				
121 METRO		1.5L Petrol	Man	11-96	12-02	G10CM	199	G8CM	198				
323 ASTINA	BA	1.8L Petrol	Auto	08-94	09-98	FOR40065	201	FOR40120	201	CNX008			RDX477
323 ASTINA	BA	1.8L Petrol	Man	08-94	09-98	M33CM	201	FOR40067	201	CNX008			RDX477
323 ASTINA	BA	2.0L Petrol	Auto	08-94	07-98	MAZ81471	273	MAZ40140	273	CNX012			RDX477
323 ASTINA	BA	2.0L Petrol	Man	08-94	07-98	MAZ1801	273	MAZ08031	272	CNX012			RDX477
323 ASTINA	BG	1.8L Petrol	Auto	10-89	08-94	FOR40059	202	MAZ40140	273	CNX007			RDX180
323 ASTINA	BG	1.8L Petrol	Man	10-89	08-94	MAZ40052	273			CNX007			RDX180
323 ASTINA	BJ	1.6L Petrol	Auto	01-98	06-02	MAZ40142	200			CNX759			RDX182
323 ASTINA	BJ	1.6L Petrol	Man	01-98	06-02	MAZ40144	201	FOR40067	201	CNX759			RDX182
323 ASTINA	BJ	1.8L Petrol	Auto	09-98	03-04	MAZ40142	200			CNX759			RDX182
323 ASTINA	BJ	1.8L Petrol	Man	09-98	03-04	MAZ40144	201	FOR40067	201	CNX759			RDX182
323 ASTINA	BJ	2.0L Petrol	Auto	02-01	03-04	MAZ08031	272						RDX190
323 ASTINA	BJ	2.0L Petrol	Man	02-01	03-04	MAZ40142	200			CNX105			RDX190

MODEL	SERIES	ENGINE	TRANS	YEAR FROM	YEAR TO	RADIATOR OPTION 1	PAGE	RADIATOR OPTION 2	PAGE	CONDENSER OPTION 1	CONDENSER OPTION 2	RECEIVER DRIER OPTION 1	RECEIVER DRIER OPTION 2
323 PROTEGE	BA	1.6L Petrol	Auto	08-94	09-98	FOR40065	201	FOR40120	201	CNX007		RDX182	
323 PROTEGE	BA	1.6L Petrol	Man	08-94	09-98	MAZ40144	201	FOR40067	201	CNX007		RDX182	
323 PROTEGE	BA	1.8L Petrol	Auto	08-94	09-98	FOR40065	201	FOR40120	201	CNX012		RDX477	
323 PROTEGE	BA	1.8L Petrol	Man	08-94	09-98	MAZ40144	201			CNX012		RDX477	
323 PROTEGE	BJ	1.6L Petrol	Auto	01-98	06-02	FOR40065	201	FOR40120	201	CNX008		RDX182	
323 PROTEGE	BJ	1.6L Petrol	Man	01-98	06-02	MAZ40144	201	FOR40067	201	CNX008		RDX182	
323 PROTEGE	BJ	1.8L Petrol	Auto	09-98	03-04	FOR40065	201	FOR40120	201	CNX759		RDX182	
323 PROTEGE	BJ	1.8L Petrol	Man	09-98	03-04	MAZ40144	201	FOR40067	201	CNX759		RDX182	
323 PROTEGE	BJ	2.0L Petrol	Auto	08-02	03-04	FOR40065	201	FOR40120	201	CNX759		RDX190	
323 PROTEGE	BJ	2.0L Petrol	Man	04-02	03-04	FOR40067	201			CNX103		RDX190	
B SERIES	B1600	1.6L Petrol	Man	07-71	10-77	MAZ40420	191						
B SERIES	B2000	2.0L Petrol	Man	06-85	11-91	MAZ40401	281					RDX086	
B SERIES	B2200	2.2L Petrol	Auto	01-91	12-91	MAZ40401	281						
B SERIES	B2200	2.2L Diesel	Man	06-85	11-91	MAZ40401	281					RDX086	
B SERIES	B2200	2.2L Petrol	Man	06-85	11-91	MAZ40401	281					RDX086	
B SERIES	B2600	2.6L Petrol	Man	03-87	01-90	MAZ40400	190	MAZ40430	190			RDX086	
BOUNTY (NZ)		2.5L Turbo Diesel	Auto	01-99	12-05	FOR40315	189						
BOUNTY (NZ)		2.5L Turbo Diesel	Auto	01-99	12-05	FOR40315	189						
BOUNTY (NZ)		2.5L Turbo Diesel	Auto	01-99	12-06	FOR40318	188						
BRAVO	B2200	2.2L Petrol	Man	01-92	01-94	MAZ40400	190						
BRAVO	B2200	2.2L Diesel	Man	11-91	03-96	MAZ40400	190						
BRAVO	B2500	2.5L Turbo Diesel	Auto	01-06	11-06	FOR40315	189	FOR40318	188				
BRAVO	B2500	2.5L Turbo Diesel	Man	02-99	01-03	FOR40316	189	FOR40319	189				
BRAVO	B2500	2.5L Diesel	Man	05-96	02-99	FOR40316	189	FOR40319	189	CNX008			
BRAVO	B2600			03-88	01-90	MAZ40430	190						
BRAVO	B2600	2.6L Petrol	Auto	01-90	07-06	FOR40315	189	FOR40318	188	CNX008		RDX086	

MODEL	SERIES	ENGINE	TRANS	YEAR FROM	YEAR TO	RADIATOR OPTION 1	PAGE	RADIATOR OPTION 2	PAGE	CONDENSER OPTION 1	CONDENSER OPTION 2	RECEIVER DRIER OPTION 1	RECEIVER DRIER OPTION 2
MAZDA (continued)													
BRAVO	B2600	2.6L Petrol	Man	01-90	03-96	FOR40319	189	FOR43022	190	CNX008		RDX086	RDX022
BRAVO	B2600	2.6L Petrol	Man	03-87	01-90	MAZ40430	190					RDX086	
BT50	B2500	2.5L Turbo Diesel	Man	11-06		FOR40319	189					RDX192	
BT50	B3000	3.0L Turbo Diesel	Man	11-06		FOR40319	189			CNX409		RDX191	
CAPELLA (NZ)		2.0L Petrol	Auto	01-97	12-02	MAZ40125	205						
CX7		2.5L Petrol	Auto	10-09		MAZ1719	281	G24CA	281				
CX7	ER	2.3L Turbo Petrol	Auto	11-06		MAZ1719	281	G24CA	281	CNX1480			
CX9	TB10A4	3.7L Petrol	Auto	12-07		MAZ1088	282	G25CA	282	CNX3521		RDX0070	
E SERIES	E1800	1.8L Petrol	Man	01-03	05-06	M43CM	190	FOR40210	191	CNX410		RDX5810	
E SERIES	E1800	1.8L Petrol	Man	02-84	12-96	FOR40210	191			CNX401		RDX025	
E SERIES	E2000	2.0L Petrol	Man	01-95	12-02	M40CM	191						
E SERIES	E2000	2.0L Petrol	Man	10-99	01-03	M43CM	190					RDX025	
E SERIES	E2000	2.0L Petrol	Man	11-01	05-07	M40CM	191	M43CM	190	CNX401		RDX025	
E SERIES	E2200	2.2L Diesel	Man	01-82	01-84	FOR40200	191			CNX401		RDX022	
E SERIES	E2500	2.5L Diesel	Man	08-97	05-03	G21CM	191						
EUNOS	500	2.0L Petrol	Auto	09-96	11-99	MAZ40135	187						
EUNOS	500	2.0L Petrol	Man	06-94	02-00	MAZ40135	187					RDX601	
EUNOS	800	2.3L Petrol	Auto	03-94	10-00	MAZ40135	187					RDX182	
EUNOS	800	2.5L Petrol	Auto	03-94	09-96	MAZ40135	187						
EUNOS	30X	1.8L Petrol	Auto	11-92	12-97	MAZ40135	187					RDX182	
EUNOS	30X	1.8L Petrol	Man	11-92	12-97	MAZ40135	187					RDX182	
EUNOS 30X		1.8L Petrol	Auto	11-96	04-98	MAZ40135	187						
EUNOS 30X		1.8L Petrol	Man	11-96	04-98	MAZ40135	187						
EUNOS 500		2.0L Petrol	Auto	11-96	01-00	MAZ40135	187						

MODEL	SERIES	ENGINE	TRANS	YEAR FROM	YEAR TO	RADIATOR OPTION 1	PAGE	RADIATOR OPTION 2	PAGE	CONDENSER OPTION 1	CONDENSER OPTION 2	RECEIVER DRIER OPTION 1	RECEIVER DRIER OPTION 2
FAMILIA (NZ)		1.3L Petrol	Auto	01-89	12-96	FOR40059	202						
FAMILIA (NZ)		1.3L Petrol	Auto	01-89	12-96	FOR40059	202						
FAMILIA (NZ)		1.5L Petrol	Auto	01-94	12-98	FOR40120	201						
FAMILIA (NZ)		1.5L Petrol	Auto	01-89	12-95	FOR40059	202						
FAMILIA (NZ)		1.5L Petrol	Auto	01-89	12-95	FOR40059	202						
FAMILIA (NZ)		1.5L Petrol	Auto	01-98	12-03	MAZ40142	200						
FAMILIA (NZ)		1.5L Petrol	Auto	01-89	12-90	FOR40059	202						
FAMILIA (NZ)		1.5L Petrol	Auto	01-89	12-90	FOR40059	202						
FAMILIA (NZ)		1.5L Petrol	Auto	01-89	12-94	FOR40059	202						
FAMILIA (NZ)		1.5L Petrol	Auto	01-89	12-94	FOR40059	202						
FAMILIA (NZ)		1.5L Petrol	Auto	01-89	12-94	FOR40059	202						
FAMILIA (NZ)		1.5L Petrol	Auto	01-89	12-94	FOR40059	202						
FAMILIA (NZ)		1.5L Petrol	Auto	01-89	12-94	FOR40059	202						
FAMILIA (NZ)		1.5L Petrol	Auto	01-89	12-94	FOR40059	202						
FAMILIA (NZ)		1.5L Petrol	Auto	01-89	12-94	FOR40059	202						
FAMILIA (NZ)		1.5L Petrol	Man	01-94	12-99	FOR40120	201						
FAMILIA (NZ)		1.5L Petrol	Man	01-89	12-95	FOR40057	201						
LANTIS		1.8L Petrol	Auto	01-93	12-97	FOR40120	201						
MAZDA2	DE	1.5L Petrol	Auto	09-07		G26CA	270	MAZ40162	271	CNX114			
MAZDA2	DE	1.5L Petrol	Man	09-07		G26CM	270	MAZ40163	271	CNX114			
MAZDA2	DY	1.5L Petrol	Auto	12-02	09-07	G17CA	271			CNX114			
MAZDA2	DY	1.5L Petrol	Man	12-02	09-07	G18CM	271			CNX114			
MAZDA2	MAXX	1.5L Petrol	Auto	04-08		G26CA	270	MAZ40162	271				
MAZDA2	MAXX	1.5L Petrol	Man	04-08		G26CM	270	MAZ40163	271				
MAZDA2	NEO	1.5L Petrol	Auto	04-08		G26CA	270	MAZ40162	271				
MAZDA2	NEO	1.5L Petrol	Man	04-08		G26CM	270	MAZ40163	271				
MAZDA3	BK	2.0L Turbo Diesel	Man	08-07	04-10	MAZ40160	271			CNX112		RDx280	
MAZDA3	MAXX SPORT	2.0L Petrol	Auto	01-04	07-06	MAZ40160	271			CNX112		RDx280	

MODEL	SERIES	ENGINE	TRANS	YEAR FROM	YEAR TO	RADIATOR OPTION 1	PAGE	RADIATOR OPTION 2	PAGE	CONDENSER OPTION 1	CONDENSER OPTION 2	RECEIVER DRIER OPTION 1	RECEIVER DRIER OPTION 2
MAZDA (continued)													
MAZDA3	MAXX SPORT	2.0L Petrol	Auto	07-06	04-10	MAZ40160	271			CNX112		RDX280	
MAZDA3	MAXX SPORT	2.0L Petrol	Man	01-04	07-06	MAZ40160	271			CNX112		RDX280	
MAZDA3	MAXX SPORT	2.0L Petrol	Man	07-06	04-10	MAZ40160	271			CNX112		RDX280	
MAZDA3	MPS	2.3L Turbo Petrol	Man	07-06		MAZ40160	271			CNX112		RDX280	
MAZDA3	MPS SPORT	2.3L Turbo Petrol	Man	07-06	12-09	MAZ40160	271			CNX112		RDX280	
MAZDA3	NEO	2.0L Petrol	Man	07-06	04-10	MAZ40160	271			CNX112		RDX280	
MAZDA3	NEO-MAXX	2.0L Petrol	Auto	01-04	07-06	MAZ40160	271			CNX112		RDX280	
MAZDA3	NEO-MAXX	2.0L Petrol	Auto	07-06	04-10	MAZ40160	271			CNX112		RDX280	
MAZDA3	NEO-MAXX	2.0L Petrol	Man	01-04	07-06	MAZ40160	271			CNX112		RDX280	
MAZDA3	NEO-MAXX	2.0L Petrol	Man	07-06	04-10	MAZ40160	271			CNX112		RDX280	
MAZDA3	SP23	2.3L Petrol	Auto	01-04	07-06	MAZ40160	271			CNX112		RDX280	
MAZDA3	SP23	2.3L Petrol	Auto	07-06	04-10	MAZ40160	271			CNX112		RDX280	
MAZDA3	SP23	2.3L Petrol	Man	01-04	07-06	MAZ40160	271			CNX112		RDX280	
MAZDA6	GG	2.0L Turbo Diesel	Man	10-06	02-08	MAZ69671	276						
MAZDA6	GG	2.3L Petrol	Auto	08-02	08-05	MAZ1858	276	MAZ54251	276	CNX116		RDXX040	
MAZDA6	GG	2.3L Petrol	Man	08-02	08-05	MAZ1829	276	MAZ69671	276	CNX116		RDXX040	
MAZDA6	GG	2.3L Petrol	Man	08-05	02-08	G30CM	276	MAZ69671	276	CNX116		RDXX040	
MAZDA6	GG	2.3L Turbo Petrol	Man	10-05	02-08	G30CM	276	MAZ69671	276				
MAZDA6	GH	2.5L Petrol	Auto	01-09		MAZ1249	275	G28CA	275				
MAZDA6	GH	2.5L Petrol	Man	01-09		MAZ1249	275			CNX116			
MAZDA6	GY	2.0L Turbo Diesel	Man	04-07	02-08	MAZ69671	276						
MAZDA6	GY	2.3L Petrol	Auto	08-02	08-05	MAZ1858	276	MAZ54251	276	CNX116		RDXX040	
MPV	D	2.5L Petrol	Auto	08-99	06-02	MAZ40220	278	G19CA	284	CNX0950		RDXX040	
MPV	E	3.0L Petrol	Auto	06-02	11-03	MAZ40220	278	G19CA	284	CNX4410		RDXX040	
MPV	F	3.0L Petrol	Auto	01-02	11-06	MAZ40220	278	G19CA	284	CNX4410		RDXX040	

MODEL	SERIES	ENGINE	TRANS	YEAR FROM	YEAR TO	RADIATOR OPTION 1	PAGE	RADIATOR OPTION 2	PAGE	CONDENSER OPTION 1	CONDENSER OPTION 2	RECEIVER DRIER OPTION 1	RECEIVER DRIER OPTION 2
MPV	SERIES C	3.0L Petrol	Auto	09-93	08-99	MAZ40220	278	G19CA	284	CNX113		RDX281	
MX-5	NA	1.6L Petrol	Man	10-89	11-93	MAZ40156	285			CNX2070		RDX087	
MX-5	NA	1.8L Petrol	Auto	11-93	04-98	MAZ40155	285			CNX2070		RDX087	
MX-5	NA	1.8L Petrol	Man	11-93	04-98	MAZ40156	285			CNX2070		RDX087	
MX-5	NB	1.8L Petrol	Auto	03-98	09-05	MAZ40155	285	MAZ40157	285				
MX-5	NB	1.8L Petrol	Man	02-99	09-05	MAZ40156	285	MAZ40158	285				
MX-5	SP	1.8L Turbo Petrol	Man	01-02	11-02	MAZ40158	285						
MX-6	GD	2.2L Turbo Petrol	Auto	10-87	09-91	MAZ40103	277			CNX014		RDX089	
MX-6	GD	2.2L Turbo Petrol	Man	10-87	09-91	MAZ40103	277			CNX014		RDX089	
MX-6	GD1022	2.2L Turbo Petrol	Auto	01-91	12-91	MAZ40103	277						
MX-6	GD1022	2.2L Turbo Petrol	Man	01-91	12-91	MAZ40103	277						
MX-6	GE	2.5L Petrol	Auto	11-91	12-97	MAZ40135	187			CNX102		RDX087	
MX-6	GE	2.5L Petrol	Man	11-91	12-97	MAZ40135	187			CNX102		RDX087	
MX-6	GE10L1	2.5L Petrol	Auto	01-91	12-92	MAZ40103	277						
PROCEED		2.6L Petrol	Auto	01-91	12-96	FOR43020	189						
RX-7	FC1031	1.3L Petrol	Auto	02-86	01-88	MAZ40300	285						
RX-7	FC1031	1.3L Turbo Petrol	Man	01-86	12-86	MAZ40300	285						
RX-7	FC1031	1.3L Petrol	Man	01-87	01-90	MAZ40300	285						
RX-7	FC1032	1.3L Petrol	Auto	01-90	01-92	MAZ40300	285						
RX-7	FC1032	1.3L Petrol	Man	01-90	01-91	MAZ40300	285						
RX-7	FC1032	1.3L Turbo Petrol	Man	01-90	01-92	MAZ40300	285						
RX-7	SERIES 4	1.3L Petrol	Auto	06-86	02-92	MAZ40300	285					RDX086	
RX-7	SERIES 4	1.3L Petrol	Man	06-86	02-92	MAZ40300	285					RDX086	
RX-8		1.3L Petrol	Auto	07-03	02-09	MAZ40180	286						
RX-8		1.3L Petrol	Man	07-03		MAZ40180	286			CNX8440		RDX0040	

MODEL	SERIES	ENGINE	TRANS	YEAR FROM	YEAR TO	RADIATOR OPTION 1	PAGE	RADIATOR OPTION 2	PAGE	CONDENSER OPTION 1	CONDENSER OPTION 2	RECEIVER DRIER OPTION 1	RECEIVER DRIER OPTION 2
MAZDA (continued)													
TRIBUTE		2.3L Petrol	Auto	01-04	12-08	MAZ1867	192						
TRIBUTE	CU8Y	2.3L Petrol	Auto	01-04	12-07	MAZ1867	192						
TRIBUTE	EP	2.0L Petrol	Man	02-01	01-04	MAZ2436	286			CNX115		RD183	
TRIBUTE	EP	3.0L Petrol	Auto	01-04	06-06	MAZ1866	192			CNX115		RD183	
TRIBUTE	EPEW	3.0L Petrol	Auto	02-01	01-04	MAZ1866	192		192	CNX115		RD183	
TRIBUTE	EPEW	3.0L Petrol	Man	01-00		MAZ1866	192						
MERCEDES-BENZ													
180E	W201	1.8L Petrol	Auto	10-91	02-94	MER12291	292	MER11311	289				RD1206
180E	W201	1.8L Petrol	Man	10-91	08-93	MER12291	292	MER11311	289				RD1206
190D	W201	2.5L Diesel	Auto	01-86	12-89	MER12311	292						RD1206
190E	W201	1.8L Petrol	Auto	09-90	02-94	MER12291	292	MER11311	289	CNX596			RD1206
190E	W201	1.8L Petrol	Man	09-90	02-94	MER12291	292	MER11311	289	CNX596			RD1206
190E	W201	2.0L Petrol	Auto	12-84	02-95	MER12291	292	MER11311	289				RD1206
190E	W201	2.0L Petrol	Auto	01-84	12-92	MER12291	292						
190E	W201	2.0L Petrol	Man	12-84	08-93	MER12291	292	MER11311	289				
190E	W201	2.3L Petrol	Auto	09-90	10-92	MER12291	292	MER11371	292	CNX596			RD1206
190E	W201	2.3L Petrol	Man	09-90	10-92	MER12291	292	MER11371	292	CNX596			RD1206
190E	W201	2.6L Petrol	Auto	07-87	02-92	MER12531	292	MER14011	293				RD1203
230E	W123	2.3L Petrol	Auto	07-81	12-85	MER10531	290			CNX583			RD1203
230E	W124	2.3L Petrol	Auto	02-86	09-93	MER12421	289	MER11311	289				RD1203
230GE	W124	2.3L Petrol	Man	05-86	12-89	MER12421	289	MER11311	289				
240D	W123	2.4L Diesel	Auto	01-74	02-86	MER10531	290			CNX583			RD1202
240D	W123	2.4L Diesel	Man	01-74	02-86	MER10531	290			CNX583			RD1202

MODEL	SERIES	ENGINE	TRANS	YEAR FROM	YEAR TO	RADIATOR OPTION 1	PAGE	RADIATOR OPTION 2	PAGE	CONDENSER OPTION 1	CONDENSER OPTION 2	RECEIVER DRIER OPTION 1	RECEIVER DRIER OPTION 2
260E	W124	2.6L Petrol	Auto	08-88	03-91	MER12421	289		289			RDX203	
280E	W123	2.8L Petrol	Auto	11-76	02-86	MER10531	290		290	CNX583		RDX202	
280E	W123	2.8L Petrol	Man	11-76	02-86	MER10531	290		290	CNX583		RDX202	
280SE	W126	2.7L Petrol	Auto	02-81	04-86	MER10531	290	MER10501	290			RDX204	
280SEL	W126	2.8L Petrol	Auto	01-81	12-81	MER10531	290		290				
300D	W123	3.0L Diesel	Auto	09-79	02-86	MER10531	290		290	CNX583		RDX202	RDX203
300D	W123	3.0L Diesel	Man	11-76	09-79	MER10531	290		290	CNX583		RDX202	
300D	W124	3.0L Diesel	Auto	01-87	12-88	MER11101	289	MER12461	289			RDX203	
300D	W124	3.0L Diesel	Auto	02-86	09-93	MER11101	289	MER12461	289			RDX203	
300E	W124	2.6L Petrol	Auto	03-86	09-93	MER12421	289		289			RDX203	
300E	W124	2.8L Petrol	Auto	02-93	09-93	MER12421	289		289			RDX203	
300E	W124	3.0L Petrol	Auto	03-86	09-93	MER12421	289		289	CNX792		RDX203	RDX204
300SE	W126	3.0L Petrol	Auto	04-86	09-93	MER13291	290		290	CNX792		RDX204	RDX217
300SE	W140	3.2L Petrol	Auto	03-92	09-93	MER11521	291	MER12201	290			RDX213	
300SE-SEL	W126	3.0L Petrol	Auto	04-86	09-93	MER13291	290		290	CNX588			
300SE-SEL	W126	3.0L Petrol	Man	04-86	09-93	MER13291	290		290	CNX588			
300SEL	W126	3.0L Petrol	Auto	04-87	03-93	MER13291	290		290	CNX792		RDX204	RDX217
320E	W124	3.2L Petrol	Auto	02-93	09-93	MER12421	289		289	CNX780		RDX202	
380SE	W126	3.8L Petrol	Auto	08-83	04-86	MER12524	290		290	CNX792		RDX205	RDX217
380SEC	C126	3.8L Petrol	Auto	02-82	04-86	MER12524	290		290	CNX792		RDX205	RDX217
380SEL	W126	3.8L Petrol	Auto	02-81	04-86	MER12524	290		290	CNX792		RDX205	RDX217
400SE	W140	4.2L Petrol	Auto	03-92	09-93	MER11171	291		291			RDX213	
400SEL	W140	4.2L Petrol	Auto	03-92	09-93	MER11171	291		291			RDX213	
450SEL	W116	6.8L Petrol	Auto	07-73	02-81	MER11181	288		288			RDX201	

MODEL	SERIES	ENGINE	TRANS	YEAR FROM	YEAR TO	RADIATOR OPTION 1	PAGE	RADIATOR OPTION 2	PAGE	CONDENSER OPTION 1	CONDENSER OPTION 2	RECEIVER DRIER OPTION 1	RECEIVER DRIER OPTION 2
MERCEDES-BENZ (continued)													
500SEL	W140	5.0L Petrol	Auto	03-92	09-93	MER11181	288						RDX213
500SL	R129	5.0L Petrol	Auto	05-90	09-93	MER11181	288						
A140	W168	1.4L Petrol	Auto	02-00	07-01	MER13041	291	MER13051	291	CNX598			RDX246
A140	W168	1.4L Petrol	Man	02-00	07-01	MER13041	291	MER13051	291	CNX598			RDX246
A150	W169	1.5L Petrol	Man	04-05	07-07	MER30561	291	MER21021	292	CNX598			
A160	W168	1.6L Petrol	Auto	10-98	04-05	MER13041	291	MER13051	291	CNX598			RDX218
A160	W168	1.6L Petrol	Man	10-98	04-05	MER13041	291	MER13051	291	CNX598			RDX218
A170	W169	1.7L Petrol	Auto	04-05	12-09	MER30561	291	MER21031	292	CNX598			
A170	W169	1.7L Petrol	Man	04-05	12-09	MER30561	291	MER21021	292	CNX598			
A180	W169	1.7L Petrol	Auto	07-09	12-09	MER30561	291	MER21031	292	CNX812			RDX677
A180	W169	1.7L Petrol	Man	07-09	12-09	MER30561	291	MER21021	292	CNX812			RDX677
A180CDI	W169	2.0L Turbo Diesel	Auto	10-08	12-09	MER30561	291			CNX812			RDX677
A180CDI	W169	2.0L Turbo Diesel	Man	10-08	12-09	MER30561	291			CNX812			RDX677
A190	W168	1.9L Petrol	Auto	09-99	04-05	MER13041	291	MER13051	291	CNX598			RDX218
A190	W168	1.9L Petrol	Man	09-99	04-05	MER13041	291	MER13051	291	CNX598			RDX218
A200	W169	2.0L Petrol	Auto	04-05	12-09	MER30561	291	MER21031	292	CNX598			RDX246
A200	W169	2.0L Turbo Petrol	Auto	10-05	12-09	MER30561	291			CNX598			RDX246
A200	W169	2.0L Turbo Petrol	Man	01-05	12-09	MER30561	291			CNX598			RDX246
A200	W169	2.0L Petrol	Man	04-05	12-09	MER30561	291			CNX598			RDX246
ACTROS	2643	11.9L Turbo Diesel	Man	01-01	01-03	MER21231	287	MER21211	286	CNX634			RDX678
ACTROS	1840LS	11.9L Turbo Diesel	Man	09-99	01-03	MER21231	287	MER21211	286	CNX634			RDX678
ACTROS	1841LS	11.9L Turbo Diesel	Man	01-03	12-03	MER21491	286			CNX634			RDX678
ACTROS	2632-51	11.9L Turbo Diesel	Man	01-05	12-05	MER21491	286			CNX634			RDX678
ACTROS	2632K-33	11.9L Turbo Diesel	Man	01-05	12-05	MER21491	286			CNX634			RDX678

MODEL	SERIES	ENGINE	TRANS	YEAR FROM	YEAR TO	RADIATOR OPTION 1	PAGE	RADIATOR OPTION 2	PAGE	CONDENSER OPTION 1	CONDENSER OPTION 2	RECEIVER DRIER OPTION 1	RECEIVER DRIER OPTION 2
ACTROS	2632L-48	11.9L Turbo Diesel	Man	01-05	12-05	MER21491	286			CNX634		RDx678	
ACTROS	2640L	11.9L Turbo Diesel	Man	09-99	01-03	MER21231	287	MER21211	286	CNX634		RDx678	
ACTROS	2640LS	11.9L Turbo Diesel	Man	01-98	12-98	MER21231	287	MER21211	286	CNX634		RDx678	
ACTROS	2641LS-33	11.9L Turbo Diesel	Man	01-03	12-03	MER21491	286			CNX634		RDx678	
ACTROS	2643L	11.9L Turbo Diesel	Man	01-01	01-03	MER21231	287	MER21211	286	CNX634		RDx678	
ACTROS	2643LS	11.9L Turbo Diesel	Man	09-99	01-03	MER21231	287	MER21211	286	CNX634		RDx678	
ACTROS	2643S	Turbo Diesel	Man	11-97	01-99	MER21231	287	MER21211	286	CNX634		RDx678	
ACTROS	2644LS-33	11.9L Turbo Diesel	Man	01-03	01-06	MER21491	286			CNX634		RDx678	
ACTROS	2646LS-29	11.9L Turbo Diesel	Man	01-05	12-05	MER21491	286					RDx678	
ACTROS	2646LS-33	11.9L Turbo Diesel	Man	01-05	12-05	MER21491	286			CNX634		RDx678	
ACTROS	2648L	11.9L Turbo Diesel	Man	01-00	12-00	MER21231	287	MER21211	286	CNX634		RDx678	
ACTROS	2648L	15.9L Turbo Diesel	Man	01-01	01-03	MER21231	287	MER21211	286	CNX634		RDx678	
ACTROS	2648LS	11.9L Turbo Diesel	Man	01-00	12-00	MER21231	287	MER21211	286	CNX634		RDx678	
ACTROS	2648LS	15.9L Turbo Diesel	Man	09-99	01-03	MER21231	287	MER21211	286	CNX634		RDx678	
ACTROS	2648S	Turbo Diesel	Man	11-97	01-99	MER21231	287	MER21211	286	CNX634		RDx678	
ACTROS	2650LS-33	15.9L Diesel	Man	01-04	01-06	MER21491	286			CNX634		RDx678	
ACTROS	2650S-33	15.9L Diesel	Man	01-05	12-05	MER21491	286			CNX634		RDx678	
ACTROS	3236-54	11.9L Turbo Diesel	Man	01-03	12-04	MER21491	286			CNX634		RDx678	
ACTROS	3240-54	11.9L Turbo Diesel	Man	09-99	01-03	MER21231	287	MER21211	286	CNX634		RDx678	
ACTROS	3241-54	11.9L Turbo Diesel	Man	01-03	01-06	MER21491	286			CNX634		RDx678	
ACTROS	3243-54	11.9L Turbo Diesel	Man	01-00	01-03	MER21231	287	MER21211	286	CNX634		RDx678	
ACTROS	3244-54	11.9L Turbo Diesel	Man	01-03	12-04	MER21491	286			CNX634		RDx678	
ACTROS	3341AS-36	11.9L Turbo Diesel	Man	01-05	12-05	MER21491	286			CNX634		RDx678	
ACTROS	4141AK-48	11.9L Turbo Diesel	Man	01-05	12-05	MER21491	286			CNX634		RDx678	
ACTROS	4141B-51	11.9L Turbo Diesel	Man	01-05	12-05	MER21491	286			CNX634		RDx678	
ATEGO	1223-L54	6.4L Turbo Diesel	Man	01-01	12-04	MER58021	287	MER58031	287				

MODEL	SERIES	ENGINE	TRANS	YEAR FROM	YEAR TO	RADIATOR OPTION 1	PAGE	RADIATOR OPTION 2	PAGE	CONDENSER OPTION 1	CONDENSER OPTION 2	RECEIVER DRIER OPTION 1	RECEIVER DRIER OPTION 2
MERCEDES-BENZ (continued)													
ATEGO	1228-L54	6.4L Turbo Diesel	Man	01-03	12-04	MER58021	287	MER58031	287				
ATEGO	1528LS-36	6.4L Turbo Diesel	Man	01-05	12-08	MER58021	287	MER58031	287				
ATEGO	1623-L54	6.4L Turbo Diesel	Man	01-01	12-04	MER58021	287	MER58031	287				
ATEGO	1628-L54	6.4L Turbo Diesel	Man	01-01	12-04	MER58021	287	MER58031	287				
ATEGO	1628AF-39	6.4L Turbo Diesel	Man	01-05	12-08	MER58021	287	MER58031	287				
ATEGO	1628LF-42 FS	6.4L Turbo Diesel	Man	01-05	12-08	MER58021	287	MER58031	287				
ATEGO	2323-L54	6.4L Turbo Diesel	Man	01-03	12-08	MER58021	287	MER58031	287				
ATEGO	2328-L54	6.4L Turbo Diesel	Man	01-03	12-04	MER58021	287	MER58031	287				
B180	W245	1.7L Petrol	Auto	01-10		MER30561	291	MER21031	292	CNX812		RDX676	RDX677
B180	W245	1.7L Petrol	Man	01-10		MER30561	291	MER21021	292	CNX812		RDX676	RDX677
B180	W245	2.0L Turbo Diesel	Auto	02-06		MER30561	291			CNX812		RDX676	RDX677
B180	W245	2.0L Turbo Diesel	Man	02-06	07-07	MER30561	291			CNX812		RDX676	RDX677
B180	W245	2.0L Turbo Diesel	Man	07-07		MER30561	291	MER21021	292	CNX812		RDX676	RDX677
B180 CDI	W245	2.0L Turbo Diesel	Man	05-06		MER30561	291			CNX812		RDX676	RDX677
B200	W169	2.0L Turbo Petrol	Man	10-05	01-07	MER30561	291			CNX812		RDX676	RDX677
B200	W245	2.0L Petrol	Auto	10-05		MER30561	291	MER21031	292	CNX812		RDX676	RDX677
B200	W245	2.0L Petrol	Man	10-05		MER30561	291			CNX812		RDX676	RDX677
B200T	W245	2.0L Turbo Petrol	Auto	10-05		MER30561	291			CNX812		RDX676	RDX677
B200T	W245	2.0L Turbo Petrol	Man	10-05		MER30561	291			CNX812		RDX676	RDX677
C180	W202	1.8L Petrol	Auto	01-95	11-00	MER11191	293	MER12021	293	CNX622		RDX217	RDX045
C180	W202	1.8L Petrol	Man	02-94	11-00	MER12021	293			CNX622		RDX217	RDX045
C180	W203	1.8L Petrol	Auto	10-02	09-04	MER14331	293			CNX796			
C180	W203	2.0L Petrol	Auto	11-00	10-02	MER14331	293			CNX622		RDX217	RDX045
C180	W203	2.0L Petrol	Man	11-00	10-02	MER14331	293			CNX622		RDX217	RDX045

MODEL	SERIES	ENGINE	TRANS	YEAR FROM	YEAR TO	RADIATOR OPTION 1	PAGE	RADIATOR OPTION 2	PAGE	CONDENSER OPTION 1	CONDENSER OPTION 2	RECEIVER DRIER OPTION 1	RECEIVER DRIER OPTION 2
C180 KOMPRESSOR	W203	1.8L Petrol	Man	10-02	09-04	MER14331	293						
C180K	CL203	1.8L Petrol	Auto	01-02	04-08	MER14331	293						
C180K	CL203	1.8L Petrol	Man	01-02	04-08	MER14331	293						
C180K	W203	1.8L Petrol	Auto	01-02	08-07	MER14331	293			CNX796			
C180K	W203	1.8L Petrol	Man	01-02	08-07	MER14331	293			CNX796			
C200	W202	2.0L Petrol	Auto	11-96	11-00	MER11191	293	MER12021	293	CNX622		RDx217	RDx045
C200	W202	2.0L Petrol	Man	11-96	11-00	MER12201	290	MER11251	293	CNX622		RDx217	RDx045
C200 KOMPRESSOR	W203	2.0L Petrol	Auto	11-00	01-03	MER14331	293			CNX622		RDx217	
C200 KOMPRESSOR	W203	2.0L Petrol	Man	11-00	10-02	MER14331	293			CNX622		RDx217	RDx045
C200K	W203	1.8L Petrol	Auto	10-02	08-07	MER14331	293			CNX796			
C200K	W203	1.8L Petrol	Man	10-02	08-07	MER14331	293			CNX796			
C220	W202	2.2L Petrol	Auto	02-94	11-96	MER11191	293	MER12021	293	CNX622		RDx217	RDx045
C230	W202	2.3L Petrol	Auto	11-96	09-97	MER12021	293	MER11251	293	CNX622		RDx217	RDx045
C230	W203	2.5L Petrol	Auto	09-04	08-07	MER14331	293			CNX796			
C240	W202	2.4L Petrol	Auto	09-97	11-00	MER11191	293	MER12021	293	CNX622		RDx217	RDx045
C240	W203	2.6L Petrol	Auto	11-00	08-05	MER14331	293						
C250D	W202	2.5L Diesel	Auto	09-94	11-96	MER11191	293			CNX580		RDx217	
C250TD	W202	2.5L Turbo Diesel	Auto	11-96	01-01	MER11191	293			CNX580		RDx217	
C250TD	W202	2.5L Turbo Diesel	Man	11-96	09-98	MER11191	293			CNX580		RDx217	
C280	W202	2.8L Petrol	Auto	02-94	12-00	MER1231	293	MER12021	293	CNX622		RDx217	RDx045
C280	W202	2.8L Petrol	Auto	08-97	11-00	MER11191	293			CNX622		RDx217	RDx045
C32	W203	3.2L Petrol	Auto	11-01	09-04	MER14331	293			CNX796			
C320	W203	3.2L Petrol	Auto	11-00	08-05	MER14331	293			CNX796			
C36	W202	3.6L Petrol	Auto	09-95	04-98	MER1231	293			CNX580		RDx217	
C43	W202	4.3L Petrol	Auto	04-98	01-01	MER12571	295					RDx215	
C43T	S202	4.3L Petrol	Auto	09-98	01-01	MER12571	295					RDx215	

MODEL	SERIES	ENGINE	TRANS	YEAR FROM	YEAR TO	RADIATOR OPTION 1	PAGE	RADIATOR OPTION 2	PAGE	CONDENSER OPTION 1	CONDENSER OPTION 2	RECEIVER DRIER OPTION 1	RECEIVER DRIER OPTION 2
MERCEDES-BENZ (continued)													
CL500	C215	5.0L Petrol	Auto	03-00	02-04	MER12571	295						
CL55	C215	5.4L Petrol	Auto	07-01	11-03	MER12571	295	MER16331	295				
CL600	C215	5.5L Turbo Petrol	Auto	01-02	01-07	MER12571	295	MER16331	295				
CL600	C215	5.8L Petrol	Auto	03-00	11-03	MER16331	295						
CL65	C215	6.0L Turbo Petrol	Auto	07-04	01-07	MER16331	295						
CLK320	C208	3.2L Petrol	Auto	10-97	07-02	MER12021	293					RDX215	
CLK320	C209	3.2L Petrol	Auto	06-02	09-05	MER14331	293						
CLK430	A208	4.3L Petrol	Auto	11-00	01-04	MER12571	295						
CLK430	C208	4.3L Petrol	Auto	11-99	01-03	MER12571	295					RDX215	
CLK500	C209	5.0L Petrol	Auto	06-02	11-04	MER11181	288						
CLS350	C219	3.5L Petrol	Auto	05-05		MER12591	290						
CLS500	C219	5.0L Petrol	Auto	05-05	12-06	MER69781	295						
E200	W210	2.0L Petrol	Auto	08-00	09-05	MER10231	294	MER12741	294	CNX595		RDX930	
E200	W211	1.8L Petrol	Auto	10-04		MER69781	295						
E230	S210	2.3L Petrol	Auto	10-96	01-98	MER11191	293			CNX416		RDX930	
E230	W210	2.3L Petrol	Auto	01-96	01-98	MER10231	294					RDX930	
E240	S210	2.4L Petrol	Auto	01-98	03-03	MER10231	294			CNX416		RDX930	
E240	W210	2.4L Petrol	Auto	01-98	08-02	MER10231	294					RDX930	
E240	W211	2.6L Petrol	Auto	08-02	09-05	MER18011	295			CNX794		RDX932	
E270 CDI	W211	2.7L Turbo Diesel	Auto	08-02	09-05	MER69781	295			CNX794		RDX932	
E280	S211	3.0L Petrol	Auto	09-05		MER18011	295						
E280	S211	3.0L Turbo Diesel	Auto	09-06	12-09	MER69781	295						
E280	W124	2.8L Petrol	Auto	09-93	01-97	MER12421	289					RDX203	
E280	W210	2.8L Petrol	Auto	09-98	03-02	MER10231	294	MER20381	294	CNX595		RDX930	

MODEL	SERIES	ENGINE	TRANS	YEAR FROM	YEAR TO	RADIATOR OPTION 1	PAGE	RADIATOR OPTION 2	PAGE	CONDENSER OPTION 1	CONDENSER OPTION 2	RECEIVER DRIER OPTION 1	RECEIVER DRIER OPTION 2
E280	W211	3.0L Petrol	Auto	09-05	12-09	MER18011	295						
E280	W211	3.0L Turbo Diesel	Auto	09-05	12-09	MER18011	295						
E300	W124	3.0L Diesel	Auto	09-93	09-94	MER12421	289	MER12461	289			RDX203	
E300TD	W210	3.0L Turbo Diesel	Auto	07-97	11-99	MER11151	294					RDX930	
E320	S210	3.2L Petrol	Auto	06-97	03-03	MER10231	294			CNX416			
E320	S211	3.2L Petrol	Auto	10-03	09-05	MER69781	295						
E320	W124	3.2L Petrol	Auto	09-93	01-97	MER12421	289					RDX203	
E320	W210	3.2L Petrol	Auto	01-96	08-02	MER20381	294			CNX595		RDX930	
E320	W210	3.2L Petrol	Auto	01-96	08-02	MER10231	294	MER20381	294	CNX595		RDX930	
E320	W211	3.2L Petrol	Auto	08-02	02-06	MER69781	295			CNX794		RDX932	
E350	W211	3.5L Petrol	Auto	02-05		MER18011	295						
E430	W210	4.3L Petrol	Auto	01-98	08-02	MER11151	294	MER12741	294			RDX930	
E500	S211	5.5L Petrol	Auto	09-06	12-09	MER69781	295						
E500	W211	5.0L Petrol	Auto	03-04	09-06	MER69781	295			CNX794		RDX932	
E500	W211	5.5L Petrol	Auto	09-06	12-09	MER69781	295						
E55	S211	5.4L Petrol	Auto	03-04	09-06	MER12401	294						
E55	W210	5.4L Petrol	Auto	04-98	08-02	MER12401	294			CNX416			
E55	W211	5.4L Petrol	Auto	10-02	09-06	MER12401	294						
E63	S211	6.2L Petrol	Auto	09-06		MER69781	295						
E63	W211	6.2L Petrol	Auto	09-06		MER69781	295						
ML270CDI	W163	2.7L Turbo Diesel	Auto	02-00	12-05	MER18571	291						
ML320	W163	3.2L Petrol	Auto	09-98	03-04	MER18571	291						
ML350	W163	3.7L Petrol	Auto	04-03	09-05	MER18571	291						
ML430	W163	4.3L Petrol	Auto	03-99	11-01	MER18571	291			CNX623			
ML500	W163	5.0L Petrol	Auto	01-01	09-05	MER18571	291						
ML55	W163	5.4L Petrol	Auto	01-01	09-05	MER18571	291						

MODEL	SERIES	ENGINE	TRANS	YEAR FROM	YEAR TO	RADIATOR OPTION 1	PAGE	RADIATOR OPTION 2	PAGE	CONDENSER OPTION 1	CONDENSER OPTION 2	RECEIVER DRIER OPTION 1	RECEIVER DRIER OPTION 2
MERCEDES-BENZ (continued)													
S280	W140	2.8L Petrol	Auto	09-95	04-99	MER12201	290	MER12591	290				
S320	W140	3.2L Petrol	Auto	09-93	04-99	MER11521	291	MER12201	290			RDx213	
S320	W220	3.2L Petrol	Auto	04-99	02-04	MER16331	295	MER12591	290				
S350	W220	3.7L Petrol	Auto	02-03	02-07	MER12591	290					RDx671	
S420	W140	4.2L Petrol	Auto	09-93	04-99	MER11171	291					RDx213	
S420L	W140	4.2L Petrol	Auto	09-93	12-98	MER11171	291					RDx213	
S430	W220	4.3L Petrol	Auto	02-04	02-07	MER12571	295	MER12591	290			RDx671	
S430L	W220	4.3L Petrol	Auto	02-03	05-05	MER12571	295	MER12591	290				
S500L	W140	5.0L Petrol	Auto	09-93	09-99	MER11171	291						
S500L	W220	5.0L Petrol	Auto	02-04	01-07	MER12571	295			CNX810		RDx671	
S55	W220	5.4L Petrol	Auto	02-03	01-07	MER12571	295	MER16331	295			RDx671	
S600L	W220	5.5L Turbo Petrol	Auto	02-03	01-07	MER16331	295						
S600L	W220	5.8L Petrol	Auto	01-00	02-04	MER16331	295					RDx671	
S65L	W220	6.0L Turbo Petrol	Auto	05-05	02-07	MER16331	295					RDx671	
SL280	R129	2.8L Petrol	Auto	11-95	12-98	MER11091	288						
SPRINTER	208CDI	2.1L Turbo Diesel	Auto	03-02	12-06	MER22001	296	MER21201	297				
SPRINTER	208CDI	2.1L Turbo Diesel	Man	04-02	12-06	MER21631	297	MER21201	297				
SPRINTER	308CDI	2.1L Turbo Diesel	Auto	01-00	10-06	MER22001	296					RDx671	
SPRINTER	308CDI	2.1L Turbo Diesel	Man	05-00	10-06	MER21631	297					RDx671	
SPRINTER	308D	2.3L Diesel	Man	01-98	04-01	MER21201	297					RDx671	
SPRINTER	311CDI	2.2L Turbo Diesel	Man	04-05	01-07	MER22001	296			CNX814			
SPRINTER	312-412D	2.9L Turbo Diesel	Man	01-98	04-01	MER21431	297	MER21201	297				
SPRINTER	313-413CDI	2.1L Turbo Diesel	Auto	01-00	10-06	MER22001	296						
SPRINTER	313-413CDI	2.1L Turbo Diesel	Man	05-00		MER21631	297						
SPRINTER	313CDI	2.1L Turbo Diesel	Man	07-03	10-06	MER21631	297						
SPRINTER	413CDI	2.1L Turbo Diesel	Auto	01-00	10-06	MER22001	296					RDx671	

MODEL	SERIES	ENGINE	TRANS	YEAR FROM	YEAR TO	RADIATOR OPTION 1	PAGE	RADIATOR OPTION 2	PAGE	CONDENSER OPTION 1	CONDENSER OPTION 2	RECEIVER DRIER OPTION 1	RECEIVER DRIER OPTION 2
SPRINTER	413CDI	2.1L Turbo Diesel	Man	01-00	10-06	MER21631	297					RDX671	
V (TRUCK)	1422-48	11.0L Diesel	Man	01-92	12-92	MER21151	288						
V (TRUCK)	1734-34	11.0L Turbo Diesel	Man	01-95	12-95	MER21151	288						
V (TRUCK)	1734-36	11.0L Turbo Diesel	Man	01-96	01-98	MER14321	296						
V (TRUCK)	2222-48	10.9L Diesel	Man	01-92	12-92	MER21151	288						
V (TRUCK)	2434-32	10.9L Turbo Diesel	Man	01-94	12-94	MER21151	288						
V (TRUCK)	2434-36	10.9L Turbo Diesel	Man	01-94	01-98	MER21151	288						
V (TRUCK)	2435-32	14.6L Turbo Diesel	Man	01-96	01-98	MER14321	296						
V (TRUCK)	2534-32	10.9L Turbo Diesel	Man	01-94	01-98	MER21151	288						
V (TRUCK)	2534-52	10.9L Turbo Diesel	Man	01-94	01-98	MER21151	288						
VIANO	639	2.1L Turbo Diesel	Auto	01-10		MER19741	296	MER56131	295				RDX207
VIANO	639 SERIES	2.1L Turbo Diesel	Auto	07-05		MER19741	296						RDX207
VITO	113	2.0L Petrol	Auto	01-99	04-05	MER21411	296						
VITO	113	2.0L Petrol	Man	01-98	04-05	MER21411	296						
VITO	108CDI	2.2L Diesel	Man	07-99	04-05	MER21411	296						
VITO	108D	2.3L Diesel	Man	01-98	07-99	MER21411	296	MER21391	296				
VITO	109CDI	2.1L Turbo Diesel	Man	01-07	01-09	MER19741	296	MER56131	295				RDX207
VITO	111CDI	2.1L Turbo Diesel	Auto	01-08		MER19741	296	MER56131	295	CNX799			
VITO	111CDI	2.1L Turbo Diesel	Man	01-08		MER19741	296	MER56131	295	CNX799			
VITO	112CDI	2.1L Turbo Diesel	Auto	01-01	12-04	MER14311	296	MER21411	296	CNX798			
VITO	112CDI	2.2L Diesel	Auto	02-01	04-04	MER14311	296	MER21411	296				
VITO	115CDI	2.1L Turbo Diesel	Auto	05-05		MER21411	296	MER19741	296	CNX813			RDX207
VITO	115CDI	2.1L Turbo Diesel	Man	04-04	01-06	MER14321	296	MER56131	295				
VITO	119P	3.2L Petrol	Auto	04-04	10-06	MER21411	296	MER14321	296				RDX207
VITO	119P	3.2L Petrol	Auto	05-05	10-06	MER19741	296						
VITO	120CDI	3.0L Turbo Diesel	Auto	01-07		MER19741	296	MER56131	295				RDX207

MODEL	SERIES	ENGINE	TRANS	YEAR FROM	YEAR TO	RADIATOR OPTION 1	PAGE	RADIATOR OPTION 2	PAGE	CONDENSER OPTION 1	CONDENSER OPTION 2	RECEIVER DRIER OPTION 1	RECEIVER DRIER OPTION 2
MERCEDES-BENZ (continued)													
VITO VAN	109CDI	2.1L Turbo Diesel	Auto	04-04	01-09	MER14311	296	MER14321	296				
VITO VAN	109CDI	2.1L Turbo Diesel	Man	04-04		MER14311	296	MER14321	296				
VITO VAN	115CDI	2.1L Turbo Diesel	Auto	04-04	01-09	MER14311	296	MER14321	296				
VITO VAN	115CDI	2.1L Turbo Diesel	Man	04-04	01-07	MER14311	296	MER14321	296				
MINI													
CABRIO	R57	1.6L Petrol	Auto	03-09		MIN54591	298						
CABRIO	R57	1.6L Turbo Petrol	Auto	03-09		MIN54591	298						
CABRIO	R57	1.6L Petrol	Man	03-09		MIN54591	298						
CABRIO	R57	1.6L Turbo Petrol	Man	03-09		MIN54591	298						
CABRIO S	R52	1.6L Petrol	Man	12-04	12-08	MIN49521	298						
COOPER	R50	1.6L Petrol	Auto	03-05	03-09	MIN49501	297	MIN49521	298	CNX900		RDX6711	
COOPER	R50	1.6L Petrol	Auto	12-04	03-09	MIN49501	297	MIN49521	298	CNX900		RDX6711	
COOPER	R50	1.6L Petrol	Man	03-02	05-08	MIN49521	298	MIN54221	298	CNX900		RDX6711	
COOPER	R55	1.6L Turbo Petrol	Man	06-08		MIN54591	298						
COOPER	R56	1.6L Petrol	Auto	03-07		MIN54591	298			CNX907			
COOPER	R56	1.6L Turbo Petrol	Auto	03-07		MIN54591	298			CNX907			
COOPER	R56	1.6L Petrol	Auto	03-08		MIN54591	298			CNX907			
COOPER	R56	1.6L Turbo Diesel	Auto	05-09		MIN49511	297			CNX907			
COOPER	R56	1.6L Petrol	Man	03-07		MIN54591	298			CNX907			
COOPER	R56	1.6L Turbo Diesel	Man	05-09		MIN49511	297			CNX907			
COOPER	R56	1.6L Petrol	Man	10-10		MIN54591	298	MIN54221	298	CNX907			
COOPER	R56	1.6L Turbo Diesel	Man	10-10		MIN54221	298			CNX907			
COOPER S	R53	1.6L Petrol	Man	01-02	12-04	MIN49511	297	MIN49521	298				

MODEL	SERIES	ENGINE	TRANS	YEAR FROM	YEAR TO	RADIATOR OPTION 1	PAGE	RADIATOR OPTION 2	PAGE	CONDENSER OPTION 1	CONDENSER OPTION 2	RECEIVER DRIER OPTION 1	RECEIVER DRIER OPTION 2
MITSUBISHI													
380	DB	3.8L Petrol	Auto	09-05	09-08	MIT42038	298			CNX0190		RDX0070	
380	DB	3.8L Petrol	Man	09-05	09-08	MIT42039	298			CNX0190		RDX0070	
CHALLENGER	PA	3.0L Petrol	Auto	03-98	07-04	J42CA	299	MIT45020	299	CNX088		RDX608	
CHALLENGER	PA	3.0L Petrol	Man	03-98	07-04	J42CA	299	MIT45021	299	CNX088		RDX608	
CHARIOT (NZ)		2.4L Petrol	Auto	01-97	12-02	MIT41013	299						
COLT	RE	1.6L Petrol	Auto	09-88	05-91	MIT1208	304					RDX001	
COLT	RG	1.5L Petrol	Auto	08-04	02-08	MIT1496	299						
COLT	RG	1.5L Petrol	Man	07-06		MIT1496	299						
COLT	RG	1.5L Turbo Petrol	Man	07-06		MIT1496	299						
DIAMANTE (NZ)		2.5L Petrol	Auto	01-94	12-02	MIT42030	300						
DIAMANTE (NZ)		2.5L Petrol	Auto	01-94	12-02	MIT42030	300						
DIAMANTE (NZ)		3.0L Petrol	Auto	01-95	12-01	MIT42030	300						
DIAMANTE (NZ)		3.0L Petrol	Auto	01-95	12-01	MIT42030	300						
GALANT (NZ)	HU	2.0L Petrol	Auto	04-93	11-96	MIT41013	299						
GALANT (NZ)	HU	2.0L Petrol	Auto	04-93	12-95	MIT41013	299						
GRANDIS	BA	2.4L Petrol	Auto	05-04		MIT1144	301			CNX8490		RDX0070	
L300 EXPRESS	SA	1.6L Petrol	Man	04-80	10-82	MIT44500	302					RDX022	
L300 EXPRESS	SB	1.6L Petrol	Man	10-82	10-83	MIT44500	302					RDX022	
L300 EXPRESS	SB	1.8L Petrol	Man	10-82	10-83	MIT44500	302					RDX022	
L300 EXPRESS	SC	1.6L Petrol	Man	04-83	08-84	MIT44500	302					RDX022	
L300 EXPRESS	SC	1.8L Petrol	Man	10-83	08-84	MIT44500	302					RDX022	
L300 EXPRESS	SD	1.6L Petrol	Man	08-84	07-85	MIT44500	302					RDX022	
L300 EXPRESS	SD	1.8L Petrol	Man	08-84	07-85	MIT44500	302					RDX022	
L300 EXPRESS	SD	2.0L Petrol	Man	08-84	07-85	MIT44500	302	MIT44501	302			RDX022	

MODEL	SERIES	ENGINE	TRANS	YEAR FROM	YEAR TO	RADIATOR OPTION 1	PAGE	RADIATOR OPTION 2	PAGE	CONDENSER OPTION 1	CONDENSER OPTION 2	RECEIVER DRIER OPTION 1	RECEIVER DRIER OPTION 2
L300 EXPRESS	SE	1.6L Petrol	Man	07-85	10-86	MIT44500	302						RDx022
L300 EXPRESS	SE	2.0L Petrol	Man	07-85	10-86	MIT44501	302	MIT44525	302				RDx022
L300 EXPRESS	SF	2.0L Petrol	Man	10-86	09-90	MIT44501	302	MIT44525	302	CNX309			RDx030
L300 EXPRESS	SF	2.4L Petrol	Man	10-86	09-90	MIT44501	302	MIT44525	302	CNX309			RDx030
L300 EXPRESS	SF	2.5L Diesel	Auto	10-86	09-90	MIT44520	302						RDx030
L300 EXPRESS	SF	2.5L Diesel	Man	10-86	09-90	MIT44520	302			CNX309			RDx030
L300 EXPRESS	SG	2.0L Petrol	Auto	09-90	01-94	MIT44540	301			CNX309			RDx030
L300 EXPRESS	SG	2.0L Petrol	Man	09-90	01-94	MIT44501	302	MIT44525	302	CNX309			RDx030
L300 EXPRESS	SG	2.4L Petrol	Man	09-90	01-94	MIT44501	302	MIT44525	302	CNX309			RDx030
L300 EXPRESS	SG	2.5L Diesel	Auto	09-90	01-94	MIT44520	302			CNX309			RDx030
L300 EXPRESS	SG	2.5L Diesel	Man	09-90	01-94	MIT44520	302			CNX309			RDx030
L300 EXPRESS	SH	2.0L Petrol		01-94	09-95	MIT44540	301						
L300 EXPRESS	SH	2.0L Petrol	Auto	09-90	09-95	MIT44540	301			CNX309			RDx030
L300 EXPRESS	SH	2.0L Petrol	Man	09-90	09-95	MIT44501	302	MIT44525	302	CNX309			RDx030
L300 EXPRESS	SH	2.4L Petrol	Auto	09-90	09-95	MIT44540	301			CNX309			RDx608
L300 EXPRESS	SH	2.4L Petrol	Man	09-90	09-95	MIT44501	302	MIT44525	302	CNX309			RDx608
L300 EXPRESS	SH	2.5L Diesel	Auto	01-92	09-95	MIT44545	301			CNX309			RDx608
L300 EXPRESS	SH	2.5L Diesel	Man	01-92	09-95	MIT44520	302			CNX309			RDx608
L300 EXPRESS	SJ	2.0L Petrol	Auto	10-94	11-03	MIT44540	301			CNX408			RDx220
L300 EXPRESS	SJ	2.0L Petrol	Man	01-94	11-03	MIT44501	302	MIT44542	301	CNX408			RDx220
L300 EXPRESS	SJ	2.4L Petrol	Auto	12-94	11-03	MIT44540	301			CNX408			RDx220
L300 EXPRESS	SJ	2.4L Petrol	Man	12-94	11-03	MIT44501	302	MIT44542	301	CNX408			RDx220
L300 EXPRESS	SJ	2.5L Diesel	Man	12-94	05-04	MIT44545	301			CNX408			RDx220

MITSUBISHI (continued)

MODEL	SERIES	ENGINE	TRANS	YEAR FROM	YEAR TO	RADIATOR OPTION 1	PAGE	RADIATOR OPTION 2	PAGE	CONDENSER OPTION 1	CONDENSER OPTION 2	RECEIVER DRIER OPTION 1	RECEIVER DRIER OPTION 2
L300 EXPRESS	WA	2.4L Petrol	Auto	12-94	03-06	MIT44540	301						
L300 EXPRESS	WA	2.4L Petrol	Man	12-94	03-06	MIT44501	302	MIT44542	301				
LANCER		1.5L Petrol	Auto	01-95	12-00	MIT41030	303						
LANCER	CA	1.5L Petrol	Auto	04-89	08-90	MIT1208	304	MIT211	304			RDX603	
LANCER	CB	1.5L Petrol	Auto	09-90	09-92	MIT41013	299	MIT1208	304			RDX603	
LANCER	CB	1.5L Petrol	Man	11-90	07-96	MIT41014	304					RDX603	
LANCER	CC	1.5L Petrol	Auto	09-92	07-96	J16CA	304	MIT41013	299	CNX081	CNX085	RDX022	
LANCER	CC	1.5L Petrol	Man	09-92	07-96	J22CM	304	MIT41014	304	CNX081		RDX022	RDX408
LANCER	CC	1.6L Petrol	Auto	09-92	07-96	J16CA	304	MIT41013	299			RDX022	
LANCER	CC	1.6L Petrol	Man	09-92	07-96	J22CM	304	MIT41014	304			RDX022	
LANCER	CC	1.8L Petrol	Auto	09-92	07-96	J16CA	304	MIT41013	299	CNX081		RDX022	
LANCER	CC	1.8L Petrol	Man	09-92	07-96	J22CM	304	MIT41014	304	CNX081		RDX022	
LANCER	CC	1.8L Turbo Petrol	Man	10-92	07-96	J22CM	304	MIT41014	304	CNX081		RDX022	
LANCER	CE	1.5L Petrol	Auto	07-96	11-04	J27CA	303	MIT41030	303	CNX081	CNX083	RDX608	
LANCER	CE	1.5L Petrol	Man	07-96	11-04	MIT41040	303			CNX081	CNX083	RDX608	
LANCER	CE	1.8L Petrol	Auto	07-96	11-04	J27CA	303	MIT41030	303	CNX081		RDX608	
LANCER	CE	1.8L Petrol	Man	07-96	02-04	MIT41040	303			CNX081		RDX608	
LANCER	CE	2.0L Turbo Petrol	Man	05-01	11-01	MIT41040	303	MIT1029	303	CNX097		RDX608	RDX624
LANCER	CG	2.0L Petrol	Auto	07-02	10-03	MIT41050	303			CNX097		RDX624	
LANCER	CG	2.0L Petrol	Man	07-02	10-03	MIT41060	303			CNX097		RDX624	
LANCER	CH	2.0L Petrol	Auto	10-03	05-07	MIT41050	303				CNX098	RDX624	
LANCER	CH	2.0L Petrol	Man	10-03	05-07	MIT41060	303			CNX098		RDX624	
LANCER	CH	2.4L Petrol	Auto	08-05	10-09	MIT41050	303	MIT2233	302	CNX098		RDX624	
LANCER	CH	2.4L Petrol	Man	08-05	10-09	MIT41050	303	MIT41060	303	CNX098		RDX624	
LANCER	CY	2.0L Turbo Petrol	Man	08-05	07-08	J22CM	304						

MODEL	SERIES	ENGINE	TRANS	YEAR FROM	YEAR TO	RADIATOR OPTION 1	PAGE	RADIATOR OPTION 2	PAGE	CONDENSER OPTION 1	CONDENSER OPTION 2	RECEIVER DRIER OPTION 1	RECEIVER DRIER OPTION 2
MITSUBISHI (continued)													
LANCER	CZ	2.0L Turbo Petrol	Man	07-04	08-05	MIT1029	303			CNX097			RDX624
LIBERO (NZ)		1.8L Petrol	Auto	01-92	12-00	MIT41013	299						
MAGNA	TE	2.4L Petrol	Auto	04-96	06-97	J15CA	300	MIT42030	300	CNX080			RDX603
MAGNA	TE	2.4L Petrol	Man	04-96	06-97	J15CA	300	MIT42030	300	CNX080			RDX603
MAGNA	TE	3.0L Petrol	Auto	04-96	06-97	J15CA	300	MIT42030	300	CNX080			RDX608
MAGNA	TE	3.0L Petrol	Man	04-96	06-97	J15CA	300	MIT42030	300	CNX080			RDX608
MAGNA	TF	2.4L Petrol	Auto	06-97	03-99	J15CA	300	MIT42030	300	CNX080			RDX608
MAGNA	TF	2.4L Petrol	Man	06-97	03-99	J15CA	300	MIT42030	300	CNX080			RDX608
MAGNA	TF	3.0L Petrol	Auto	06-97	03-99	J15CA	300	MIT42030	300	CNX080			RDX608
MAGNA	TF	3.0L Petrol	Man	06-97	03-99	J15CA	300	MIT42030	300	CNX080			RDX608
MAGNA	TH	3.0L Petrol	Auto	03-99	08-00	J15CA	300	MIT42030	300	CNX080			RDX608
MAGNA	TH	3.0L Petrol	Man	03-99	08-00	J15CA	300	MIT42030	300	CNX080			RDX608
MAGNA	TH	3.5L Petrol	Auto	03-99	08-00	J15CA	300	MIT42030	300	CNX080			RDX608
MAGNA	TH	3.5L Petrol	Man	03-99	08-00	J15CA	300	MIT42030	300	CNX080			RDX608
MAGNA	TJ	3.0L Petrol	Auto	08-00	07-02	J15CA	300	MIT42030	300	CNX093			RDX608
MAGNA	TJ	3.0L Petrol	Man	08-00	07-02	J15CA	300	MIT42030	300	CNX093			RDX608
MAGNA	TJ	3.5L LPG	Auto	04-03	07-03	J15CA	300	MIT42030	300	CNX093			RDX608
MAGNA	TJ	3.5L Petrol	Auto	12-02	08-03	J15CA	300	MIT42030	300	CNX093			RDX608
MAGNA	TJ	3.5L Petrol	Man	08-00	08-03	J15CA	300	MIT42030	300	CNX093			RDX608
MAGNA	TL	3.5L LPG	Auto	07-03	10-04	J15CA	300	MIT42030	300	CNX096			RDX620
MAGNA	TL	3.5L Petrol	Auto	07-03	10-04	J15CA	300	MIT42030	300	CNX096			RDX620
MAGNA	TL	3.5L Petrol	Man	07-03	10-04	J15CA	300	MIT42030	300	CNX096			RDX620
MAGNA	TM	2.6L Petrol	Auto	04-85	02-88	MIT42010	305			CNX078			RDX026
MAGNA	TM	2.6L Petrol	Man	04-85	02-88	MIT42010	305			CNX078			RDX026

MODEL	SERIES	ENGINE	TRANS	YEAR FROM	YEAR TO	RADIATOR OPTION 1	PAGE	RADIATOR OPTION 2	PAGE	CONDENSER OPTION 1	CONDENSER OPTION 2	RECEIVER DRIER OPTION 1	RECEIVER DRIER OPTION 2
MAGNA	TN	2.6L Petrol	Auto	04-87	05-90	MIT42010	305					RDX026	
MAGNA	TN	2.6L Petrol	Man	04-87	05-90	MIT42010	305					RDX026	
MAGNA	TP	2.6L Petrol	Auto	06-89	12-91	MIT42010	305					RDX026	
MAGNA	TP	2.6L Petrol	Man	06-89	12-91	MIT42010	305					RDX026	
MAGNA	TR	2.6L Petrol	Auto	04-91	03-95	MIT42020	300			CNX076		RDX282	
MAGNA	TR	2.6L Petrol	Man	04-91	03-95	MIT42020	300			CNX076		RDX282	
MAGNA	TR	3.0L Petrol	Auto	03-93	03-95	MIT42020	300			CNX076		RDX282	
MAGNA	TS	2.6L Petrol	Auto	03-94	03-98	MIT42020	300			CNX100		RDX281	
MAGNA	TS	2.6L Petrol	Man	03-94	03-98	MIT42020	300			CNX100		RDX281	
MAGNA	TS	3.0L Petrol	Auto	03-94	03-98	MIT42020	300			CNX100		RDX281	
MAGNA	TS	3.0L Petrol	Man	03-94	03-98	MIT42020	300			CNX100		RDX281	
MAGNA	TW	3.5L LPG	Auto	10-04	05-06	J15CA	300	MIT42030	300	CNX096		RDX620	
MAGNA	TW	3.5L Petrol	Auto	10-04	05-06	J15CA	300	MIT42030	300	CNX096		RDX620	
MAGNA	TW	3.5L Petrol	Man	10-04	05-06	J15CA	300	MIT42030	300	CNX096		RDX620	
MIRAGE	CE	1.5L Petrol	Auto	07-96	08-04	J27CA	303	MIT41030	303	CNX083		RDX608	
MIRAGE	CE	1.5L Petrol	Man	07-96	08-04	MIT41040	303			CNX083		RDX608	
NIMBUS	UG	2.4L Petrol	Auto	11-98	05-05	J51CA	306			CNX8330		RDX0040	
NIMBUS	UG	2.4L Petrol	Man	11-98	05-05	J51CM	306			CNX8330		RDX0040	
OUTLANDER	ZE	2.4L Petrol	Auto	01-03	07-04	MIT1857	306	MIT1095	307	CNX084		RDX624	
OUTLANDER	ZF	2.4L Petrol	Auto	07-04	11-06	MIT1857	306	MIT1095	307	CNX084		RDX624	
OUTLANDER	ZG	2.4L Petrol	Auto	11-06		MIT1857	306						
OUTLANDER	ZG	2.4L Petrol	Man	11-07		MIT1095	307					RDX5310	
OUTLANDER	ZG	3.0L Petrol	Auto	11-06	08-08	MIT1095	307					RDX5310	
PAJERO	NF	3.0L Petrol	Auto	08-88	10-89	MIT1124	308					RDX022	
PAJERO	NF	3.0L Petrol	Man	08-88	10-89	MIT1124	308					RDX022	
PAJERO	NG	3.0L Petrol	Auto	10-89	07-91	MIT1124	308					RDX032	

MODEL	SERIES	ENGINE	TRANS	YEAR FROM	YEAR TO	RADIATOR OPTION 1	PAGE	RADIATOR OPTION 2	PAGE	CONDENSER OPTION 1	CONDENSER OPTION 2	RECEIVER DRIER OPTION 1	RECEIVER DRIER OPTION 2
PAJERO	NG	3.0L Petrol	Man	10-89	07-91	MIT1124	308						RDX032
PAJERO	NH	3.0L Petrol	Auto	05-91	12-93	MIT1124	308						RDX025
PAJERO	NH	3.0L Petrol	Man	05-91	12-93	J33CM	307	MIT1124	308				RDX025
PAJERO	NJ	2.8L Diesel	Man	12-93	11-96	J32CM	307			CNX2100			RDX281
PAJERO	NJ	2.8L Turbo Diesel	Man	12-93	11-96	J32CM	307			CNX2100			RDX281
PAJERO	NJ	3.0L Petrol	Man	12-93	11-96	J32CM	307	J33CM	307				RDX281
PAJERO	NJ	3.5L Petrol	Man	02-95	11-96	J33CM	307						RDX281
PAJERO	NK	2.8L Turbo Diesel	Man	11-96	09-97	J32CM	307			CNX2100			RDX281
PAJERO	NK	2.8L Diesel	Man	11-96	10-97	J32CM	307			CNX2100			RDX281
PAJERO	NK	3.0L Petrol	Man	11-96	09-97	J32CM	307	J33CM	307	CNX2110			RDX281
PAJERO	NK	3.5L Petrol	Man	11-96	09-97	J33CM	307			CNX2120			RDX281
PAJERO	NL	2.8L Turbo Diesel	Man	09-97	05-00	J32CM	307			CNX2100			RDX281
PAJERO	NL	3.5L Petrol	Man	09-97	09-99	J33CM	307			CNX2120			RDX281
PAJERO	NM	2.8L Turbo Diesel	Man	05-00	11-02	MIT45090	307						RDX0040
PAJERO	NM	3.2L Turbo Diesel	Auto	05-02	11-02	MIT45095	307			CNX918	CNX841		RDX0050
PAJERO	NM	3.2L Turbo Diesel	Man	05-02	11-02	MIT45095	307			CNX918	CNX841		RDX0050
PAJERO	NM	3.5L Petrol	Auto	05-00	11-02	MIT45090	307						RDX0040
PAJERO	NM	3.5L Petrol	Man	05-00	11-02	MIT45090	307						RDX0040
PAJERO	NP	3.2L Turbo Diesel	Auto	11-02	10-06	MIT45095	307			CNX918	CNX841		RDX0050
PAJERO	NP	3.2L Turbo Diesel	Man	11-02	10-06	MIT45095	307			CNX918	CNX841		RDX0050
PAJERO	NP	3.5L Petrol	Auto	11-02	09-03	MIT45090	307	MIT45095	307				RDX0050
PAJERO	NP	3.5L Petrol	Man	11-02	07-04	MIT45090	307						
PAJERO	NP	3.8L Petrol	Auto	09-03	12-06	MIT45090	307	MIT45095	307				RDX0040
PAJERO	NP	3.8L Petrol	Man	07-04	10-06	MIT45090	307						

mitsubishi (continued)

MODEL	SERIES	ENGINE	TRANS	YEAR FROM	YEAR TO	RADIATOR OPTION 1	PAGE	RADIATOR OPTION 2	PAGE	CONDENSER OPTION 1	CONDENSER OPTION 2	RECEIVER DRIER OPTION 1	RECEIVER DRIER OPTION 2
PAJERO	NS	3.2L Turbo Diesel	Auto	10-06	12-08	MIT45095	307			CNX918	CNX841	RDX0050	
PAJERO	NS	3.8L Petrol	Auto	10-06	12-08	MIT45090	307			CNX918			
PAJERO	NS	3.8L Petrol	Man	10-06	12-08	MIT45090	307			CNX918			
PAJERO	NT	3.2L Turbo Diesel	Auto	12-08		MIT45095	307			CNX918	CNX841	RDX0050	
PAJERO	NT	3.2L Turbo Diesel	Man	12-08		MIT45095	307			CNX918	CNX841	RDX0050	
PAJERO	NT	3.8L Petrol	Auto	12-08		MIT45090	307						
PAJERO	NT	3.8L Petrol	Man	12-08	12-09	MIT45090	307						
PAJERO IO	QA	1.6L Petrol	Man	03-99	10-01	J48CM	307			CNX094			
PAJERO IO	QA	1.8L Petrol	Man	03-99	10-01	J48CM	307			CNX094			
PAJERO IO	QA	2.0L Petrol	Man	10-01	04-03	J48CM	307			CNX094			
RVR (NZ)		2.0L Petrol	Auto	01-91	12-98	MIT41013	299						
RVR (NZ)		2.0L Petrol	Man	01-91	12-98	MIT41013	299						
STARWAGON	SB	1.8L Petrol	Man	10-82	05-83	MIT44500	302						
STARWAGON	SC	1.8L Petrol	Man	05-83	09-84	MIT44500	302						
STARWAGON	SD	1.8L Petrol	Man	10-85	12-85	MIT44500	302						
STARWAGON	SE	1.8L Petrol	Man	01-86	10-86	MIT44500	302						
STARWAGON	SF	2.0L Petrol	Auto	10-86	10-90	MIT44540	301					RDX608	
STARWAGON	SF	2.0L Petrol	Man	10-86	10-90	MIT44501	302	MIT44525	302			RDX608	
STARWAGON	SF	2.4L Petrol	Auto	10-86	10-90	MIT44540	301					RDX608	
STARWAGON	SF	2.4L Petrol	Man	10-86	10-90	MIT44501	302	MIT44525	302			RDX608	
STARWAGON	SG	2.0L Petrol	Auto	10-90	08-91	MIT44540	301					RDX608	
STARWAGON	SG	2.0L Petrol	Man	10-90	08-91	MIT44501	302	MIT44525	302			RDX608	
STARWAGON	SG	2.4L Petrol	Auto	10-90	08-91	MIT44540	301					RDX608	
STARWAGON	SG	2.4L Petrol	Man	10-90	08-91	MIT44501	302	MIT44525	302			RDX608	
STARWAGON	SH	2.0L Petrol	Auto	09-91	09-94	MIT44540	301					RDX608	
STARWAGON	SH	2.0L Petrol	Man	09-91	09-94	MIT44501	302	MIT44527	302			RDX608	

Vehicle Application Guide

MODEL	SERIES	ENGINE	TRANS	YEAR FROM	YEAR TO	RADIATOR OPTION 1	PAGE	RADIATOR OPTION 2	PAGE	CONDENSER OPTION 1	CONDENSER OPTION 2	RECEIVER DRIER OPTION 1	RECEIVER DRIER OPTION 2
MITSUBISHI (continued)													
STARWAGON	SH	2.4L Petrol	Auto	09-91	09-94	MIT44540	301						RDx608
STARWAGON	SH	2.4L Petrol	Man	09-91	09-94	MIT44501	302	MIT44525	302				RDx608
STARWAGON	SJ	2.0L Petrol	Auto	09-95	07-01	MIT44540	301						RDx608
STARWAGON	SJ	2.0L Petrol	Man	01-97	01-02	MIT44542	301						
STARWAGON	SJ	2.0L Petrol	Man	09-95	07-01	MIT44501	302	MIT44542	301				RDx608
STARWAGON	WA	2.0L Petrol	Auto	09-94	05-04	MIT44540	301						RDx220
STARWAGON	WA	2.0L Petrol	Man	09-94	05-04	MIT44501	302	MIT44542	301				RDx220
STARWAGON	WA	2.4L Petrol	Auto	09-94	05-04	MIT44540	301						RDx220
STARWAGON	WA	2.4L Petrol	Man	09-94	01-01	MIT44501	302	MIT44525	302				RDx220
STARWAGON	WA	3.0L Petrol	Auto	09-94	11-96	MIT44540	301						RDx220
TRITON	ME	2.5L Diesel	Man	10-86	12-88	J40CM	311	MIT43012	311	CNX402			RDx030
TRITON	ME	2.6L Petrol	Man	10-86	12-88	MIT43010	311			CNX402			RDx030
TRITON	MF	2.5L Diesel	Man	07-88	09-89	J40CM	311	MIT43012	311	CNX402			RDx030
TRITON	MF	2.6L Petrol	Man	07-88	09-89	MIT43010	311			CNX402			RDx030
TRITON	MG	2.5L Diesel	Man	09-89	09-90	J40CM	311	MIT43012	311				RDx030
TRITON	MG	2.6L Petrol	Man	09-89	09-90	MIT43010	311						RDx030
TRITON	MH	2.5L Turbo Diesel	Man	09-90	07-92	J40CM	311	MIT43012	311	CNX402			RDx030
TRITON	MH	2.5L Diesel	Man	09-90	08-91	J40CM	311	MIT43012	311	CNX402			RDx030
TRITON	MH	2.6L Petrol	Man	09-90	07-92	MIT43010	311			CNX402			RDx030
TRITON	MH	3.0L Petrol	Man	09-90	12-92	J40CM	311	MIT43016	311	CNX402			RDx030
TRITON	MJ	2.5L Turbo Diesel	Man	08-91	10-96	J40CM	311	MIT43012	311	CNX402			RDx001
TRITON	MJ	2.5L Diesel	Man	08-91	12-96	J40CM	311	MIT43012	311	CNX402			RDx001
TRITON	MJ	2.6L Petrol	Man	08-91	10-96	MIT43010	311			CNX402			RDx001
TRITON	MJ	3.0L Petrol	Man	08-91	10-96	MIT43016	311			CNX402			RDx022
TRITON	MK	2.4L Petrol	Auto	10-96	08-00	MIT1692	310	MIT45021	299	CNX087	CNX095		RDx608

MODEL	SERIES	ENGINE	TRANS	YEAR FROM	YEAR TO	RADIATOR OPTION 1	PAGE	RADIATOR OPTION 2	PAGE	CONDENSER OPTION 1	CONDENSER OPTION 2	RECEIVER DRIER OPTION 1	RECEIVER DRIER OPTION 2
TRITON	MK	2.4L Petrol	Man	10-96	04-07	MIT1692	310	MIT2702	310	CNX087	CNX095	RDX608	
TRITON	MK	2.8L Diesel	Man	01-96	04-04	MIT43022	310	MIT1692	310	CNX087	CNX095	RDX608	
TRITON	MK	2.8L Turbo Diesel	Man	04-03	04-07	MIT43022	310	MIT45021	299	CNX087	CNX095	RDX608	
TRITON	MK	3.0L Petrol	Auto	10-96	04-07	MIT45021	299			CNX087	CNX095	RDX608	
TRITON	ML	2.4L Petrol	Man	04-07		J58CA	310	J58CM	309				
TRITON	ML	3.2L Turbo Diesel	Auto	07-08		J57CA	309			CNX819		RDX610	
TRITON	ML	3.2L Turbo Diesel	Man	01-06	09-09	J57CM	309			CNX819		RDX610	
TRITON	ML	3.5L Petrol	Auto	01-06		J58CA	310	J59CA	309	CNX820		RDX610	
TRITON	ML	3.5L Petrol	Man	01-06	07-09	J58CM	309	J59CA	309	CNX820		RDX610	
VERADA	KE	3.5L Petrol	Auto	10-96	06-97	J15CA	300	MIT42030	300	CNX080		RDX608	
VERADA	KF	3.5L Petrol	Auto	06-97	03-00	J15CA	300	MIT42030	300	CNX080		RDX608	
VERADA	KH	3.5L Petrol	Auto	03-99	08-00	J15CA	300	MIT42030	300	CNX080		RDX608	
VERADA	KJ	3.5L Petrol	Auto	08-00	07-02	J15CA	300	MIT42030	300	CNX093		RDX608	
VERADA	KL	3.5L Petrol	Auto	07-03	10-04	J15CA	300	MIT42030	300	CNX096		RDX620	
VERADA	KR	3.0L Petrol	Auto	08-91	03-95	MIT42020	300			CNX076		RDX282	
VERADA	KS	3.0L Petrol	Auto	03-94	10-97	MIT42020	300			CNX100		RDX608	
VERADA	KS	3.0L Petrol	Man	11-95	05-96	MIT42020	300			CNX100		RDX608	
VERADA	KW	3.5L Petrol	Auto	10-04	05-06	J15CA	300	MIT42030	300	CNX096		RDX620	
MORRIS													
MINI		.8L Petrol	Man	06-66	05-69	MORRIS-1	312	MORRIS-2	312				
MINI		1.0L Petrol	Man	01-62	06-71	MORRIS-1	312	MORRIS-2	312				
MINI		1.1L Petrol	Man	05-69	12-73	MORRIS-1	312	MORRIS-2	312				
MINI		1.3L Petrol	Man	06-65	01-69	MORRIS-1	312	MORRIS-2	312				
MINOR	1000	1.0L Petrol	Man	04-57	04-64	MORRIS-1	312	MORRIS-2	312				

Vehicle Application Guide

Vehicle Application Guide

MODEL	SERIES	ENGINE	TRANS	YEAR FROM	YEAR TO	RADIATOR OPTION 1	PAGE	RADIATOR OPTION 2	PAGE	CONDENSER OPTION 1	CONDENSER OPTION 2	RECEIVER DRIER OPTION 1	RECEIVER DRIER OPTION 2
NISSAN													
720	P720	1.8L Petrol	Man	01-80	01-86	NIS41020	313						
720	PG720	1.8L Petrol	Man	01-80	01-86	NIS41020	313						
720	PGY720	1.8L Petrol	Man	05-80	01-86	NIS41020	313						
720	UP720	1.8L Petrol	Man	01-80	12-85	NIS41020	313						
720	USY720	1.8L Petrol	Man	01-80	01-85	NIS41020	313						
120Y	VB210	1.2L Petrol	Auto	06-77	01-79	NIS46000	187	NIS46002	187				
120Y	VB210	1.2L Petrol	Man	06-77	01-79	NIS46000	187	NIS46002	187				
200SX	S14	2.0L Turbo Petrol	Auto	10-94	11-00	NIS1213	312			CNX564		RDY610	
200SX	S14	2.0L Turbo Petrol	Man	10-94	11-00	NIS1213	312			CNX564		RDY610	
200SX	S15	2.0L Turbo Petrol	Auto	11-00	02-03	NIS1213	312					RDY610	
200SX	S15	2.0L Turbo Petrol	Man	11-00	02-03	NIS1213	312					RDY610	
300ZX	Z31	3.0L Turbo Petrol	Auto	01-87	11-89	NIS42005	313						
300ZX	Z31	3.0L Petrol	Auto	05-84	12-85	NIS42005	313						
300ZX	Z31	3.0L Turbo Petrol	Man	01-87	11-89	NIS42005	313						
300ZX	Z31	3.0L Petrol	Man	05-84	12-85	NIS42005	313						
300ZX	Z32	3.0L Turbo Petrol	Auto	01-89		NIS1182	313						
300ZX	Z32	3.0L Petrol	Auto	12-89	10-96	NIS42005	313	NIS1182	313			RDY224	
300ZX	Z32	3.0L Petrol	Man	12-89	10-96	NIS42005	313					RDY224	
300ZX	Z32	3.0L Turbo Petrol	Man	12-89	10-96	NIS42005	313						
350Z	Z33A	3.5L Petrol	Auto	02-03	03-08	NIS42007	313			CNX827		RDY627	
350Z	Z33A	3.5L Petrol	Man	07-03	11-05	NIS42008	313			CNX827		RDY627	
BLUEBIRD		1.8L Petrol	Auto	01-95	12-98	NIS40085	313						
BLUEBIRD		1.8L Petrol	Auto	01-87	12-91	NIS40035	188						
BLUEBIRD		1.8L Petrol	Auto	01-89	12-91	NIS40035	188						

MODEL	SERIES	ENGINE	TRANS	YEAR FROM	YEAR TO	RADIATOR OPTION 1	PAGE	RADIATOR OPTION 2	PAGE	CONDENSER OPTION 1	CONDENSER OPTION 2	RECEIVER DRIER OPTION 1	RECEIVER DRIER OPTION 2
BLUEBIRD		1.8L Petrol	Man	01-90	12-97	NIS40085	313						
BLUEBIRD		2.0L Petrol	Auto	01-90	12-98	NIS40085	313						
BLUEBIRD		2.0L Petrol	Auto	01-88	12-91	NIS40035	188						
BLUEBIRD		2.0L Petrol	Man	01-90	12-98	NIS40085	313						
BLUEBIRD	U13	2.4L Petrol	Auto	09-93	12-97	NIS40085	313	F17CA	314			RDX605	
BLUEBIRD	U13	2.4L Petrol	Man	09-93	12-97	NIS40085	313	F17CA	314			RDX605	
CEFIRO (NZ)		2.0L Petrol	Auto	01-94	12-98	NIS42015	314						
CEFIRO (NZ)		2.0L Petrol	Auto	01-94	12-98	NIS42015	314						
CEFIRO (NZ)		2.5L Petrol	Auto	01-94	12-98	NIS42015	314						
CEFIRO (NZ)		2.5L Petrol	Auto	01-94	12-98	NIS42015	314						
DUALIS	J10	2.0L Petrol	Man	10-07		NIS1234	314						
LUCINO (NZ)		1.5L Petrol	Auto	01-95	12-99	NIS40045	315						
LUCINO (NZ)		1.5L Petrol	Auto	01-94	12-98	NIS40045	315						
MAXIMA	A32	3.0L Petrol	Auto	02-95	12-99	NIS42015	314	F16CA	314	CNX525		RDX610	
MAXIMA	A32	3.0L Petrol	Man	02-95	10-96	NIS42015	314	F16CA	314	CNX525		RDX610	
MAXIMA	A33	3.0L Petrol	Auto	12-99	12-03	NIS42015	314	F16CA	314	CNX450		RDX220	
MAXIMA	J30	3.0L Petrol	Auto	04-90	01-95	NIS42010	315						
MAXIMA	J30	3.0L Petrol	Auto	01-95	01-96	NIS42010	315						
MAXIMA	J30	3.0L Petrol	Auto	04-90	02-95	NIS42000	315	NIS42010	315	CNX530		RDX220	
MAXIMA	J31	3.5L Petrol	Auto	01-06	07-09	NIS1508	315			CNX451			
MICRA	K12	1.4L Petrol	Auto	10-07		NIS1233	316						
MURANO	Z50	3.5L Petrol	Auto	01-05	01-09	NIS41060	316			CNX534			
MURANO	Z51	3.5L Petrol	Auto	01-09		NIS41060	316						
NAVARA	D21	2.0L Petrol	Auto	01-86	12-92	NIS41001	318	NIS41004	318			RDX033	
NAVARA	D21	2.0L Petrol	Man	01-86	12-97	NIS41001	318	NIS41004	318			RDX033	

MODEL	SERIES	ENGINE	TRANS	YEAR FROM	YEAR TO	RADIATOR OPTION 1	PAGE	RADIATOR OPTION 2	PAGE	CONDENSER OPTION 1	CONDENSER OPTION 2	RECEIVER DRIER OPTION 1	RECEIVER DRIER OPTION 2
NISSAN (continued)													
NAVARA	D21	2.4L Petrol	Auto	01-86	05-92	NIS41001	318	NIS41004	318				RDx033
NAVARA	D21	2.4L Petrol	Man	01-86	01-92	NIS41001	318	NIS41004	318				RDx033
NAVARA	D21	2.7L Diesel	Man	01-88	03-98	NIS1339	317						RDx033
NAVARA	D21	3.0L Petrol	Auto	01-92	03-98	NIS41001	318	NIS41004	318				RDx033
NAVARA	D21	3.0L Petrol	Man	01-92	03-98	NIS41040	317						RDx033
NAVARA	D22	2.4L Petrol	Auto	08-99	12-05	NIS41038	317			CNX539			RDx610
NAVARA	D22	2.4L Petrol	Man	03-97	07-99	NIS41040	317			CNX539			RDx610
NAVARA	D22	2.5L Turbo Diesel	Man	01-08		NIS1783	317						
NAVARA	D22	2.7L Diesel	Man	03-97	12-01	NIS41040	317	NIS1783	317	CNX539			RDx610
NAVARA	D22	3.0L Petrol	Auto	06-00	12-05	NIS41038	317			CNX539			RDx610
NAVARA	D22	3.0L Turbo Diesel	Man	12-01	01-08	NIS41040	317	NIS1783	317	CNX539			RDx610
NAVARA	D22	3.0L Petrol	Man	06-00	12-05	NIS41040	317			CNX539	CNX559		RDx610
NAVARA	D22	3.2L Diesel	Man	03-97	12-01	NIS1783	317			CNX539			RDx610
NAVARA	D22	3.3L Petrol	Man	02-03	07-06	NIS41015	317			CNX539			RDx610
NAVARA	D40	2.5L Turbo Diesel	Auto	07-08		NIS1505	316			CNX824			
NAVARA	D40	4.0L Petrol	Auto	05-10		NIS1507	316			CNX824			
NAVARA	D40	4.0L Petrol	Man	05-10		NIS1506	316			CNX824			
NX		2.0L Petrol	Auto	10-91	09-95	F17CA	314						
NX		2.0L Petrol	Man	10-91	09-95	F17CA	314						
NXR		2.0L Petrol	Auto	10-91	09-95	F17CA	314						
NXR		2.0L Petrol	Man	10-91	09-95	F17CA	314						
PATHFINDER	D21	2.4L Petrol	Man	12-86	10-92	NIS41001	318						RDx033

MODEL	SERIES	ENGINE	TRANS	YEAR FROM	YEAR TO	RADIATOR OPTION 1	PAGE	RADIATOR OPTION 2	PAGE	CONDENSER OPTION 1	CONDENSER OPTION 2	RECEIVER DRIER OPTION 1	RECEIVER DRIER OPTION 2
PATHFINDER	D21	3.0L Petrol	Auto	09-92	11-95	NIS41001	318	NIS41004	318			RDX033	
PATHFINDER	D21	3.0L Petrol	Man	09-92	11-95	NIS41004	318					RDX033	
PATHFINDER	R50	3.3L Petrol	Auto	02-99	07-05	NIS41015	317			CNX546	CNX559	RDX232	
PATHFINDER	R51	2.5L Turbo Diesel	Auto	05-10		NIS1505	316			CNX824			
PATHFINDER	R51	2.5L Turbo Diesel	Man	05-10		NIS1504	316			CNX824			
PATHFINDER	R51	4.0L Petrol	Auto	07-05		NIS1507	316			CNX824			
PATHFINDER	R51 ST-L	2.5L Turbo Diesel	Auto	07-05		NIS1505	316			CNX824			
PATHFINDER	R51 ST-L	2.5L Turbo Diesel	Man	07-05		NIS1504	316			CNX824			
PATROL	GQ	2.8L Turbo Diesel	Man	01-94	12-97	NIS41007	203	NIS4025	322	CNX535		RDX221	
PATROL	GQ	4.2L Diesel	Auto	02-88	01-95	NIS4026	322			CNX023	CNX022	RDX033	RDX221
PATROL	GQ	4.2L Petrol	Auto	02-88	12-97	NIS4030	322			CNX023	CNX022	RDX033	RDX221
PATROL	GQ	4.2L Petrol	Man	01-88	12-97	NIS41005	203	NIS4029	322	CNX023	CNX022	RDX033	RDX221
PATROL	GQ	4.2L Diesel	Man	01-88	12-99	NIS41007	203	NIS4025	322	CNX023	CNX022	RDX033	RDX221
PATROL	GU	2.8L Turbo Diesel	Man	12-97	04-01	NIS2260	319	NIS4046	321	CNX579	CNX533	RDX232	RDX626
PATROL	GU	3.0L Turbo Diesel	Auto	01-10		NIS2260	319	NIS4045	320	CNX533	CNX579	RDX232	RDX626
PATROL	GU	3.0L Turbo Diesel	Auto	04-00	10-01	NIS4045	320			CNX533	CNX579	RDX221	
PATROL	GU	3.0L Turbo Diesel	Man	08-07		NIS4046	321			CNX579	CNX533	RDX221	
PATROL	GU	4.2L Diesel	Man	04-98	02-03	NIS2259	319	NIS4042	321	CNX579	CNX533	RDX221	RDX232
PATROL	GU	4.2L Turbo Diesel	Man	10-01	10-04	NIS2259	319	NIS4042	321	CNX533	CNX579	RDX232	RDX221
PATROL	GU	4.5L Petrol	Auto	12-97	04-01	NIS2262	321	NIS4040	321	CNX533	CNX579	RDX232	
PATROL	GU	4.5L Petrol	Man	12-97	04-01	NIS2261	321	NIS4039	321	CNX533	CNX579	RDX232	
PATROL	GU	4.8L Petrol	Auto	10-01	10-04	NIS2790	320	NIS2044	319	CNX533	CNX579	RDX232	
PATROL	GU	4.8L Petrol	Man	10-01	10-04	NIS2735	320			CNX533	CNX579	RDX221	RDX232
PATROL	MK (160)	4.0L Petrol	Man	06-80	02-88	NIS41200	323						
PATROL	MQ	2.8L Petrol	Man	11-85	02-88	NIS41200	323						

Vehicle Application Guide

Vehicle Application Guide

MODEL	SERIES	ENGINE	TRANS	YEAR FROM	YEAR TO	RADIATOR OPTION 1	PAGE	RADIATOR OPTION 2	PAGE	CONDENSER OPTION 1	CONDENSER OPTION 2	RECEIVER DRIER OPTION 1	RECEIVER DRIER OPTION 2
NISSAN (continued)													
PATROL	MQ	3.3L Turbo Diesel	Man	01-84	12-87	NIS41000	323						
PATROL	MQ	3.3L Diesel	Man	06-80	12-87	NIS41000	323						
PATROL	MQ (160)	2.8L Petrol	Man	01-82	01-88	NIS41200	323						
PATROL	MQ (160)	4.0L Petrol	Man	06-80	01-88	NIS41200	323						
PATROL	MQ-MK	2.8L Petrol	Man	06-80	02-88	NIS41200	323						
PINTARA	R31	2.0L Petrol	Auto	01-86	10-93	NIS40030	323	NIS40035	188	CNX528		RD X033	
PINTARA	R31	2.0L Petrol	Man	01-86	12-90	NIS40030	323			CNX528		RD X033	
PINTARA	U12	2.0L Petrol	Auto	12-90	04-93	NIS40035	188					RD X033	
PINTARA	U12	2.0L Petrol	Man	12-90	04-93	NIS40035	188					RD X033	
PINTARA	U12	2.4L Petrol	Auto	12-90	04-93	NIS40035	188					RD X033	
PINTARA	U12	2.4L Petrol	Man	12-90	04-93	NIS40030	323	NIS40035	188			RD X033	
PULSAR	N12	1.5L Petrol	Man	01-95	12-00	NIS40045	315						
PULSAR	N12	1.3L Petrol	Man	01-82	07-87	NIS46020	323					RD X025	
PULSAR	N12	1.5L Petrol	Man	05-83	07-87	NIS46020	323					RD X026	
PULSAR	N12	1.6L Petrol	Man	01-86	05-88	NIS46020	323					RD X027	
PULSAR	N13	1.6L Petrol	Auto	07-87	09-91	NIS40025	213	NIS46150	214			RD X033	
PULSAR	N13	1.8L Petrol	Auto	07-87	09-91	NIS40025	213	NIS46150	214			RD X033	
PULSAR	N13	1.8L Petrol	Man	07-87	09-91	NIS40025	213	NIS46150	214			RD X033	
PULSAR	N14	1.6L Petrol	Auto	10-91	10-95	NIS40045	315	NIS40050	324	CNX523		RD X223	
PULSAR	N14	1.6L Petrol	Man	10-91	10-95	NIS40045	315	HOL1106	324	CNX523	CNX536	RD X223	
PULSAR	N14	2.0L Petrol	Man	10-91	10-95	HOL1106	324			CNX523	CNX536	RD X223	
PULSAR	N15	1.6L Petrol	Auto	10-95	07-00	NIS40045	315	NIS40050	324	CNX521		RD X232	
PULSAR	N15	1.6L Petrol	Man	10-95	07-00	NIS40045	315	HOL1106	324	CNX521	CNX523	RD X232	
PULSAR	N15	2.0L Petrol	Man	10-95	01-01	HOL1106	324			CNX521	CNX523	RD X232	
PULSAR	N16	1.6L Petrol	Auto	07-00	02-04	NIS40050	324	NIS1130	325	CNX540		RD X238	

MODEL	SERIES	ENGINE	TRANS	YEAR FROM	YEAR TO	RADIATOR OPTION 1	PAGE	RADIATOR OPTION 2	PAGE	CONDENSER OPTION 1	CONDENSER OPTION 2	RECEIVER DRIER OPTION 1	RECEIVER DRIER OPTION 2
PULSAR	N16	1.6L Petrol	Man	07-00	02-04	NIS40052	324		324	CNX540		RDY238	
PULSAR	N16	1.8L Petrol	Auto	07-00	02-06	NIS40050	324	NIS1130	325	CNX540		RDY235	
PULSAR	N16	1.8L Petrol	Man	07-00	02-06	NIS40052	324	NIS1130	325	CNX540		RDY235	
PULSAR VECTOR	N13	1.8L Petrol	Auto	07-87	09-91	NIS40025	213	NIS46150	214			RDY033	
PULSAR VECTOR	N13	1.8L Petrol	Man	07-87	09-91	NIS40025	213	NIS46150	214			RDY033	
SAFARI		4.2L Diesel	Auto	01-87	12-97	NIS4026	322			CNX533	CNX579	RDY232	RDY626
SAFARI		4.2L Diesel	Auto	01-87	12-97	NIS4026	322			CNX533	CNX579	RDY232	RDY626
SENTRA (NZ)		1.4L Petrol	Auto	01-91	12-96	NIS40045	315						
SENTRA (NZ)		1.5L Petrol	Auto	01-96	12-99	NIS40045	315						
SENTRA (NZ)		1.6L Petrol	Auto	01-91	12-96	NIS40045	315						
SENTRA (NZ)		1.6L Petrol	Auto	01-91	12-98	NIS40045	315						
SILVIA		2.0L Petrol	Auto	01-93	12-98	NIS1213	312						
SKYLINE		2.0L Petrol	Auto	01-93	12-98	NIS1772	325						
SKYLINE		2.5L Petrol	Auto	01-93	12-98	NIS1772	325						
SKYLINE	HR31	2.0L Petrol	Auto	01-87	12-89	NIS40030	323						
SKYLINE	HR31	2.0L Turbo Petrol	Auto	01-87	12-89	NIS40030	323						
SKYLINE	HR31	2.0L Petrol	Man	01-87	12-89	NIS40030	323						
SKYLINE	HR31	2.0L Turbo Petrol	Man	01-87	12-89	NIS40030	323			CNX528		RDY033	
SKYLINE	HR32	2.6L Petrol	Man	01-89	03-94	NIS40030	323						
SKYLINE	HR33	2.0L Petrol	Man	01-92	12-97	NIS1773	325						
SKYLINE	HR33	2.5L Petrol	Auto	01-93	12-98	NIS1772	325						
SKYLINE	HR33	2.5L Turbo Petrol	Auto	02-93	12-98	NIS1772	325						
SKYLINE	HR33	2.5L Petrol	Man	01-93	12-98	NIS1773	325						
SKYLINE	HR33	2.5L Turbo Petrol	Man	02-93	12-98	NIS1773	325						
SKYLINE	HR33	2.6L Petrol	Auto	01-93	12-98	NIS1772	325						

Vehicle Application Guide

Vehicle Application Guide

MODEL	SERIES	ENGINE	TRANS	YEAR FROM	YEAR TO	RADIATOR OPTION 1	PAGE	RADIATOR OPTION 2	PAGE	CONDENSER OPTION 1	CONDENSER OPTION 2	RECEIVER DRIER OPTION 1	RECEIVER DRIER OPTION 2
NISSAN (continued)													
SKYLINE	HR33	2.6L Petrol	Man	01-93	12-98	NIS1773	325						
SKYLINE	R31	3.0L Petrol	Auto	07-86	12-90	NIS40030	323			CNX528		RDY033	
SKYLINE	R31	3.0L Petrol	Man	07-86	12-90	NIS40030	323			CNX528		RDY033	
SUNNY (NZ)		1.5L Petrol	Auto	01-94	12-98	NIS40085	313						
SUNNY (NZ)		1.5L Petrol	Man	01-94	12-98	NIS40045	315						
TERRANO		2.7L Diesel	Auto	01-95	12-98	NIS41015	317						
TERRANO	R20	2.7L Turbo Diesel	Auto	01-88	12-96	NIS41015	317					RDY226	
TERRANO	R20	2.7L Turbo Diesel	Man	01-88	12-96	NIS41015	317			CNX549		RDY226	RDX605
TIIDA	C11	1.8L Petrol	Auto	02-06		NIS1956	326						
TIIDA	C11	1.8L Petrol	Man	02-06		NIS40058	326						
X-TRAIL	T30	2.5L Petrol	Auto	01-01	12-03	NIS41030	327			CNX531		RDY627	
X-TRAIL	T30	2.5L Petrol	Man	01-01	12-03	NIS41035	327	NIS1229	326	CNX531		RDY627	
X-TRAIL	T31	2.5L Petrol	Auto	10-07		NIS1229	326			CNX457		RDY627	
X-TRAIL	T31	2.5L Petrol	Man	10-07		NIS1229	326			CNX457		RDY627	
PEUGEOT													
206		1.6L Petrol	Auto	06-01	02-08	PEU17531	327			CNX567		RDY239	
206		1.6L Petrol	Man	02-01	02-08	PEU17531	327			CNX567		RDY239	
206		2.0L Petrol	Man	10-99	07-07	PEU17531	327			CNX567		RDY239	
206	XR	1.4L Petrol	Man	05-06	02-08	PEU17531	327			CNX567			
206	XR 1.4	1.4L Petrol	Auto	03-02	02-08	PEU17531	327			CNX567			
206	XR 1.4	1.4L Petrol	Man	03-02	02-08	PEU17531	327			CNX567			
306	N3	1.8L Petrol	Man	04-94	07-97	PEU17291	327	PEU10261	178			RDY242	
306	N3	2.0L Petrol	Man	07-94	09-96	PEU10261	178					RDY242	

MODEL	SERIES	ENGINE	TRANS	YEAR FROM	YEAR TO	RADIATOR OPTION 1	PAGE	RADIATOR OPTION 2	PAGE	CONDENSER OPTION 1	CONDENSER OPTION 2	RECEIVER DRIER OPTION 1	RECEIVER DRIER OPTION 2
306	N5	1.8L Petrol	Man	01-97	09-00	PEU17291	327	PEU10261	178			RDX242	
306	N5	1.9L Turbo Diesel	Man	08-99	12-00	PEU17291	327					RDX242	RDX245
306	N5	2.0L Petrol	Man	07-97	11-03	PEU10261	178					RDX242	
307		1.6L Petrol	Auto	12-01	02-09	PEU67101	327					RDX6333	
307		2.0L Turbo Diesel	Auto	01-01	12-07	PEU67101	327			CNX556		RDX6333	
307		2.0L Petrol	Auto	12-01	10-05	PEU67101	327					RDX6333	RDX347
307		2.0L Turbo Diesel	Man	05-05	10-05	PEU67101	327					RDX347	
307	CC	2.0L Petrol	Auto	10-05	07-09	PEU67101	327					RDX347	
405	D60	1.9L Petrol	Auto	12-91	05-94	PEU19611	328					RDX240	
405	D70	1.9L Turbo Diesel	Man	09-95	03-98	PEU16551	328	PEU19601	328			RDX240	
405	D70	2.0L Petrol	Auto	05-93	09-96	PEU19611	328					RDX240	
405	D70	2.0L Petrol	Man	02-89	12-95	PEU16551	328	PEU19601	328			RDX240	
406	D8	2.9L Petrol	Man	09-97	08-99	PEU07251	328			CNX558			
406	D9	2.9L Petrol	Man	08-99	09-04	PEU07251	328			CNX558			
206 CC		1.6L Petrol	Auto	11-01	07-07	PEU17531	327			CNX567		RDX239	
206 CC		1.6L Petrol	Man	03-02	07-07	PEU17531	327			CNX567		RDX239	
206 CC		2.0L Petrol	Man	11-01	07-07	PEU17531	327			CNX567		RDX239	
307 TOURING		2.0L Petrol	Auto	10-03	10-05	PEU67101	327					RDX6333	
PARTNER		1.6L Petrol	Man	09-08		CIT19511	178						
PARTNER	HDI	1.6L Turbo Diesel	Man	09-08		CIT19511	178						
PORSCHE													
911	996	3.6L Petrol	Auto	01-01	01-05	POR13791	329	POR13791	329				
911	996	3.6L Petrol	Man	08-03	01-04	POR14291	329	POR65141	329				
911	996	3.6L Turbo Petrol	Man	11-00	01-06	POR65131	328	POR65141	329				
911	997	3.6L Turbo Petrol	Auto	08-06	12-08	POR33671	330	POR30581	330				

MODEL	SERIES	ENGINE	TRANS	YEAR FROM	YEAR TO	RADIATOR OPTION 1	PAGE	RADIATOR OPTION 2	PAGE	CONDENSER OPTION 1	CONDENSER OPTION 2	RECEIVER DRIER OPTION 1	RECEIVER DRIER OPTION 2
PORSCHE (continued)													
911	997	3.6L Petrol	Man	12-08		POR33671	330	POR30581	330				
911	997	3.8L Petrol	Man	12-08		POR33671	330	POR30581	330				
911	996 CARRERA	3.4L Petrol	Man	01-98	08-01	POR14291	329	POR65141	329			RDX576	
911	996 CARRERA	3.6L Petrol	Man	08-01	11-05	POR65141	329	POR65111	329				
911	996 CARRERA	3.6L Petrol	Man	08-03	09-05	POR65141	329	POR65111	329				
911	996 GT2	3.6L Turbo Petrol	Man	08-01	08-02	POR65131	328	POR65141	329				
911	996 GT3	3.6L Petrol	Man	01-99	01-06	POR14291	329	POR13791	329				
911	996 TARGA	3.6L Petrol	Man	12-01	09-05	POR65131	328	POR65141	329				
911	997 CARRERA	3.6L Petrol	Man	10-04	12-08	POR14291	329	POR13791	329				
911	997 CARRERA	3.6L Petrol	Man	12-08		POR33671	330	POR30581	330				
911	997 CARRERA	3.8L Petrol	Man	12-08		POR33671	330	POR30581	330				
CAYENNE		3.6L Petrol	Auto	12-06		AUD19001	164			CNX910		RDX922	
CAYENNE		3.6L Petrol	Man	12-06	03-08	AUD19001	164			CNX910		RDX922	
CAYENNE		4.8L Turbo Petrol	Auto	12-06		AUD19001	164			CNX910		RDX922	
CAYENNE	S	4.5L Petrol	Man	06-03	08-06	AUD19001	164			CNX910		RDX922	
CAYENNE	S	4.8L Petrol	Auto	12-06		AUD19001	164			CNX910		RDX922	
CAYENNE	S	4.8L Petrol	Man	12-06	03-08	AUD19001	164			CNX910		RDX922	
PROTON													
GEN.2	CM	1.6L Petrol	Auto	10-04		PRO1729	331	P3CA	330				
GEN.2	CM	1.6L Petrol	Man	10-04		PRO1728	330	P3CM	330				
JUMBUCK		1.5L Petrol	Man	02-03		PRO51010	331						
PERSONA		1.3L Petrol	Man	08-99	08-02	MIT41014	304						
PERSONA		1.5L Petrol	Auto	11-96	08-99	MIT41013	299			CNX660	CNX0690		RDX281

MODEL	SERIES	ENGINE	TRANS	YEAR FROM	YEAR TO	RADIATOR OPTION 1	PAGE	RADIATOR OPTION 2	PAGE	CONDENSER OPTION 1	CONDENSER OPTION 2	RECEIVER DRIER OPTION 1	RECEIVER DRIER OPTION 2
PERSONA		1.5L Petrol	Man	11-96	05-00	MIT41014	304			CNX660	CNX0690	RDx281	
PERSONA		1.6L Petrol	Auto	11-96	08-99	MIT41013	299					RDx281	
PERSONA		1.6L Petrol	Man	11-96	08-99	MIT41014	304					RDx281	
SATRIA		1.3L Petrol	Man	08-99	05-03	MIT41014	304			CNX0690		RDx281	
SATRIA	C90	1.5L Petrol	Auto	02-97	08-99	MIT41013	299			CNX660		RDx281	
SATRIA	C90	1.5L Petrol	Man	02-97	08-99	MIT41014	304			CNX0690		RDx281	
SATRIA	C90	1.6L Petrol	Auto	08-99	02-01	MIT41013	299			CNX660		RDx281	
SATRIA	C90	1.6L Petrol	Man	08-99	02-01	MIT41014	304			CNX0690		RDx281	
SATRIA	C90	1.8L Petrol	Man	01-99	12-05	MIT41014	304			CNX0690		RDx281	
SAVVY	BT	1.1L Petrol	Man	02-06		PRO1727	332						
WAJA	CF	1.6L Petrol	Auto	12-01	10-05	PRO1727	332	PRO1787	332				
WAJA	CF	1.6L Petrol	Man	12-01	10-05	PRO1786	332						
WIRA		1.5L Petrol	Auto	05-95	11-96	MIT41013	299			CNX660		RDx281	
WIRA		1.5L Petrol	Man	05-95	11-96	MIT41014	304	PRO51010	331	CNX660		RDx281	
WIRA		1.6L Petrol	Auto	05-95	11-96	MIT41013	299			CNX660		RDx281	
WIRA		1.6L Petrol	Man	05-95	11-96	MIT41014	304	PRO51010	331	CNX660		RDx281	
WIRA AEROBACK		1.5L Petrol	Auto	05-95	11-96	MIT41013	299			CNX660		RDx281	
WIRA AEROBACK		1.5L Petrol	Man	05-95	11-96	MIT41014	304	PRO51010	331	CNX660		RDx281	
WIRA AEROBACK		1.6L Petrol	Auto	05-95	11-96	MIT41013	299			CNX660		RDx281	
WIRA AEROBACK		1.6L Petrol	Man	05-95	11-96	MIT41014	304	PRO51010	331	CNX660		RDx281	
RENAULT													
CLIO		1.4L Petrol	Auto	12-01	07-08	REN19671	333			CNX901		RDx540	
CLIO		1.4L Petrol	Man	12-01	07-06	REN19671	333			CNX901		RDx540	
CLIO	B140	1.6L Petrol	Man	12-01	07-06	REN17781	333	REN19671	333	CNX901		RDx540	
CLIO	B210	2.0L Petrol	Man	09-04	11-06	REN17781	333	REN19671	333	CNX901		RDx540	

MODEL	SERIES	ENGINE	TRANS	YEAR FROM	YEAR TO	RADIATOR OPTION 1	PAGE	RADIATOR OPTION 2	PAGE	CONDENSER OPTION 1	CONDENSER OPTION 2	RECEIVER DRIER OPTION 1	RECEIVER DRIER OPTION 2
RENAULT (continued)													
KANGOO	X61	1.5L Turbo Diesel	Man	10-10		REN71791	333						
KANGOO	X76	1.6L Petrol	Man	08-04		REN71791	333						
LAGUNA	BG01B	2.9L Petrol	Auto	03-02	05-06	REN16291	333			CNX902		RDX502	
LAGUNA	G010	2.9L Petrol	Auto	03-02	05-07	REN16291	333			CNX902		RDX502	
MEGANE		1.9L Turbo Diesel	Auto	07-07		REN19661	334						
MEGANE		1.9L Turbo Diesel	Man	07-07	08-09	REN72031	333						
MEGANE		2.0L Turbo Petrol	Man	09-04	07-06	REN72031	333						
MEGANE	PHASE II	2.0L Petrol	Man	04-09		REN72031	333						
MEGANE	PHASE II	2.0L Turbo Petrol	Man	07-06		REN72031	333						
MEGANE	X84	1.6L Petrol	Auto	05-01	10-04	REN19661	334			CNX904			
MEGANE	X84	1.6L Petrol	Man	05-01	10-04	REN19661	334	REN81131	333	CNX904			
MEGANE	X84	2.0L Petrol	Auto	03-04		REN19661	334			CNX904			
MEGANE	X84	2.0L Petrol	Man	12-03	03-10	REN19661	334	REN72031	333	CNX904			
SCENIC		1.6L Petrol	Man	05-01	09-02	REN19661	334			CNX904			
SCENIC		2.0L Petrol	Auto	05-01	02-05	REN19661	334						
SCENIC		2.0L Petrol	Man	05-01	02-05	REN19661	334						
SCENIC	J84	2.0L Petrol	Auto	02-05	01-07	REN19661	334						
SCENIC	J84	2.0L Petrol	Man	02-05	01-07	REN19661	334						
SCENIC RX4	B30	2.0L Petrol	Man	05-01	08-03	REN19661	334						
SAAB													
900		2.0L Petrol	Auto	01-84	10-92	SAA20531	335					RDX341	
900		2.0L Turbo Petrol	Auto	03-97	07-98	SAA20531	335					RDX341	
900		2.0L Petrol	Man	01-82	03-98	SAA05651	335	SAA20661	335			RDX341	

MODEL	SERIES	ENGINE	TRANS	YEAR FROM	YEAR TO	RADIATOR OPTION 1	PAGE	RADIATOR OPTION 2	PAGE	CONDENSER OPTION 1	CONDENSER OPTION 2	RECEIVER DRIER OPTION 1	RECEIVER DRIER OPTION 2
900		2.0L Turbo Petrol	Man	01-86	07-98	SAA05651	335		335			RDX341	
900		2.0L Petrol	Man	01-87	01-91	SAA05651	335	SAA20661	335			RDX341	
900		2.3L Petrol	Auto	02-94	06-98	SAA20531	335					RDX344	
900		2.3L Petrol	Man	02-94	06-98	SAA20661	335					RDX344	
900		2.5L Petrol	Auto	02-94	03-98	SAA20531	335					RDX344	
900		2.5L Petrol	Man	02-94	03-98	SAA20661	335					RDX344	
900	TU4	2.0L Turbo Petrol	Man	02-80	12-85	SAA05651	335						
900	TU5	2.0L Turbo Petrol	Man	01-83	12-84	SAA05651	335						
9000		2.0L Petrol	Auto	01-87	04-91	SAA20781	334					RDX340	
9000		2.0L Turbo Petrol	Auto	06-88	03-91	SAA20781	334					RDX340	
9000		2.3L Petrol	Auto	01-90	11-94	SAA20781	334					RDX340	RDX342
9000		2.3L Turbo Petrol	Auto	03-91	12-97	SAA20781	334					RDX340	
9000		3.0L Petrol	Auto	02-95	03-98	SAA20781	334					RDX342	
9-3		2.0L Turbo Petrol	Auto	10-03		HOL71211	234			CNX877		RDX344	
9-3		2.0L Turbo Petrol	Man	01-98	02-05	HOL71211	234			CNX877		RDX344	
9-3		2.3L Petrol	Auto	06-98	11-98	SAA72401	334			CNX575		RDX344	
9-3	LINEAR, VECTOR, AERO	2.0L Turbo Petrol	Auto	10-03		HOL71211	234			CNX877		RDX344	
9-3	LINEAR, VECTOR, AERO	2.0L Turbo Petrol	Man	10-03		HOL71211	234			CNX877		RDX347	
9-5 ESTATE		2.0L Turbo Petrol	Auto	07-99	11-01	SAA72401	334			CNX578		RDX346	
9-5 ESTATE		2.0L Turbo Petrol	Man	07-99	11-01	SAA72401	334			CNX578		RDX346	
9-5 ESTATE		2.3L Turbo Petrol	Auto	05-99	11-01	SAA72401	334			CNX578		RDX346	
9-5 ESTATE		2.3L Turbo Petrol	Man	05-99	11-01	SAA72401	334			CNX578		RDX346	
9-5 SportEstate		2.3L Turbo Petrol	Auto	11-01	12-02	SAA72401	334			CNX578		RDX346	
SEAT													
9-5 SportEstate		2.3L Turbo Petrol	Man	11-01	03-04	SAA72401	334			CNX578		RDX346	

MODEL	SERIES	ENGINE	TRANS	YEAR FROM	YEAR TO	RADIATOR OPTION 1	PAGE	RADIATOR OPTION 2	PAGE	CONDENSER OPTION 1	CONDENSER OPTION 2	RECEIVER DRIER OPTION 1	RECEIVER DRIER OPTION 2
SEAT (continued)													
CORDOBA		1.8L Petrol	Man	01-95	08-98	VW14541	335					RDX908	
IBIZA		1.4L Petrol	Man	01-95	09-98	VW14541	335						
SKODA													
OCTAVIA		2.0L Petrol	Auto	10-07	03-10	VW81091	159						
OCTAVIA	AMBIENTE	1.9L Turbo Diesel	Man	10-07		VW26701	158	VW65121	158	CNX870		RDX370	
OCTAVIA	ELEGANCE	2.0L Turbo Diesel	Man	10-07	12-09	VW74041	158						
SMART													
FORFOUR	W454	1.5L Turbo Petrol	Man	03-06	02-08	MER12551	336						
FORTWO	A451	1.0L Petrol	Man	02-08		MER12551	336						
FORTWO	A451	1.0L Turbo Petrol	Man	02-08		MER12551	336						
FORTWO	C451	1.0L Petrol	Man	02-08		MER12551	336						
FORTWO	C451	1.0L Turbo Petrol	Man	02-08		MER12551	336						
ROADSTER		7L Turbo Petrol	Man	11-03	02-08	MER19751	337						
SSANGYONG													
MUSSO		2.9L Turbo Diesel	Auto	07-96	08-98	SSM0001	337					RDX476	
MUSSO	SPORTS	2.9L Turbo Diesel	Auto	02-04	09-07	SSM0001	337					RDX476	
SUBARU													
1400		1.4L Petrol	Man	01-75	12-75	TOY09380	360	E118CM	359	CNX1330			RDX0070
1600		1.6L Petrol	Auto	05-76	01-79	SUB56000	337						
1600		1.6L Petrol	Man	05-76	01-80	SUB56000	337						
BRUMBY	AU5	1.8L Petrol	Man	10-80	01-95	SUB56001	337						

MODEL	SERIES	ENGINE	TRANS	YEAR FROM	YEAR TO	RADIATOR OPTION 1	PAGE	RADIATOR OPTION 2	PAGE	CONDENSER OPTION 1	CONDENSER OPTION 2	RECEIVER DRIER OPTION 1	RECEIVER DRIER OPTION 2
BRUMBY	SUMMER SPECIAL	1.8L Petrol	Man	10-80	12-94	SUB56001	337						
DL LEONE		1.4L Petrol	Auto	01-75	05-76	SUB56000	337						
DL LEONE		1.4L Petrol	Man	01-75	05-76	SUB56000	337						
DL LEONE		1.6L Petrol	Auto	05-76	09-80	SUB56000	337						
DL LEONE		1.6L Petrol	Man	05-76	09-80	SUB56000	337						
DL LEONE		1.8L Petrol	Man	12-84	01-95	SUB56001	337						
FORESTER		2.5L Turbo Petrol	Auto	07-05		SUB56024	337						
FORESTER		2.5L Petrol	Auto	07-05	03-08	SUB56030	338	SUB56032	338				
FORESTER		2.5L Turbo Petrol	Man	07-05		SUB56024	337						
FORESTER		2.5L Petrol	Man	07-05	03-08	SUB1759	338						
FORESTER	SF5	2.0L Petrol	Auto	08-97	07-02	SUB1755	338	SUB1756	338	CNX705		RDX610	RDX609
FORESTER	SF5	2.0L Petrol	Man	08-97	07-02	SUB1759	338	SUB1864	338	CNX705		RDX610	
FORESTER	SF5K	2.0L Turbo Petrol	Auto	09-98	07-02	SUB1755	338	SUB1756	338	CNX705		RDX610	RDX609
FORESTER	SF5K	2.0L Turbo Petrol	Man	09-98	07-02	SUB1759	338	SUB1864	338	CNX705		RDX610	
FORESTER	SG9	2.5L Petrol	Auto	07-02	12-07	SUB56030	338	SUB56032	338				
FORESTER	SG9	2.5L Petrol	Man	07-02	12-09	SUB1862	338	SUB56025	337				
FORESTER	SG9K	2.5L Turbo Petrol	Auto	08-03	07-05	SUB56030	338	SUB56032	338				
FORESTER	SG9K	2.5L Turbo Petrol	Man	08-03	07-05	SUB1759	338						
GL LEONE	AC5	1.8L Petrol	Auto	04-85	01-87	SUB56001	337						
GL LEONE	AK5	1.8L Petrol	Man	12-84	06-95	SUB56001	337						
IMPREZA		1.5L Petrol	Auto	01-94	12-00	SUB56020	340			CNX700	CNX701	RDX224	RDX610
IMPREZA		1.5L Petrol	Auto	01-94	12-00	SUB56020	340			CNX700	CNX701	RDX220	RDX610
IMPREZA		1.8L Petrol	Man	05-96	11-96	SUB56021	340			CNX700	CNX701	RDX220	RDX610
IMPREZA		2.0L Petrol	Auto	09-05	08-07	SUB56024	337			CNX723			
IMPREZA		2.0L Petrol	Auto	01-93	12-98	SUB56020	340			CNX700	CNX701	RDX220	RDX610

MODEL	SERIES	ENGINE	TRANS	YEAR FROM	YEAR TO	RADIATOR OPTION 1	PAGE	RADIATOR OPTION 2	PAGE	CONDENSER OPTION 1	CONDENSER OPTION 2	RECEIVER DRIER OPTION 1	RECEIVER DRIER OPTION 2
SUBARU (continued)													
IMPREZA		2.0L Turbo Petrol	Man	01-99	12-99	SUB1754	340	SUB1759	338	CNX700		RDx610	
IMPREZA		2.0L Petrol	Man	09-05	08-07	SUB1862	338	SUB56025	337	CNX723			
IMPREZA		2.0L Petrol	Man	11-95	08-96	SUB1754	340						
IMPREZA		2.5L Turbo Petrol	Man	09-06		SUB1864	338	SUB56025	337			RDx5310	
IMPREZA	GC	1.6L Petrol	Auto	04-93	12-98	SUB56020	340			CNX700	CNX701	RDx610	RDx610
IMPREZA	GC	1.6L Petrol	Man	04-93	12-98	SUB56021	340			CNX700	CNX701	RDx220	RDx610
IMPREZA	GC	1.8L Petrol	Auto	01-95	12-95	SUB56020	340			CNX700	CNX701	RDx220	RDx610
IMPREZA	GC	1.8L Petrol	Auto	04-93	12-96	SUB56020	340			CNX700	CNX701	RDx220	RDx610
IMPREZA	GC	1.8L Petrol	Man	04-93	12-96	SUB56021	340			CNX701	CNX700	RDx220	RDx220
IMPREZA	GC	2.0L Turbo Petrol	Auto	01-98	12-00	SUB1758	341						
IMPREZA	GC	2.0L Petrol	Auto	03-97	12-00	SUB1755	338	SUB1756	339	CNX701		RDx610	
IMPREZA	GC	2.0L Turbo Petrol	Auto	11-96	12-99	SUB1755	338	SUB1756	339	CNX701		RDx610	
IMPREZA	GC	2.0L Petrol	Man	05-96	12-00	SUB1754	340	SUB1759	338	CNX701		RDx610	
IMPREZA	GC	2.0L Turbo Petrol	Man	11-96	12-00	SUB1754	340	SUB1759	338	CNX700		RDx220	
IMPREZA	GD	2.0L Petrol	Auto	01-05	08-07	SUB56024	337			CNX723		RDx5310	
IMPREZA	GD	2.0L Petrol	Auto	10-00	09-05	SUB1755	338	SUB1756	339	CNX701	CNX723	RDx610	
IMPREZA	GD	2.0L Turbo Petrol	Auto	10-01	09-05	SUB1755	338	SUB1756	339	CNX701		RDx610	
IMPREZA	GD	2.0L Petrol	Man	01-07	12-07	SUB1862	338	SUB56025	337	CNX723			
IMPREZA	GD	2.0L Petrol	Man	10-00	09-05	SUB1754	340	SUB1759	338	CNX701		RDx610	
IMPREZA	GD	2.0L Turbo Petrol	Man	10-01	09-05	SUB1754	340	SUB1759	338	CNX700		RDx220	
IMPREZA	GD	2.0L Turbo Petrol	Man	11-02	09-05	SUB1754	340			CNX700	CNX701	RDx220	
IMPREZA	GD	2.5L Petrol	Auto	08-04	09-05	SUB56024	337						
IMPREZA	GD	2.5L Petrol	Auto	10-01	11-02	SUB1755	338	SUB1756	339				
IMPREZA	GD	2.5L Petrol	Man	08-04	09-05	SUB1862	338	SUB56025	337				

MODEL	SERIES	ENGINE	TRANS	YEAR FROM	YEAR TO	RADIATOR OPTION 1	PAGE	RADIATOR OPTION 2	PAGE	CONDENSER OPTION 1	CONDENSER OPTION 2	RECEIVER DRIER OPTION 1	RECEIVER DRIER OPTION 2
IMPREZA	GD	2.5L Turbo Petrol	Man	09-05	02-08	SUB1864	338	SUB56025	337			RDX5310	
IMPREZA	GD	2.5L Petrol	Man	10-01	11-02	SUB1759	338	SUB56025	337				
IMPREZA	GF	1.6L Petrol	Auto	11-96	08-98	SUB1755	338	SUB56020	340	CNX701		RDX610	RDX610
IMPREZA	GF	1.6L Petrol	Man	09-95	08-98	SUB56021	340			CNX700	CNX701	RDX220	RDX610
IMPREZA	GF	1.8L Petrol	Auto	04-93	11-96	SUB56020	340			CNX701	CNX700	RDX220	RDX220
IMPREZA	GF	1.8L Petrol	Man	04-93	11-96	SUB56021	340			CNX700	CNX701	RDX220	RDX610
IMPREZA	GF	2.0L Petrol	Auto	11-96	08-98	SUB1755	338	SUB1756	339	CNX701		RDX610	
IMPREZA	GF	2.0L Petrol	Auto	11-96	12-00	SUB1856	342						
IMPREZA	GF	2.0L Turbo Petrol	Auto	11-96	12-99	SUB1755	338	SUB1756	339	CNX701		RDX610	
IMPREZA	GF	2.0L Petrol	Man	11-96	12-00	SUB1754	340	SUB1759	338	CNX701		RDX610	
IMPREZA	GF	2.0L Turbo Petrol	Man	11-96	12-99	SUB1754	340	SUB1759	338	CNX700		RDX220	
IMPREZA	GG	2.0L Petrol	Auto	06-01	08-07	SUB56024	337			CNX701		RDX610	
IMPREZA	GG	2.0L Petrol	Auto	10-00	12-05	SUB1755	338	SUB1756	339	CNX701		RDX610	
IMPREZA	GG	2.0L Turbo Petrol	Auto	10-01	09-05	SUB1755	338	SUB1756	339	CNX701		RDX610	
IMPREZA	GG	2.0L Petrol	Man	09-05	08-07	SUB1864	338	SUB56025	337	CNX701	CNX723	RDX610	
IMPREZA	GG	2.0L Petrol	Man	10-00	09-05	SUB1754	340	SUB1759	338	CNX701		RDX610	
IMPREZA	GG	2.0L Turbo Petrol	Man	10-01	09-05	SUB1754	340	SUB1759	338	CNX700		RDX220	
IMPREZA	GG	2.5L Petrol	Auto	08-04	09-05	SUB56024	337						
IMPREZA	GG	2.5L Turbo Petrol	Man	09-05	09-07	SUB1862	338	SUB56025	337			RDX5310	
IMPREZA	GH	2.5L Turbo Petrol	Man	01-07		SUB1864	338			CNX705		RDX609	
IMPREZA	GM	2.0L Turbo Petrol	Man	08-99	12-99	SUB1754	340						
IMPREZA	GR	2.5L Turbo Petrol	Man	01-07		SUB1864	338			CNX705		RDX609	
LEGACY		2.0L Petrol	Auto	01-93	12-98	SUB56040	341						
LEGACY		2.0L Petrol	Auto	01-93	12-98	SUB56040	341						
LEGACY		2.0L Petrol	Auto	01-98	12-03	SUB1758	341						

MODEL	SERIES	ENGINE	TRANS	YEAR FROM	YEAR TO	RADIATOR OPTION 1	PAGE	RADIATOR OPTION 2	PAGE	CONDENSER OPTION 1	CONDENSER OPTION 2	RECEIVER DRIER OPTION 1	RECEIVER DRIER OPTION 2
SUBARU (continued)													
LEGACY		2.2L Petrol	Auto	01-93	12-98	SUB56040	341						
LEGACY		2.5L Petrol	Auto	01-94	12-99	SUB1631	341						
LEGACY		2.5L Petrol	Auto	01-94	12-99	SUB1631	341						
LEGACY		2.5L Petrol	Man	01-94	12-99	SUB56060	341						
LEONE		1.8L Petrol	Auto	01-84	07-88	SUB56001	337						
LEONE		1.8L Turbo Petrol	Auto	01-87	07-88	SUB56001	337						
LEONE		1.8L Turbo Petrol	Man	01-86	12-86	SUB56001	337						
LEONE		1.8L Petrol	Man	01-88	09-90	SUB56001	337					RDx224	
LEONE	AC4	1.8L Petrol	Auto	12-84	07-88	SUB56001	337						
LEONE	AC4	1.8L Petrol	Man	01-82	08-88	SUB56001	337						
LEONE	AC7	1.8L Petrol	Auto	01-88	09-90	SUB56001	337					RDx224	
LEONE	AN5	1.8L Petrol	Auto	01-88	09-90	SUB56001	337					RDx224	
LEONE	AN5	1.8L Petrol	Man	01-88	09-90	SUB56001	337					RDx224	
LEONE	AW4	1.8L Petrol	Man	01-84	12-84	SUB56001	337					RDx320	
LIBERTY		2.0L Turbo Petrol	Auto	07-02	09-03	SUB56024	337						
LIBERTY		2.0L Petrol	Auto	10-98	09-03	SUB1757	343	SUB1856	342	CNX707		RDx610	
LIBERTY		2.0L Petrol	Man	03-99	09-03	SUB1758	341	SUB1864	338	CNX707		RDx610	
LIBERTY		2.0L Turbo Petrol	Man	08-01	09-03	SUB1758	341	SUB1864	338	CNX702	CNX8660	RDx220	RDx610
LIBERTY		2.0L Turbo Petrol	Man	09-92	06-95	SUB1070	343			CNX702		RDx220	
LIBERTY		2.2L Petrol	Auto	10-89	02-00	SUB56040	341	SUB56055	344	CNX702		RDx220	
LIBERTY		2.2L Petrol	Man	10-89	11-98	SUB1070	343	SUB56030	338	CNX702		RDx220	
LIBERTY		2.5L Petrol	Auto	01-03	08-03	SUB1757	343	SUB56060	341	CNX707		RDx610	
LIBERTY		2.5L Petrol	Auto	11-96	02-00	SUB1631	341	SUB56060	341			RDx610	
LIBERTY		2.5L Petrol	Man	03-99	09-03	SUB1754	340	SUB1758	341	CNX707		RDx610	
LIBERTY		3.0L Petrol	Auto	08-04	10-08	K9CA	342						
LIBERTY		3.0L Petrol	Man	08-04	10-08	K9CM	342						

MODEL	SERIES	ENGINE	TRANS	YEAR FROM	YEAR TO	RADIATOR OPTION 1	PAGE	RADIATOR OPTION 2	PAGE	CONDENSER OPTION 1	CONDENSER OPTION 2	RECEIVER DRIER OPTION 1	RECEIVER DRIER OPTION 2
LIBERTY	2.5i	2.5L Petrol	Auto	09-03	08-07	SUB1856	342		342	CNX7750		RDX0040	
LIBERTY	2.5i	2.5L Petrol	Man	09-03	08-07	SUB1856	342		342	CNX7750		RDX0040	
LIBERTY	GT	2.0L Turbo Petrol	Auto	08-04	09-06	SUB1856	342		342	CNX7750		RDX0040	
LIBERTY	GT	2.0L Turbo Petrol	Man	08-04	12-05	SUB1856	342		342	CNX7750		RDX0040	
LIBERTY	GT STI	2.0L Turbo Petrol	Man	10-05	09-06	SUB1856	342		342	CNX7750		RDX0040	
OUTBACK	3.0R	3.0L Petrol	Auto	01-00	10-08	K5CA	344	K9CA	342				
OUTBACK	BG9	2.5L Petrol	Auto	09-96	10-98	SUB56060	341			CNX821			
OUTBACK	BG9	2.5L Petrol	Man	09-97	10-98	SUB56060	341			CNX821			
OUTBACK	BH9	2.5L Petrol	Auto	10-98	09-03	SUB1757	343			CNX4971		RDX0040	
OUTBACK	BH9	2.5L Petrol	Man	10-98	09-03	SUB1758	341			CNX4971		RDX0040	
OUTBACK	BHE	3.0L Petrol	Auto	10-00	09-03	K5CA	344	K9CA	342	CNX4971		RDX0040	
OUTBACK	BP9	2.5L Petrol	Auto	09-03	08-07	SUB1757	343	SUB1856	342	CNX7750		RDX0040	
OUTBACK	BP9	2.5L Petrol	Man	09-03	08-07	SUB1757	343	SUB1856	342	CNX7750		RDX0040	
TRIBECA	3.0R	3.0L Petrol	Auto	11-06	12-07	SUB1482	345			CNX724			
TRIBECA	3.6R	3.6L Petrol	Auto	10-08		SUB1482	345			CNX724			
SUZUKI													
APV	GD	1.6L Petrol	Man	08-05		H59CM	345			CNX8160			
BALENO		1.6L Petrol	Auto	04-95	03-02	H18CA	346	H19CA	346			RDX604	
BALENO		1.6L Petrol	Man	04-95	03-02	H19CM	346	H20CM	346			RDX604	
BALENO	GA41	1.8L Petrol	Man	03-96	01-02	H19CM	346	H20CM	346			RDX604	
BALENO	GC41	1.8L Petrol	Auto	10-96	06-99	H18CA	346	H19CA	346			RDX604	
BALENO	GC41	1.8L Petrol	Man	10-96	06-99	H19CM	346	H20CM	346			RDX604	
ESCUDO (NZ)		1.6L Petrol	Auto	01-88	10-97	H24CA	347						
ESCUDO (NZ)		1.6L Petrol	Auto	01-90	12-97	SUZ58020	347						
ESCUDO (NZ)		1.6L Petrol	Auto	01-90	12-97	SUZ58020	347						
GRAND VITARA		2.7L Petrol	Auto	09-05	09-08	SUZ1223	347	H67CA	347			RDX0050	
GRAND VITARA		2.7L Petrol	Man	06-06	07-08	H67CA	347						

MODEL	SERIES	ENGINE	TRANS	YEAR FROM	YEAR TO	RADIATOR OPTION 1	PAGE	RADIATOR OPTION 2	PAGE	CONDENSER OPTION 1	CONDENSER OPTION 2	RECEIVER DRIER OPTION 1	RECEIVER DRIER OPTION 2
SUZUKI (continued)													
GRAND VITARA	JT	2.0L Petrol	Auto	06-06	07-08	SUZ1224	347		347			RDX0050	
GRAND VITARA	JT	2.0L Petrol	Man	06-06	07-08	SUZ1224	347		347			RDX0050	
GRAND VITARA	SQ625	2.5L Petrol	Auto	04-98	09-05	H23CA	348		348			RDX0050	
GRAND VITARA	SQ625	2.5L Petrol	Man	04-98	09-05	H23CM	348		348			RDX0050	
GRAND VITARA	SV-SQ420	2.0L Petrol	Auto	05-99	09-05	H23CA	348		348			RDX0050	
GRAND VITARA	SV-SQ420	2.0L Petrol	Man	05-99	09-05	H36CM	348		348			RDX0050	
GRAND VITARA	XL7	2.7L Petrol	Auto	07-01	11-04	H42CA	348	SUZ1223	347				
GRAND VITARA	XL7	2.7L Petrol	Man	07-01	01-06	H42CM	348		348			RDX0050	
IGNIS	HV51	1.3L Petrol	Auto	10-00	02-06	H39CA	226		226	CNX1950		RDX0050	
IGNIS	HV51	1.3L Petrol	Man	10-00	02-06	H39CM	226		226	CNX1950		RDX0050	
IGNIS	HV81S	1.5L Petrol	Man	08-03	02-06	H39CM	226		226	CNX1950		RDX0050	
IGNIS	HX51	1.3L Petrol	Auto	10-00	02-06	H39CA	226		226	CNX1950		RDX0050	
IGNIS	HX51	1.3L Petrol	Man	10-00	02-06	H39CM	226		226	CNX1950		RDX0050	
JIMINY	2000MY	1.3L Petrol	Auto	10-00		H35CA	349		349				
JIMINY	2000MY	1.3L Petrol	Man	10-00		H35CM	349		349				
JIMINY	B33C	1.3L Petrol	Auto	12-00	09-02	H35CA	349		349				
JIMINY	B33C	1.3L Petrol	Man	12-00	09-02	H35CM	349		349				
JIMINY	B33V	1.3L Petrol	Auto	10-98	10-00	H35CA	349		349				
JIMINY	B33V	1.3L Petrol	Man	10-98	10-00	H35CM	349		349				
JIMINY	SIERRA	1.3L Petrol	Man	02-08		H68CM	349		349				
LIANA	RA31	1.6L Petrol	Auto	09-02	02-05	H45CA	349		349				
LIANA	RA31	1.6L Petrol	Man	09-02	02-05	H45CM	349		349				
LIANA	RA51	1.8L Petrol	Auto	02-04	11-07	H45CA	349		349				
LIANA	RA51	1.8L Petrol	Man	02-04	11-07	H45CM	349		349				
LIANA	RC31	1.6L Petrol	Auto	11-01	02-05	H45CA	349		349				
LIANA	RC31	1.6L Petrol	Man	11-01	02-05	H45CM	349		349				
LIANA	RC51	1.8L Petrol	Auto	02-04	11-07	H45CA	349		349				

MODEL	SERIES	ENGINE	TRANS	YEAR FROM	YEAR TO	RADIATOR OPTION 1	PAGE	RADIATOR OPTION 2	PAGE	CONDENSER OPTION 1	CONDENSER OPTION 2	RECEIVER DRIER OPTION 1	RECEIVER DRIER OPTION 2
LIANA	RC51	1.8L Petrol	Man	02-04	11-07	H45CM	349						
SAMURAI (NZ)		1.3L Petrol	Man	01-84	12-89	SUZ58003	350						
SIERRA		1.0L Petrol	Man	02-85	12-88	SUZ58001	350					RDx086	
SIERRA	K	1.0L Petrol	Man	07-81	12-88	SUZ58001	350					RDx086	
SIERRA	SJ50	1.3L Petrol	Man	03-85	03-90	SUZ58003	350	SUZ58110	215			RDx160	
SIERRA	SJ51	1.3L Petrol	Man	02-85	12-91	SUZ58003	350					RDx160	
SIERRA	SJ70	1.3L Petrol	Man	01-89	07-99	H7CA	350	SUZ58110	215			RDx160	
SIERRA	SJ80	1.3L Petrol	Man	03-90	07-99	H7CA	350	SUZ58110	215			RDx160	
SIERRA	V	1.0L Petrol	Man	07-81	10-84	SUZ58001	350					RDx086	
SWIFT		1.5L Petrol	Auto	10-08		SUZ58035	350						
SWIFT		1.5L Petrol	Man	10-08		SUZ58037	351						
SWIFT	CINO	1.3L Petrol	Man	05-94	06-00	SUZ58110	215						
SWIFT	EZ	1.5L Petrol	Man	02-05	12-07	SUZ58037	351						
SWIFT	EZ	1.6L Petrol	Man	09-06		SUZ58037	351			CNX0230		RDx0070	
SWIFT	SA	1.3L Petrol	Man	01-85	02-87	SUZ58110	215					RDx086	
SWIFT	SF	1.3L Petrol	Man	01-89	06-00	SUZ58110	215					RDx086	RDx283
SWIFT	SF	1.6L Petrol	Auto	10-89	04-96	H7CA	350					RDx283	
SWIFT	SF	1.6L Petrol	Man	10-89	04-96	H7CA	350					RDx283	
SX4		2.0L Petrol	Auto	08-08		H63CA	351	SUZ1227	351	CNX845			
SX4		2.0L Petrol	Man	08-08		H62CM	351	SUZ1227	351	CNX845			
SX4	ADVENTURE	2.0L Petrol	Auto	10-08	01-09	H63CA	351	SUZ1227	351	CNX845			
SX4	ADVENTURE	2.0L Petrol	Man	10-08	01-09	H62CM	351	SUZ1227	351	CNX845			
SX4	GY	2.0L Petrol	Auto	08-07		H63CA	351	SUZ1227	351	CNX845			
SX4	GY	2.0L Petrol	Man	02-07	08-08	SUZ1227	351	G28CA	275	CNX845			
SX4	GY	2.0L Petrol	Man	08-07		H62CM	351	SUZ1227	351	CNX845			
VITARA	SE416	1.6L Petrol	Auto	08-89	07-95	H32CA	352	SUZ58002	347	CNX845		RDx086	
VITARA	SE416	1.6L Petrol	Man	07-88	10-95	SUZ58004	353					RDx086	
VITARA	SE416C	1.6L Petrol	Auto	01-95	12-95	H32CA	352						

MODEL	SERIES	ENGINE	TRANS	YEAR FROM	YEAR TO	RADIATOR OPTION 1	PAGE	RADIATOR OPTION 2	PAGE	CONDENSER OPTION 1	CONDENSER OPTION 2	RECEIVER DRIER OPTION 1	RECEIVER DRIER OPTION 2
SUZUKI (continued)													
VITARA	SE416C	1.6L Petrol	Man	01-95	12-95	H32CM	352						
VITARA	SE416L1	1.6L Petrol	Man	01-97	12-97	H32CM	352						
VITARA	SE416QU	1.6L Petrol	Man	01-97	12-97	H32CM	352						
VITARA	SE416V	1.6L Petrol	Auto	01-95	12-95	H32CA	352						
VITARA	SE416W	1.6L Petrol	Man	01-95	12-95	H32CM	352						
VITARA	SE416W	1.6L Petrol	Auto	01-91	01-94	H32CA	352						
VITARA	SE416W	1.6L Petrol	Man	01-95	01-96	H32CM	352						
VITARA	SE416W	1.6L Petrol	Man	01-97	01-98	H32CM	352						
VITARA	SV-SQ420	2.0L Petrol	Auto	05-97	05-99	H24CA	347						
VITARA	SV-SQ420	2.0L Petrol	Man	05-97	05-99	H24CM	352	H36CM	348				
VITARA	SV620	2.0L Petrol	Auto	03-95	04-99	H23CA	348	SUZ58020	347			RDx281	
VITARA	SV620	2.0L Petrol	Man	03-95	04-99	H23CM	348	SUZ58020	347			RDx281	
VITARA	SZ416	1.6L Petrol	Auto	08-91	04-98	H32CA	352	SUZ58002	347			RDx086	RDx281
VITARA	SZ416	1.6L Petrol	Man	08-91	04-98	H32CM	352	SUZ58020	347			RDx086	RDx281
TOYOTA													
4-RUNNER	LN130	2.8L Diesel	Man	11-89	07-96	TOY61209	354			CNX1910			RDx282
4-RUNNER	LN60	2.4L Diesel	Man	08-84	10-86	TOY61163	354			CNX064			RDx086
4-RUNNER	LN61	2.4L Diesel	Man	12-85	09-89	TOY61163	354						RDx086
4-RUNNER	LN61	2.8L Diesel	Man	12-85	09-90	TOY61209	354						RDx086
4-RUNNER	RN130	2.4L Petrol	Auto	10-90	06-96	TOY61162	354			CNX1290			RDx282
4-RUNNER	RN130	2.4L Petrol	Man	10-89	06-96	TOY61162	354			CNX1910			RDx282
4-RUNNER	VZN130	3.0L Petrol	Auto	10-90	07-96	TOY61159	353			CNX1910			RDx282
4-RUNNER	VZN130	3.0L Petrol	Man	10-90	07-96	TOY61159	353			CNX1910			RDx282
4-RUNNER	YN130	2.2L Petrol	Auto	11-89	12-90	TOY61162	354						RDx282

MODEL	SERIES	ENGINE	TRANS	YEAR FROM	YEAR TO	RADIATOR OPTION 1	PAGE	RADIATOR OPTION 2	PAGE	CONDENSER OPTION 1	CONDENSER OPTION 2	RECEIVER DRIER OPTION 1	RECEIVER DRIER OPTION 2
ALTEZA (NZ)		2.0L Petrol	Auto	01-98	12-04	E80CA	266						
AURION	GSV40R	3.5L Petrol	Auto	10-06		E114CA	354			CNX1170		RDX0070	
AURION TRD	GSV40R	3.5L Petrol	Auto	08-07	09-09	E114CA	354						
AVALON	MCX10R	3.0L Petrol	Auto	07-00	03-06	TOY60070	265	E70CA	265	CNX1580		RDX281	
AVENTIS	ACM20R	2.0L Petrol	Auto	12-01	11-03	E89CM	355			CNX3200		RDX0040	
AVENTIS	ACM20R	2.0L Petrol	Man	12-01	08-02	E89CM	355			CNX3200		RDX0040	
AVENTIS	ACM21R	2.4L Petrol	Auto	11-03		E89CM	355						
CALDINA (NZ)		2.0L Petrol	Auto	01-92	12-98	E85CA	355						
CALDINA (NZ)		2.0L Diesel	Auto	01-92	12-98	E85CA	355						
CALDINA (NZ)	ST215	2.0L Petrol	Auto	01-92	01-96	E85CA	355						
CALDINA (NZ)	ST215	2.0L Turbo Petrol	Man	01-92	01-03	E85CA	355						
CALDINA (NZ)	ST215	2.0L Petrol	Man	01-92	01-96	E85CA	355						
CALDINA (NZ)	ST246	2.0L Turbo Petrol	Auto	09-02	12-04	E85CA	355						
CAMRY	ACV36R	2.4L Petrol	Auto	09-02	07-06	E90CA	356	TOY60272	356	CNX8120		RDX0070	
CAMRY	ACV36R	2.4L Petrol	Man	09-02	07-06	E90CM	355	TOY60272	356	CNX8120		RDX0070	
CAMRY	ACV40R	2.4L Petrol	Auto	07-06		E113CA	355			CNX1170		RDX0070	
CAMRY	ACV40R	2.4L Petrol	Man	07-06		E113CM	355			CNX1170		RDX0070	
CAMRY	MCV20R	3.0L Petrol	Auto	08-97	09-02	TOY60270	265	E32CA	265	CNX8110		RDX281	
CAMRY	MCV20R	3.0L Petrol	Man	08-97	09-02	TOY60270	265	E32CA	265	CNX8110		RDX281	
CAMRY	MCV36R	3.0L Petrol	Auto	09-02	07-06	E91CA	356			CNX8120		RDX0070	
CAMRY	MCV36R	3.0L Petrol	Man	09-02	07-06	E91CM	356			CNX8120		RDX0070	
CAMRY	SDV10	2.2L Petrol	Auto	02-93	12-95	TOY60230	211	15-TOY60230	211	CNX055		RDX281	
CAMRY	SDV10	2.2L Petrol	Man	02-93	12-95	TOY60230	211	15-TOY60230	211	CNX055		RDX281	
CAMRY	SV20	1.8L Petrol	Auto	05-87	08-89	TOY60226	211			CNX051		RDX161	
CAMRY	SV20	1.8L Petrol	Man	05-87	08-89	TOY60228	211			CNX051		RDX161	
CAMRY	SV21	2.0L Petrol	Auto	05-87	02-93	TOY60226	211			CNX051		RDX161	

MODEL	SERIES	ENGINE	TRANS	YEAR FROM	YEAR TO	RADIATOR OPTION 1	PAGE	RADIATOR OPTION 2	PAGE	CONDENSER OPTION 1	CONDENSER OPTION 2	RECEIVER DRIER OPTION 1	RECEIVER DRIER OPTION 2
TOYOTA (continued)													
CAMRY	SV21	2.0L Petrol	Man	05-87	02-93	TOY60228	211			CNX051			RDY161
CAMRY	SV22	2.0L Petrol	Auto	09-89	03-92	TOY60226	211			CNX051			RDY161
CAMRY	SV22	2.0L Petrol	Man	09-89	03-92	TOY60228	211			CNX051			RDY161
CAMRY	SVX10	2.2L Petrol	Auto	02-93	05-98	TOY60230	211	15-TOY60230	211	CNX055			RDY281
CAMRY	SVX10	2.2L Petrol	Man	02-93	05-98	TOY60230	211	15-TOY60230	211	CNX055			RDY281
CAMRY	SVX20R	2.2L Petrol	Auto	08-97	09-02	TOY60260	357	E31CA	357	CNX8110			RDY281
CAMRY	SVX20R	2.2L Petrol	Man	08-97	09-02	TOY60260	357	E31CA	357	CNX8110			RDY281
CAMRY	VCV10R	3.0L Petrol	Auto	04-97	08-97	TOY60232	211			CNX055			RDY281
CAMRY	VCV10R	3.0L Petrol	Man	04-97	08-97	TOY60232	211			CNX055			RDY281
CAMRY	VDV10	3.0L Petrol	Auto	02-93	12-95	TOY60232	211			CNX055			RDY281
CAMRY	XV10	2.2L Petrol	Auto	01-93	12-93	TOY60230	211	15-TOY60230	211	CNX055			RDY281
CAMRY	XV10	2.2L Petrol	Man	02-93	01-96	TOY60230	211	15-TOY60230	211	CNX055			RDY281
CAMRY VIENTA	XV10	3.0L Petrol	Auto	02-93	01-95	TOY60232	211			CNX055			
CARIB		1.6L Petrol	Auto	01-96	12-01	E52CA	363						
CELICA		2.0L Petrol	Auto	01-93	12-99	E37CA	358			CNX5850			
CELICA	RA60	2.0L Petrol	Auto	11-81	10-83	TOY60051	359						RDY086
CELICA	RA60	2.0L Petrol	Man	11-81	10-83	TOY60051	359						RDY086
CELICA	RA65	2.4L Petrol	Auto	10-84	12-85	TOY60051	359						RDY086
CELICA	SA63	2.0L Petrol	Auto	10-83	10-84	TOY60051	359						RDY086
CELICA	SA63	2.0L Petrol	Man	10-83	10-84	TOY60051	359						RDY086
CELICA	ST184	2.2L Petrol	Auto	09-89	02-95	TOY1083	358						RDY282
CELICA	ST184	2.2L Petrol	Man	12-89	02-95	TOY1083	358	E36CM	359				RDY282
CELICA	ST204	2.2L Petrol	Auto	02-94	11-99	E37CA	358						RDY281
CELICA	ST204	2.2L Petrol	Man	02-94	11-99	E37CA	358						RDY281
CELICA	ST214	2.2L Petrol	Auto	03-94	11-99	E37CA	358						
CELICA	ST214	2.2L Petrol	Man	03-94	11-99	E37CA	358						

MODEL	SERIES	ENGINE	TRANS	YEAR FROM	YEAR TO	RADIATOR OPTION 1	PAGE	RADIATOR OPTION 2	PAGE	CONDENSER OPTION 1	CONDENSER OPTION 2	RECEIVER DRIER OPTION 1	RECEIVER DRIER OPTION 2
CELICA	ZT231	1.8L Petrol	Auto	11-99	01-06	TOY60063	358		358	CNX1110		RDX0040	
CELICA	ZT231	1.8L Petrol	Man	11-99	01-06	TOY60063	358	E63CM	358	CNX1110		RDX0040	
COROLLA		1.8L Petrol	Auto	11-78	01-80	TOY60010	362					RDX086	
COROLLA		1.3L Petrol	Auto	01-92	12-97	TOY60218	228	15-TOY60218	228				
COROLLA		1.3L Petrol	Auto	01-92	12-97	TOY60218	228	15-TOY60218	228				
COROLLA		1.3L Petrol	Auto	01-85	12-88	TOY60210	362					RDX086	
COROLLA		1.3L Petrol	Man	01-80	01-84	TOY60010	362					RDX086	
COROLLA		1.3L Petrol	Man	01-87	12-92	TOY60216	228			CNX056	CNX059	RDX284	RDX282
COROLLA		1.5L Petrol	Auto	01-91	12-00	E52CA	363						
COROLLA		1.5L Petrol	Auto	01-95	12-00	E52CA	363						
COROLLA		1.5L Petrol	Auto	01-87	12-92	TOY60214	228	15-TOY60214	228	CNX056	CNX059	RDX284	RDX282
COROLLA		1.5L Petrol	Man	01-91	12-00	TOY60252	363						
COROLLA		1.6L Petrol	Auto	01-91	12-94	TOY60218	228	15-TOY60218	228				
COROLLA		1.6L Petrol	Auto	01-91	12-94	TOY60218	228	15-TOY60218	228				
COROLLA		1.6L Petrol	Auto	01-95	12-01	E52CA	363						
COROLLA		1.6L Petrol	Auto	01-95	12-01	E52CA	363						
COROLLA		1.6L Petrol	Man	01-84	01-86	TOY60010	362					RDX086	
COROLLA		1.6L Petrol	Man	01-91	12-94	TOY60220	228						
COROLLA		1.6L Petrol	Man	01-95	12-01	TOY60252	363						
COROLLA		1.8L Petrol	Auto	01-00	12-04	TOY60087	360						
COROLLA		1.8L Petrol	Auto	01-00	12-04	TOY60087	360						
COROLLA		1.8L Petrol	Auto	01-01	12-06	TOY60087	360						
COROLLA		1.8L Petrol	Auto	01-01	12-06	TOY60087	360						
COROLLA	AE101	1.6L Petrol	Auto	09-94	11-99	TOY60218	228	E29CA2	227	CNX4640		RDX604	
COROLLA	AE101	1.6L Petrol	Man	09-94	11-99	TOY60220	228					RDX604	
COROLLA	AE102	1.8L Petrol	Auto	09-94	11-99	TOY60218	228	E29CA2	227	CNX4640		RDX604	
COROLLA	AE102	1.8L Petrol	Man	09-94	11-99	TOY60220	228					RDX604	
COROLLA	AE111	1.6L Petrol	Auto	01-95	12-00	E52CA	363						

MODEL	SERIES	ENGINE	TRANS	YEAR FROM	YEAR TO	RADIATOR OPTION 1	PAGE	RADIATOR OPTION 2	PAGE	CONDENSER OPTION 1	CONDENSER OPTION 2	RECEIVER DRIER OPTION 1	RECEIVER DRIER OPTION 2
TOYOTA (continued)													
COROLLA	AE111	1.6L Petrol	Man	01-95	12-00	TOY60252	363						
COROLLA	AE112	1.8L Petrol	Auto	10-98	12-01	E52CA	363			CNX4860		RDx604	
COROLLA	AE112	1.8L Turbo Petrol	Man	03-01	11-01	TOY60252	363			CNX4860		RDx604	
COROLLA	AE112	1.8L Petrol	Man	10-98	12-01	TOY60252	363			CNX4860		RDx604	
COROLLA	AE71	1.6L Petrol	Auto	10-83	09-85	TOY60010	362					RDx086	
COROLLA	AE71	1.6L Petrol	Man	10-81	04-86	TOY60010	362					RDx086	
COROLLA	AE80	1.3L Petrol	Auto	09-85	05-90	TOY60101	362	TOY60210	362			RDx086	
COROLLA	AE80	1.3L Petrol	Man	09-85	05-90	TOY60212	362					RDx086	
COROLLA	AE80	1.6L Petrol	Man	04-85	01-87	TOY60212	362					RDx086	
COROLLA	AE82	1.6L Petrol	Auto	09-85	05-90	TOY60101	362	TOY60210	362			RDx086	
COROLLA	AE82	1.6L Petrol	Auto	09-85	05-89	TOY60210	362					RDx086	
COROLLA	AE82	1.6L Petrol	Man	09-85	05-90	TOY60212	362					RDx086	
COROLLA	AE86	1.6L Petrol	Man	07-83	12-85	TOY60212	362					RDx086	
COROLLA	AE90	1.4L Petrol	Man	01-89	10-92	TOY60216	228			CNX059	CNX056	RDx284	RDx282
COROLLA	AE90	1.6L Petrol	Auto	01-91	12-91	TOY60214	228	15-TOY60214	228	CNX056	CNX059	RDx284	RDx282
COROLLA	AE90	1.6L Petrol	Man	01-91	12-91	TOY60216	228			CNX056	CNX059	RDx284	RDx282
COROLLA	AE92	1.6L Petrol	Auto	01-89	09-94	TOY60214	228	15-TOY60214	228	CNX059	CNX056	RDx284	RDx282
COROLLA	AE92	1.6L Petrol	Man	06-89	09-94	TOY60216	228			CNX056	CNX059	RDx282	RDx284
COROLLA	AE93	1.6L Petrol	Auto	08-91	08-94	TOY60214	228	15-TOY60214	228	CNX056	CNX059	RDx282	RDx284
COROLLA	AE93	1.6L Petrol	Man	01-89	08-94	TOY60216	228			CNX056	CNX059	RDx282	RDx284
COROLLA	AE94	1.6L Petrol	Auto	08-91	01-95	TOY60214	228	15-TOY60214	228	CNX056	CNX1490	RDx282	RDx284
COROLLA	AE94	1.6L Petrol	Man	08-91	01-95	TOY60216	228			CNX056	CNX1490	RDx282	RDx284
COROLLA	AE95	1.6L Petrol	Auto	04-88	09-96	TOY60216	228			CNX056		RDx282	
COROLLA	AE95	1.6L Petrol	Man	04-88	09-96	TOY60214	228	15-TOY60214	228	CNX056	CNX059	RDx282	RDx284
COROLLA	AE96	1.8L Petrol	Auto	10-92	09-94	E28CA	361			CNX056		RDx282	
COROLLA	KE30	1.2L Petrol	Auto	11-74	11-78	TOY60010	362			CNX056		RDx086	

MODEL	SERIES	ENGINE	TRANS	YEAR FROM	YEAR TO	RADIATOR OPTION 1	PAGE	RADIATOR OPTION 2	PAGE	CONDENSER OPTION 1	CONDENSER OPTION 2	RECEIVER DRIER OPTION 1	RECEIVER DRIER OPTION 2
COROLLA	KE30	1.2L Petrol	Auto	11-74	11-78	TOY60010	362		362			RDx086	
COROLLA	KE30	1.2L Petrol	Man	11-74	11-78	TOY60010	362		362			RDx086	
COROLLA	KE35	1.2L Petrol	Auto	02-76	11-78	TOY60010	362		362			RDx086	
COROLLA	KE35	1.2L Petrol	Man	02-76	11-78	TOY60010	362		362			RDx086	
COROLLA	KE36	1.2L Petrol	Auto	11-74	11-78	TOY60010	362		362			RDx086	
COROLLA	KE36	1.2L Petrol	Man	11-74	11-78	TOY60010	362		362			RDx086	
COROLLA	KE38	1.3L Petrol	Man	07-80	10-81	TOY60010	362		362			RDx086	
COROLLA	KE50	1.2L Petrol	Man	03-77	11-78	TOY60010	362		362			RDx086	
COROLLA	KE55	1.3L Petrol	Auto	11-78	10-81	TOY60010	362		362			RDx086	
COROLLA	KE55	1.3L Petrol	Man	11-78	10-81	TOY60010	362		362			RDx086	
COROLLA	KE70	1.3L Petrol	Auto	10-81	09-85	TOY60010	362		362			RDx086	
COROLLA	KE70	1.3L Petrol	Man	01-80	04-86	TOY60010	362		362			RDx086	
COROLLA	SPRINTER	1.8L Petrol	Auto	05-94	05-97	TOY60218	228	E29CA2	227	CNX4640		RDx604	
COROLLA	SPRINTER	1.8L Petrol	Man	05-94	05-97	TOY60218	228	E29CA2	227	CNX4640		RDx604	
COROLLA	ZRE152R	1.8L Petrol	Auto	01-10		TOY09370	359	E118CA	359				
COROLLA	ZRE152R	1.8L Petrol	Man	01-10		TOY09380	360	E118CM	359	CNX1330		RDx0070	
COROLLA	ZRE153R	2.0L Petrol	Auto	01-10		TOY09370	359	E118CA	359				
COROLLA	ZE122R	1.8L Petrol	Auto	09-04	05-08	TOY60087	360	E87CA	360	CNX3170	CNX7930	RDx0040	
COROLLA	ZE122R	1.8L Petrol	Man	12-01	05-05	TOY60088	360	E87CM	360	CNX3170	CNX7930	RDx0040	
COROLLA	ZE123R SPORTIVO	1.8L Petrol	Man	05-03	02-06	TOY60088	360	E87CM	360				
COROLLA SECA	AE92	1.6L Petrol	Auto	08-91	10-92	TOY60214	228	15-TOY60214	228	CNX056	CNX059	RDx282	RDx284
COROLLA SECA	AE92	1.6L Petrol	Man	08-91	10-92	TOY60216	228		228	CNX056	CNX059	RDx282	RDx284
COROLLA SECA	AE93	1.8L Petrol	Auto	10-92	09-94	TOY60214	228	15-TOY60214	228	CNX056	CNX059	RDx282	RDx284
COROLLA SECA	AE93	1.8L Petrol	Man	10-92	09-94	TOY60216	228		228	CNX056	CNX059	RDx282	RDx284
CORONA		2.0L Petrol	Auto	01-92	12-96	E85CA	355						
CORONA	RT104	2.0L Petrol	Auto	03-74	10-79	TOY60040	363						
CORONA	RT104	2.0L Petrol	Man	03-74	10-79	TOY60040	363						
CORONA	RT118	2.0L Petrol	Auto	08-74	12-79	TOY60040	363						
CORONA	RT118	2.0L Petrol	Man	01-74	10-79	TOY60040	363						

MODEL	SERIES	ENGINE	TRANS	YEAR FROM	YEAR TO	RADIATOR OPTION 1	PAGE	RADIATOR OPTION 2	PAGE	CONDENSER OPTION 1	CONDENSER OPTION 2	RECEIVER DRIER OPTION 1	RECEIVER DRIER OPTION 2
TOYOTA (continued)													
CORONA	RT132	2.0L Petrol	Auto	01-79	01-83	TOY60040	363						RDY001
CORONA	RT132	2.0L Petrol	Man	10-79	01-82	TOY60040	363						RDY001
CORONA	RT133	2.0L Petrol	Auto	02-82	11-84	TOY60020	363	TOY60030	363				RDY001
CORONA	RT133	2.0L Petrol	Man	02-82	11-84	TOY60020	363	TOY60030	363				RDY001
CORONA	RT142	2.4L Petrol	Auto	11-84	03-88	TOY60020	363			CNX062			RDY086
CORONA	RT142	2.4L Petrol	Man	11-84	03-88	TOY60020	363			CNX062			RDY086
CORONA	ST141	2.0L Petrol	Auto	08-83	03-88	TOY60020	363			CNX062			RDY086
CORONA	ST141	2.0L Petrol	Man	08-83	03-88	TOY60020	363			CNX062			RDY086
CORONA	ST190 IMPORT	1.8L Petrol	Auto	01-87	12-95	E85CA	355						
CORONA	ST190 IMPORT	1.8L Petrol	Auto	01-92	12-96	E85CA	355						
CORONA	XT130	1.9L Petrol	Auto	10-79	08-83	TOY60030	363						
CORONA	XT130	1.9L Petrol	Man	01-79	08-83	TOY60030	363						
CRESSIDA	MX73	2.8L Petrol	Auto	10-84	10-86	TOY1153	364						RDY086
CRESSIDA	MX83	3.0L Petrol	Auto	10-88	08-93	TOY1094	364						RDY282
DYNA 200	BU142R	4.1L Diesel	Man	08-95	05-03	TOY2392	364						RDY284
DYNA 200	BU212	4.1L Diesel	Man	11-97	05-03	TOY2392	364						RDY281
DYNA 200	BU212R	4.1L Diesel	Man	11-97	05-03	TOY2392	364						RDY281
DYNA 400	BU212R	4.1L Diesel	Man	08-95	05-03	TOY2392	364						RDY281
DYNA 400	BU222R	4.1L Diesel	Man	11-97	05-03	TOY2392	364						
ECHO		1.3L Petrol	Auto	01-99	12-05	TOY60068	364						
ECHO	NCP10R	1.3L Petrol	Auto	09-99	12-05	TOY60068	364	E68CA	364				RDY0040
ECHO	NCP10R	1.3L Petrol	Man	09-99	12-05	TOY60069	364						RDY0040
ECHO	NCP12R	1.5L Petrol	Auto	09-99	10-02	TOY60068	364	E68CA	364	CNX5280			RDY0040
ECHO	NCP12R	1.5L Petrol	Man	09-99	10-02	TOY60069	364			CNX5280			RDY0040
ECHO	NCP13R	1.5L Petrol	Man	03-01	12-05	TOY60069	364			CNX5280			RDY0040
ESTIMA		2.4L Petrol	Auto	01-92	12-00	TOY60172	365						

MODEL	SERIES	ENGINE	TRANS	YEAR FROM	YEAR TO	RADIATOR OPTION 1	PAGE	RADIATOR OPTION 2	PAGE	CONDENSER OPTION 1	CONDENSER OPTION 2	RECEIVER DRIER OPTION 1	RECEIVER DRIER OPTION 2
ESTIMA		2.4L Petrol	Auto	01-92	12-00	TOY60172	365						
ESTIMA		2.4L Petrol	Auto	01-90	12-99	TOY60172	365						
ESTIMA		2.4L Petrol	Auto	01-90	12-99	TOY60172	365						
ESTIMA		2.4L Petrol	Auto	01-92	12-99	TOY60172	365						
ESTIMA		2.4L Petrol	Auto	01-92	12-99	TOY60172	365						
ESTIMA		2.4L Petrol	Auto	01-91	12-97	TOY60172	365						
ESTIMA		2.2L Turbo Diesel	Auto	01-91	12-97	TOY60172	365						
ESTIMA		2.2L Turbo Diesel	Auto	01-91	12-97	TOY60172	365						
HIACE		1.6L Petrol	Auto	04-84	01-86	TOY61000	367						
HIACE		2.4L Petrol	Auto	01-90	01-91	TOY1988	366	TOY1989	366	CNX0290	CNX4850	RDX287	
HIACE		2.5L Turbo Diesel	Auto	03-05	11-06	TOY1871	365			CNX9360		RDX0070	
HIACE		2.5L Turbo Diesel	Man	03-05	11-06	TOY1870	365						
HIACE		2.5L Turbo Diesel	Man	03-05	12-09	TOY1870	365						
HIACE		2.5L Turbo Diesel	Man	03-05	12-09	TOY1870	365						
HIACE		3.0L Turbo Diesel	Auto	11-06		TOY1871	365						
HIACE		3.0L Turbo Diesel	Man	11-06		TOY1870	365			CNX9360			
HIACE		2.5L Turbo Diesel	Auto	03-05	11-06	TOY1871	365			CNX9360		RDX0070	
HIACE		2.5L Turbo Diesel	Man	03-05	11-06	TOY1870	365			CNX9360		RDX0070	
HIACE		3.0L Turbo Diesel	Auto	11-06		TOY1871	365						
HIACE		3.0L Turbo Diesel	Man	11-06		TOY1870	365						
HIACE		2.5L Turbo Diesel	Auto	03-05	11-06	TOY1871	365						
HIACE		2.5L Turbo Diesel	Man	03-05	11-06	TOY1870	365						
HIACE		3.0L Turbo Diesel	Auto	11-06		TOY1871	365						
HIACE		3.0L Turbo Diesel	Man	11-06		TOY1870	365						
HIACE		2.8L Diesel	Man	01-89	10-00	TOY2217	376	TOY61020	367	CNX1040		RDX287	
HIACE		2.8L Diesel	Man	02-89	10-00	TOY61020	367			CNX1040		RDX281	
HIACE		2.8L Diesel	Man	10-89	09-00	TOY61020	367					RDX281	
HIACE		2.4L Petrol	Man	10-95	04-04	E59CM	367			CNX5550		RDX287	
HIACE		2.4L Petrol	Man	08-99	04-04	E59CM	367			CNX5550		RDX287	

MODEL	SERIES	ENGINE	TRANS	YEAR FROM	YEAR TO	RADIATOR OPTION 1	PAGE	RADIATOR OPTION 2	PAGE	CONDENSER OPTION 1	CONDENSER OPTION 2	RECEIVER DRIER OPTION 1	RECEIVER DRIER OPTION 2
TOYOTA (continued)													
HIACE	RH11R	1.6L Petrol	Man	01-72	12-85	TOY61000	367						
HIACE	RH20	1.6L Petrol	Man	01-71	01-83	TOY61000	367						
HIACE	RH32	2.0L Petrol	Man	01-77	01-83	TOY61000	367						
HIACE	RH42RB	2.0L Petrol	Man	05-77	12-83	TOY61000	367						
HIACE	RZH103R	2.4L Petrol	Auto	10-89	09-98	TOY1988	366	TOY61010	366	CNX1040		RDX281	
HIACE	RZH103R	2.4L Petrol	Man	10-89	09-98	TOY61010	366			CNX1040		RDX281	
HIACE	RZH113R	2.4L Petrol	Auto	09-98	02-05	TOY1988	366	TOY61010	366	CNX0290	CNX4850	RDX281	RDX287
HIACE	RZH113R	2.4L Petrol	Man	09-98	03-05	TOY100CM	366	TOY61010	366	CNX4850	CNX0290	RDX287	
HIACE	RZH113R	2.4L Petrol	Man	10-89	03-05	TOY61010	366			CNX1040		RDX281	
HIACE	RZH125	2.4L Petrol	Man	09-98	03-05	TOY100CM	366	TOY61010	366	CNX0290	CNX4850	RDX287	
HIACE	RZH125	2.4L Petrol	Man	10-89	09-98	TOY61010	366			CNX1040		RDX281	
HIACE	TRH201R	2.7L Petrol	Auto	01-05		TOY1869	365						
HIACE	TRH201R	2.7L Petrol	Man	01-05		TOY1868	366						
HIACE	TRH221R	2.7L Petrol	Man	03-05		TOY1868	366						
HIACE	TRH223R	2.7L Petrol	Auto	03-05		TOY1869	365						
HIACE	TRH223R	2.7L Petrol	Man	03-05		TOY1868	366						
HILUX		2.2L Petrol	Man	01-87	01-88	TOY61165	371	15-TOY61165	372				
HILUX		2.4L Petrol	Man	02-89	01-94	TOY61165	371	TOY61169	371			RDX281	
HILUX		2.4L Turbo Diesel	Man	01-85	12-89	TOY61163	354						
HILUX		3.0L Diesel	Man	11-00	10-02	E76CM	369	E82CM	369				
HILUX	GGN15R	4.0L Petrol	Auto	01-05		E108CA	367			CNX8820		RDX0070	
HILUX	GGN15R	4.0L Petrol	Man	01-05		E107CM	367			CNX8820		RDX0070	
HILUX	GGN25R	4.0L Petrol	Auto	01-05		E108CA	367			CNX8820		RDX0070	
HILUX	GGN25R	4.0L Petrol	Man	01-05		E107CM	367			CNX8820		RDX0070	
HILUX	KUN16R	3.0L Turbo Diesel	Man	01-05		E104CM	368	TOY61193	368	CNX8810		RDX0070	
HILUX	KUN25R	3.0L Turbo Diesel	Man	10-09		E104CM	368	TOY61193	368				

MODEL	SERIES	ENGINE	TRANS	YEAR FROM	YEAR TO	RADIATOR OPTION 1	PAGE	RADIATOR OPTION 2	PAGE	CONDENSER OPTION 1	CONDENSER OPTION 2	RECEIVER DRIER OPTION 1	RECEIVER DRIER OPTION 2
HILUX	KUN26R	3.0L Turbo Diesel	Auto	03-05		E105CA	367	TOY61192	368	CNX8810		RDXX040	
HILUX	KUN26R	3.0L Turbo Diesel	Man	03-05		E104CM	368	TOY61193	368	CNX8810		RDXX040	
HILUX	KZN165	3.0L Turbo Diesel	Man	01-98	03-06	E76CM	369	E82CM	369	CNX806	CNX3820	RDXX281	
HILUX	KZN165	3.0L Turbo Diesel	Man	12-99	10-02	E76CM	369						
HILUX	LN106	2.8L Diesel	Man	10-88	11-97	TOY61209	354					RDXX281	
HILUX	LN107	2.8L Diesel	Man	01-92	10-97	TOY61209	354					RDXX281	
HILUX	LN111	2.8L Diesel	Man	01-93	01-98	TOY61209	354					RDXX281	
HILUX	LN147	3.0L Diesel	Man	10-97	03-06	TOY61182	370	TOY61188	370	CNX0130		RDXX281	
HILUX	LN167	3.0L Diesel	Man	10-96	03-06	TOY61182	370	TOY61188	370	CNX0130		RDXX281	
HILUX	LN172	3.0L Diesel	Man	10-97	03-06	TOY61182	370	TOY61188	370	CNX0130		RDXX281	
HILUX	LN40	2.2L Diesel	Man	01-79	12-85	TOY61152	372					RDXX022	
HILUX	LN46R	2.2L Diesel	Man	11-81	10-86	TOY61152	372					RDXX022	
HILUX	LN55	2.2L Diesel	Man	11-83	02-89	TOY61155	372					RDXX022	
HILUX	LN56	2.4L Diesel	Auto	09-84	09-88	TOY61163	354			CNX063		RDXX086	
HILUX	LN56	2.4L Diesel	Man	09-84	09-88	TOY61155	372					RDXX086	
HILUX	LN65	2.4L Diesel	Man	01-84	10-88	TOY61155	372					RDXX086	
HILUX	LN65R	2.4L Diesel	Man	11-83	10-88	TOY61155	372					RDXX086	
HILUX	LN85	2.4L Diesel	Man	10-88	10-97	TOY61155	372					RDXX282	
HILUX	LN86	2.8L Diesel	Man	01-92	10-97	TOY1155	371	TOY61209	354			RDXX281	
HILUX	RN105	2.4L Petrol	Man	10-88	11-97	TOY61165	371	TOY61169	371			RDXX281	
HILUX	RN106	2.4L Petrol	Man	01-90	01-98	TOY61165	371	TOY61169	371			RDXX281	
HILUX	RN110	2.4L Petrol	Man	10-88	11-97	TOY61165	371	TOY61169	371			RDXX281	
HILUX	RN30R	1.6L Petrol	Man	01-78	10-88	TOY61154	372	TOY61158	372				
HILUX	RN36	2.0L Petrol	Man	04-79	11-81	TOY61154	372	TOY61158	372			RDXX022	
HILUX	RN40R	1.6L Petrol	Man	01-78	01-84	TOY61154	372	TOY61158	372				
HILUX	RN41	2.0L Petrol	Man	01-78	10-83	TOY61154	372	TOY61158	372			RDXX022	
HILUX	RN41R	2.0L Petrol	Man	01-80	12-87	TOY61154	372	TOY61158	372			RDXX022	
HILUX	RN46	2.0L Petrol	Man	04-79	12-86	TOY61154	372	TOY61158	372			RDXX022	

MODEL	SERIES	ENGINE	TRANS	YEAR FROM	YEAR TO	RADIATOR OPTION 1	PAGE	RADIATOR OPTION 2	PAGE	CONDENSER OPTION 1	CONDENSER OPTION 2	RECEIVER DRIER OPTION 1	RECEIVER DRIER OPTION 2
TOYOTA (continued)													
HILUX	RN85	2.4L Petrol	Auto	10-88	10-97	TOY61156	373	TOY61160	372				RDx281
HILUX	RN85	2.4L Petrol	Man	01-89	10-97	TOY61165	371	TOY61169	371				RDx281
HILUX	RN85R	2.4L Petrol	Man	01-88	11-97	TOY61165	371	TOY61169	371				RDx281
HILUX	RN90	2.4L Petrol	Auto	01-88	01-98	TOY61156	373	TOY61160	372				RDx281
HILUX	RN90	2.4L Petrol	Man	01-88	01-98	TOY61165	371	TOY61169	371				RDx281
HILUX	RN90R	2.4L Petrol	Auto	01-89	12-97	TOY61156	373	TOY61160	372				RDx281
HILUX	RN90R	2.4L Petrol	Man	10-88	05-89	TOY61165	371	TOY61169	371				RDx281
HILUX	RZN147R	2.0L Petrol	Man	10-97	10-02	TOY61180	370	E57CM	369	CNX0130			RDx281
HILUX	RZN147R	2.7L Petrol	Man	01-02	01-06	TOY61180	370	E57CM	369				
HILUX	RZN149R	2.7L Petrol	Auto	01-99	09-05	TOY61178	369	E57CA	369	CNX0130	CNX3820		RDx281
HILUX	RZN154	2.7L Petrol	Auto	01-98	03-06	TOY61178	369	E57CA	369	CNX0130	CNX3820		RDx281
HILUX	RZN154	2.7L Petrol	Man	01-98	12-05	TOY61180	370	E57CM	369	CNX0130	CNX3820		RDx281
HILUX	RZN169	2.7L Petrol	Man	10-97	10-02	TOY61180	370	E57CM	369	CNX0130			RDx281
HILUX	RZN174	2.7L Petrol	Man	10-97	10-02	TOY61180	370	E57CM	369	CNX0130			RDx281
HILUX	TGN16R	2.7L Petrol	Man	01-05		E106CM	368	TOY61194	368	CNX8820			RDx0070
HILUX	VZN167R	3.4L Petrol	Auto	10-02	03-06	E93CA	368			CNX3820			RDx284
HILUX	VZN167R	3.4L Petrol	Man	10-02	03-06	E93CM	369			CNX3820			RDx284
HILUX	VZN172R	3.4L Petrol	Man	01-02	01-06	E93CM	369			CNX3820			RDx281
HILUX	YN55	1.6L Petrol	Man	10-78	11-83	TOY61154	372	TOY61158	372				RDx022
HILUX	YN55	1.6L Petrol	Man	12-83	09-87	TOY61165	371	15-TOY61165	372				RDx022
HILUX	YN56	1.8L Petrol	Man	10-87	09-88	TOY61165	371	15-TOY61165	372				RDx022
HILUX	YN57	2.0L Petrol	Auto	01-84	12-87	TOY61156	373						RDx022
HILUX	YN57	2.0L Petrol	Man	01-82	10-88	TOY61165	371	15-TOY61165	372				RDx022
HILUX	YN57R	2.0L Petrol	Auto	11-83	02-89	TOY61156	373						RDx022
HILUX	YN57R	2.0L Petrol	Man	11-83	12-87	TOY61165	371	15-TOY61165	372				RDx022
HILUX	YN58	2.2L Petrol	Man	11-87	09-88	TOY61165	371	15-TOY61165	372				RDx022

MODEL	SERIES	ENGINE	TRANS	YEAR FROM	YEAR TO	RADIATOR OPTION 1	PAGE	RADIATOR OPTION 2	PAGE	CONDENSER OPTION 1	CONDENSER OPTION 2	RECEIVER DRIER OPTION 1	RECEIVER DRIER OPTION 2
HILUX	YN58R	2.2L Petrol	Man	01-88	12-88	TOY61165	371	15-TOY61165	372				
HILUX	YN65R	2.0L Petrol	Man	09-84	10-88	TOY61165	371	15-TOY61165	372			RDX022	
HILUX	YN67	2.2L Petrol	Man	11-85	10-88	TOY61165	371	15-TOY61165	372			RDX022	
HILUX	YN85	1.8L Petrol	Man	01-88	12-94	TOY61165	371	TOY61169	371			RDX022	
HILUX SURF	LN132	2.8L Diesel	Auto	01-92	12-96	TOY61156	373	TOY61160	372				
HILUX SURF	LN132	2.8L Diesel	Man	01-92	12-96	TOY61165	371	TOY61169	371				
HILUX TRD	GGN25R	4.0L Petrol	Auto	04-08	10-08	E108CA	367						
HILUX TRD	GGN25R	4.0L Petrol	Man	04-08	10-08	E107CM	367						
KLUGER	GSU40R	3.5L Petrol	Auto	08-07		E119CA	374			CNX2820		RDX0070	
KLUGER	GSU45R	3.5L Petrol	Auto	08-07		E119CA	374			CNX2820		RDX0070	
KLUGER	MCU28R	3.3L Petrol	Auto	10-03	08-07	E103CA	374	E99CA	374	CNX2890		RDX0040	
LANDCRUISER	BJ42 (3B)	3.4L Diesel	Man	06-80	12-84	TOY61200	378					RDX022	
LANDCRUISER	BJ70	3.4L Diesel	Man	01-85	11-88	TOY61208	377			CNX052		RDX086	
LANDCRUISER	BJ73	3.4L Diesel	Man	01-85	12-91	TOY61208	377			CNX052		RDX086	
LANDCRUISER	BJ74	3.4L Turbo Diesel	Man	11-85	01-91	TOY61208	377					RDX086	
LANDCRUISER	FJ40	3.9L Petrol	Man	01-65	12-84	TOY61204	378						
LANDCRUISER	FJ40	4.2L Petrol	Man	01-72	12-84	TOY61203	378					RDX086	
LANDCRUISER	FJ45	3.9L Petrol	Man	01-67	12-84	TOY61204	378						
LANDCRUISER	FJ45	4.2L Petrol	Man	11-72	12-84	TOY61203	378					RDX086	
LANDCRUISER	FJ55	3.9L Petrol	Man	01-66	11-80	TOY61202	378						
LANDCRUISER	FJ55	4.2L Petrol	Man	11-72	11-80	TOY61202	378					RDX086	
LANDCRUISER	FJ60	4.2L Petrol	Man	11-80	04-90	TOY61205	377					RDX086	
LANDCRUISER	FJ62	4.0L Petrol	Auto	01-85	12-90	TOY61214	377					RDX086	
LANDCRUISER	FJ62	4.0L Petrol	Man	01-85	12-90	TOY61214	377					RDX086	
LANDCRUISER	FJ70	4.0L Petrol	Auto	01-85	09-92	TOY61206	377			CNX052		RDX086	
LANDCRUISER	FJ70	4.0L Petrol	Man	01-85	09-92	TOY61206	377			CNX052		RDX086	
LANDCRUISER	FJ73LX	4.0L Petrol	Man	01-85	11-92	TOY61206	377			CNX052		RDX086	
LANDCRUISER	FJ75	4.0L Petrol	Man	01-85	11-92	TOY61206	377			CNX052		RDX086	

MODEL	SERIES	ENGINE	TRANS	YEAR FROM	YEAR TO	RADIATOR OPTION 1	PAGE	RADIATOR OPTION 2	PAGE	CONDENSER OPTION 1	CONDENSER OPTION 2	RECEIVER DRIER OPTION 1	RECEIVER DRIER OPTION 2
TOYOTA (continued)													
LANDCRUISER	FJ80	4.0L Petrol	Man	12-89	08-92	TOY61220	376			CNX2700			RD282
LANDCRUISER	FZJ105R	4.5L Petrol	Auto	03-98	10-02	TOY61230	375	TOY61240	375	CNX4800			RD282
LANDCRUISER	FZJ105R	4.5L Petrol	Man	03-98	10-02	TOY61232	375	TOY61242	375	CNX4800			RD282
LANDCRUISER	FZJ75	4.5L Petrol	Man	01-85	10-99	TOY61206	377	TOY61211	376	CNX1400			RD282
LANDCRUISER	FZJ80	4.5L Petrol	Auto	05-90	12-98	TOY61216	376	TOY08850	376	CNX072			RD282
LANDCRUISER	HDJ100R	4.2L Turbo Diesel	Auto	10-00	10-02	TOY61230	375	TOY61240	375	CNX7960			RD282
LANDCRUISER	HDJ100R	4.2L Turbo Diesel	Man	10-00	01-08	TOY61232	375	TOY61242	375	CNX7960			RD282
LANDCRUISER	HDJ78R	4.2L Turbo Diesel	Man	11-01	03-07	TOY61217	375			CNX1410			RD282
LANDCRUISER	HDJ79R	4.2L Turbo Diesel	Man	01-01	03-07	TOY61217	375			CNX1410			RD282
LANDCRUISER	HDJ80	4.2L Turbo Diesel	Auto	01-95	03-99	TOY61216	376			CNX072			RD282
LANDCRUISER	HDJ80	4.2L Diesel	Auto	05-90	03-95	TOY61216	376			CNX0830			RD282
LANDCRUISER	HDJ80	4.2L Turbo Diesel	Man	01-95	03-99	TOY61216	376			CNX072			RD282
LANDCRUISER	HDJ80	4.2L Diesel	Man	08-90	03-95	TOY61216	376	TOY61220	376	CNX072			RD282
LANDCRUISER	HJ47	4.0L Diesel	Man	10-80	12-84	TOY61207	377						RD282
LANDCRUISER	HJ60	4.0L Diesel	Man	11-80	04-91	TOY61208	377	TOY61210	377				RD282
LANDCRUISER	HJ61	4.0L Turbo Diesel	Auto	08-87	01-91	TOY61210	377						RD282
LANDCRUISER	HJ61	4.0L Turbo Diesel	Man	01-86	01-91	TOY61214	377						RD282
LANDCRUISER	HJ75	4.0L Diesel	Man	01-85	03-91	TOY61208	377			CNX052			RD282
LANDCRUISER	HZJ105R	4.2L Diesel	Auto	03-98	10-02	TOY61230	375	TOY61240	375	CNX4800			RD282
LANDCRUISER	HZJ105R	4.2L Diesel	Man	03-98	10-02	TOY61232	375	TOY61242	375	CNX4800			RD282
LANDCRUISER	HZJ70	4.2L Diesel	Man	01-90	09-92	TOY61217	375						RD282
LANDCRUISER	HZJ73	4.2L Diesel	Man	03-90	02-91	TOY61215	376						RD282
LANDCRUISER	HZJ75	4.2L Diesel	Man	01-85	10-99	TOY61211	376	TOY61215	376				RD282
LANDCRUISER	HZJ75RP	4.2L Diesel	Man	09-90	12-99	TOY61211	376	TOY61215	376				RD282
LANDCRUISER	HZJ75RPM	4.2L Diesel	Man	09-90	12-90	TOY61211	376	TOY61215	376				RD282
LANDCRUISER	HZJ78R	4.2L Diesel	Man	10-99	03-07	TOY61217	375			CNX1400			RD282

MODEL	SERIES	ENGINE	TRANS	YEAR FROM	YEAR TO	RADIATOR OPTION 1	PAGE	RADIATOR OPTION 2	PAGE	CONDENSER OPTION 1	CONDENSER OPTION 2	RECEIVER DRIER OPTION 1	RECEIVER DRIER OPTION 2
LANDCRUISER	HZJ79R	4.2L Diesel	Man	01-99	03-07	TOY61217	375			CNX1410		RDX284	
LANDCRUISER	HZJ80	4.2L Diesel	Man	11-90	03-99	TOY61216	376	VOL26551	396	CNX072		RDX282	RDX613
LANDCRUISER	PZJ73	3.5L Diesel	Man	03-90	12-92	TOY61215	376					RDX086	
LANDCRUISER	UZJ100R	4.7L Petrol	Auto	03-98	10-00	TOY61260	266			CNX0861		RDX0020	
LANDCRUISER	UZJ100R	4.7L Petrol	Man	10-02	12-07	TOY61260	266			CNX0861		RDX0020	
LANDCRUISER	VDJ200R	4.5L Diesel	Auto	11-07	01-11	TOY1138	374			CNX4401		RDX0040	
LANDCRUISER PRADO	GRJ120R	4.0L Petrol	Auto	02-03	09-04	TOY61272	380	TOY09570	380	CNX9810		RDX0040	
LANDCRUISER PRADO	GRJ120R	4.0L Petrol	Man	02-03	09-04	TOY61272	380	TOY09570	380	CNX9810		RDX0040	
LANDCRUISER PRADO	GRJ150R	4.0L Petrol	Auto	11-09		E121CA	380			CNX6270		RDX0070	
LANDCRUISER PRADO	GRJ150R	4.0L Petrol	Man	11-09		E121CA	380			CNX6270		RDX0070	
LANDCRUISER PRADO	KDJ120R	3.0L Turbo Diesel	Auto	11-06	12-09	E97CA	381					RDX0040	
LANDCRUISER PRADO	KDJ120R	3.0L Turbo Diesel	Man	11-06	12-09	E97CM	381			CNX7730		RDX0050	
LANDCRUISER PRADO	KZJ120R	3.0L Turbo Diesel	Auto	02-03	11-06	E97CA	381			CNX7730		RDX0040	
LANDCRUISER PRADO	KZJ120R	3.0L Turbo Diesel	Man	02-03	11-06	E97CM	381	E98CM	381			RDX0040	
LANDCRUISER PRADO	KZJ95R	3.0L Turbo Diesel	Auto	03-00	12-02	E77CA	381			CNX3070		RDX284	
LANDCRUISER PRADO	KZJ95R	3.0L Turbo Diesel	Man	03-00	12-02	E77CM	382			CNX3070		RDX284	
LANDCRUISER PRADO	RZJ120R	2.7L Petrol	Auto	02-03	09-04	E95CA	381					RDX0040	
LANDCRUISER PRADO	RZJ120R	2.7L Petrol	Man	02-03	09-04	E95CM	381	TOY09581	380			RDX0040	
LANDCRUISER PRADO	RZJ95R	2.7L Petrol	Auto	07-96	10-01	E43CA	382			CNX3070		RDX284	
LANDCRUISER PRADO	RZJ95R	2.7L Petrol	Man	07-96	05-03	E43CA	382			CNX3070		RDX284	
LANDCRUISER PRADO	VZJ95R	3.4L Petrol	Auto	07-96	02-03	E43CA	382			CNX3070		RDX284	
LANDCRUISER PRADO	VZJ95R	3.4L Petrol	Man	07-96	02-03	E43CA	382			CNX3070		RDX284	
LEXGEN	T4	3.8L Petrol	Auto	05-95	06-96	HOL24200	225	15-HOL24200	225	CNX027		RDX101	
LEXGEN	T5	3.8L Petrol	Auto	06-96	08-97	HOL24300	225	15-HOL24300	225	CNX027		RDX101	
LEXGEN	VN	3.8L Petrol	Auto	09-89	11-91	HOL24100	226			CNX027		RDX104	
LEXGEN	VP	3.8L Petrol	Auto	11-91	08-93	HOL24200	225	15-HOL24200	225	CNX027		RDX104	
LEXGEN	VR	3.8L Petrol	Auto	08-93	05-96	HOL24200	225	15-HOL24200	225	CNX027		RDX101	
LUCIDA (NZ)		2.4L Petrol	Auto	01-92	12-99	TOY60172	365						

MODEL	SERIES	ENGINE	TRANS	YEAR FROM	YEAR TO	RADIATOR OPTION 1	PAGE	RADIATOR OPTION 2	PAGE	CONDENSER OPTION 1	CONDENSER OPTION 2	RECEIVER DRIER OPTION 1	RECEIVER DRIER OPTION 2
TOYOTA (continued)													
MR2	SW20	2.0L Petrol	Man	03-90	09-99	E94CM	379					RDX281	
MR2	SW20	2.0L Petrol	Man	03-90	09-99	E94CM	379						
MR2	ZW30R	1.8L Petrol	Man	10-00	10-02	E94CM	379			CNX4080		RDX0040	
PASEO	EL44	1.5L Petrol	Man	06-91	11-95	E45CM	380					RDX282	
PREVIA (NZ)		2.4L Petrol	Auto	01-00	12-05	E78CA	382						
PREVIA (NZ)		2.4L Petrol	Auto	01-90	12-00	TOY60172	365						
PREVIA (NZ)		2.4L Petrol	Auto	01-90	12-00	TOY60172	365						
PRIUS	NHW11R	1.5L Hybrid	Auto	10-01	10-03	E86CA	382					RDX0070	
PRIUS	NHW20R	1.5L Hybrid	Auto	10-03	12-09	E111CA	382			CNX8881		RDX0280	
RAV4	ACA20R	2.0L Petrol	Auto	07-00	09-03	TOY60147	383			CNX2090		RDX0040	
RAV4	ACA21R	2.0L Petrol	Auto	07-00	09-03	TOY60147	383			CNX2090		RDX0040	
RAV4	ACA22R	2.4L Petrol	Auto	09-03	02-06	TOY60147	383			CNX8650		RDX0040	
RAV4	ACA23R	2.4L Petrol	Auto	09-03	02-06	TOY60147	383			CNX8650		RDX0040	
RAV4	ACA33R	2.4L Petrol	Auto	02-06	10-08	TOY1713	383					RDX0050	
RAV4	SXA10R	2.0L Petrol	Auto	07-94	07-00	TOY60140	383	TOY60145	383			RDX281	
RAV4	SXA10R	2.0L Petrol	Man	07-94	07-00	TOY60141	384	TOY60146	383			RDX281	
RAV4	SXA11R	2.0L Petrol	Auto	07-95	07-00	TOY60140	383	TOY60145	383			RDX281	
RAV4	SXA11R	2.0L Petrol	Man	07-95	07-00	TOY60141	384	TOY60146	383			RDX281	
SOARER	JZZ31	3.0L Petrol	Auto	01-90	12-97	E69CA	384						
SOARER	UZZ31	4.0L Petrol	Auto	02-90	12-98	E53CA	384						
SPACIA	SR40R	2.0L Petrol	Auto	01-98	01-02	E59CA	384			CNX7410		RDX287	
SPACIA	SR40R	2.0L Petrol	Man	01-98	01-02	E59CA	384	E59CM	367	CNX7410		RDX287	
SPRINTER		1.5L Petrol	Auto	01-95	12-00	E52CA	363						
SPRINTER		1.5L Petrol	Auto	01-91	12-97	E52CA	363						
SPRINTER		1.5L Petrol	Auto	01-87	12-91	TOY60214	228	15-TOY60214	228	CNX056	CNX059	RDX282	RDX284
SPRINTER		1.6L Petrol	Auto	01-96	12-97	TOY60218	228	15-TOY60218	228				
SPRINTER		1.6L Petrol	Auto	01-96	12-97	TOY60218	228	15-TOY60218	228				

MODEL	SERIES	ENGINE	TRANS	YEAR FROM	YEAR TO	RADIATOR OPTION 1	PAGE	RADIATOR OPTION 2	PAGE	CONDENSER OPTION 1	CONDENSER OPTION 2	RECEIVER DRIER OPTION 1	RECEIVER DRIER OPTION 2
SPRINTER		1.6L Petrol	Auto	01-95	12-00	E52CA	363						
STARLET	EP91R	1.3L Petrol	Auto	03-96	09-99	E54CA	385					RDX284	
STARLET	EP91R	1.3L Petrol	Man	03-96	09-99	E47CM	387					RDX284	
SUPRA	JZA80	3.0L Petrol	Auto	01-93	12-98	E74CA	387						
SUPRA	JZA80	3.0L Turbo Petrol	Auto	01-93	12-98	E74CA	387						
SUPRA	JZA80	3.0L Petrol	Man	01-93	12-98	E74CA	387						
SUPRA	JZA80	3.0L Turbo Petrol	Man	01-93	12-98	E74CA	387						
SURF	SSR, SSR-G, SSR-X	3.0L Turbo Diesel	Auto	01-92	12-97	E79CA	387						
SURF	SSR, SSR-G, SSR-X	3.0L Turbo Diesel	Man	01-92	12-97	E79CA	387						
TARAGO	ACR30R	2.4L Petrol	Auto	06-00	03-07	E78CA	382			CNX1900		RDX0040	
TARAGO	ACR50R	2.4L Petrol	Auto	02-09		TOY1140	387			CNX1000		RDX0070	
TARAGO	GSR50R	3.5L Petrol	Auto	02-07		TOY1140	387			CNX1320		RDX0070	
TARAGO	TCR10	2.4L Petrol	Auto	08-90	06-01	TOY60172	365	E51CA	387	CNX1070			
TARAGO	TCR10	2.4L Petrol	Man	08-90	06-01	TOY60172	365	E51CA	387	CNX1070		RDX287	
TARAGO	TCR11	2.4L Petrol	Auto	08-90	06-01	TOY60172	365	E51CA	387	CNX1070			
TARAGO	TCR11	2.4L Petrol	Man	08-90	06-01	TOY60172	365	E51CA	387	CNX1070			
TARAGO	TCR20	2.4L Petrol	Man	08-90	06-00	TOY60172	365	E51CA	387	CNX1070		RDX287	
TARAGO	TCR21R	2.4L Petrol	Man	01-90	10-93	TOY60172	365	E51CA	387				
TERCEL	AL25	1.5L Petrol	Man	10-83	04-89	TOY1103	386					RDX086	
TOWNACE	KR42	1.8L Petrol	Auto	02-97	04-04	E59CA	384					RDX287	
TOWNACE	KR42	1.8L Petrol	Man	02-97	04-04	E59CM	367					RDX287	
TOWNACE SBV	KR42R	1.8L Petrol	Auto	02-97	04-04	E59CA	384						
TOWNACE SBV	KR42R	1.8L Petrol	Man	02-97	04-04	E59CM	367						
VIENTA	MCV20R	3.0L Petrol	Auto	08-97	09-00	TOY60270	265	E32CA	265	CNX8110		RDX281	
VIENTA	VCV10R	3.0L Petrol	Auto	01-95	08-97	TOY60232	211			CNX055		RDX281	
VIENTA	VCV10R	3.0L Petrol	Man	01-95	08-97	TOY60232	211			CNX055		RDX281	
VIENTA	VDV10	3.0L Petrol	Auto	02-93	04-94	TOY60232	211			CNX055		RDX281	
VIENTA	VZV10	3.0L Petrol	Auto	02-93	05-98	TOY60232	211			CNX055		RDX281	
VIENTA	VZV10	3.0L Petrol	Man	08-95	08-97	TOY60232	211			CNX055		RDX281	

MODEL	SERIES	ENGINE	TRANS	YEAR FROM	YEAR TO	RADIATOR OPTION 1	PAGE	RADIATOR OPTION 2	PAGE	CONDENSER OPTION 1	CONDENSER OPTION 2	RECEIVER DRIER OPTION 1	RECEIVER DRIER OPTION 2
TOYOTA (continued)													
WINDOM (NZ)		3.0L Petrol	Auto	01-91	12-96	TOY60232	211						
YARIS	NCP90R	1.3L Petrol	Auto	10-05	10-08	TOY1481	388			CNX2361		RDX0040	
YARIS	NCP90R	1.3L Petrol	Man	10-05	10-08	TOY1480	388			CNX2361		RDX0040	
YARIS	NCP91R	1.5L Petrol	Auto	10-05	10-08	TOY1481	388			CNX2361		RDX0040	
YARIS	NCP91R	1.5L Petrol	Man	10-05	10-08	TOY1480	388			CNX2361		RDX0040	
YARIS	NCP93R	1.5L Petrol	Auto	03-06	10-08	TOY1481	388			CNX2361		RDX0040	
YARIS	NCP93R	1.5L Petrol	Man	03-06	10-08	TOY1480	388			CNX2361		RDX0040	
VOLKSWAGEN													
BEETLE		1.9L Turbo Diesel	Man	01-05		VW16611	388						
BEETLE		2.0L Petrol	Auto	01-03		VW16611	388						
BEETLE		2.0L Petrol	Man	01-03		VW16611	388						
BEETLE	9C	1.6L Petrol	Man	01-02		VW16611	388	VW32010	388				
BEETLE	9C	2.0L Petrol	Auto	01-00	10-05	VW16611	388			CNX858		RDX378	
BEETLE	9C	2.0L Petrol	Man	01-00	10-05	VW16611	388	VW32010	388	CNX858		RDX378	
BORA		2.0L Petrol	Auto	06-04	11-05	VW13781	159						
BORA		2.0L Petrol	Man	06-04	11-05	VW13781	159						
BORA		2.3L Petrol	Auto	06-04	11-05	VW13781	159						
BORA		2.3L Petrol	Man	01-99	12-03	VW13781	159						
BORA		2.8L Petrol	Man	10-04	11-05	VW13781	159						
BORA	1J	2.0L Petrol	Auto	12-99	06-05	VW13781	159						
BORA	1J	2.0L Petrol	Man	12-99	06-05	VW13781	159						
BORA	1J	2.3L Petrol	Auto	08-01	06-05	VW13781	159						
BORA	1J	2.3L Petrol	Man	12-99	06-05	VW13781	159						
BORA	1J	2.8L Petrol	Man	06-01	06-04	VW13781	159						
BORA	V5	2.3L Petrol	Auto	07-02	12-03	VW13781	159						
CADDY		1.9L Turbo Diesel	Man	01-06	07-08	VW26701	158	VW65121	158			RDX370	

MODEL	SERIES	ENGINE	TRANS	YEAR FROM	YEAR TO	RADIATOR OPTION 1	PAGE	RADIATOR OPTION 2	PAGE	CONDENSER OPTION 1	CONDENSER OPTION 2	RECEIVER DRIER OPTION 1	RECEIVER DRIER OPTION 2
CADDY	LIFE	1.6L Petrol	Man	05-06	07-08	VW81091	159					RDX370	
CADDY	LIFE	1.9L Turbo Diesel	Man	05-06		VW26701	158	VW65121	158			RDX370	
CADDY	MAXI	1.9L Turbo Diesel	Man	01-06	12-10	VW26701	158	VW65121	158				
CADDY	MAXI	1.9L Turbo Diesel	Man	07-08		VW74031	158	VW65121	158	CNX870		RDX370	
CADDY	MAXI LIFE	1.9L Turbo Diesel	Man	01-06		VW26701	158	VW65121	158			RDX370	
CADDY	MAXI LIFE	1.9L Turbo Diesel	Man	07-08		VW74031	158	VW65121	158	CNX870		RDX370	
CADDY VAN		1.6L Petrol	Man	01-05		VW81091	159			CNX884			
CADDY VAN		1.9L Turbo Diesel	Man	01-05		VW26701	158	VW65121	158	CNX884			
EOS	103	2.0L Turbo Diesel	Man	01-07		VW65121	158			CNX870		RDX370	
EOS	147	2.0L Turbo Petrol	Man	08-08		VW74031	158						
EOS	FSI	2.0L Turbo Petrol	Man	03-07	08-08	VW74031	158					RDX370	
EOS	TDI	2.0L Turbo Diesel	Man	03-07		VW65121	158			CNX870		RDX370	
GOLF		1.4L Petrol	Auto	09-10		VW13781	159					RDX370	
GOLF		1.6L Petrol	Auto	01-76	12-76	VW13781	159						
GOLF		1.8L Turbo Petrol	Man	04-99	08-04	VW13781	159			CNX860		RDX908	
GOLF		1.8L Petrol	Man	08-90	10-99	VW14041	391			CNX861		RDX908	
GOLF		2.0L Turbo Petrol	Auto	05-05	08-07	VW74041	158	VW74031	158	CNX881		RDX913	
GOLF		2.0L Turbo Petrol	Man	05-05	08-07	VW74041	158	VW74031	158	CNX881		RDX913	
GOLF	103TDI COMFORTLINE	2.0L Turbo Diesel	Man	02-09		VW74041	158			CNX881		RDX913	
GOLF	118TSI COMFORTLINE	1.4L Petrol	Man	02-09		VW13781	159			CNX881		RDX913	
GOLF	4TH GEN	2.0L Petrol	Auto	04-02	01-04	VW13781	159						
GOLF	4TH GEN	2.0L Petrol	Man	04-02	01-04	VW13781	159					RDX370	
GOLF	77TDI TRENDLINE	1.6L Turbo Diesel	Man	08-09		VW26701	158			CNX881		RDX913	
GOLF	90TSI TRENDLINE	1.4L Turbo Petrol	Man	02-09		VW26701	158			CNX881		RDX913	
GOLF	A5	1.4L Petrol	Man	01-07	05-10	VW26701	158	VW74031	158	CNX881		RDX913	
GOLF	A5	1.6L Petrol	Auto	08-04	12-09	VW81091	159			CNX881		RDX913	
GOLF	A5	1.6L Petrol	Man	08-04	12-09	VW81091	159			CNX881		RDX913	
GOLF	A5	1.9L Turbo Diesel	Man	08-07	04-08	VW26701	158			CNX881		RDX913	

MODEL	SERIES	ENGINE	TRANS	YEAR FROM	YEAR TO	RADIATOR OPTION 1	PAGE	RADIATOR OPTION 2	PAGE	CONDENSER OPTION 1	CONDENSER OPTION 2	RECEIVER DRIER OPTION 1	RECEIVER DRIER OPTION 2
VOLKSWAGEN (continued)													
GOLF	A5	2.0L Petrol	Auto	08-07	10-08	VW81091	159			CNX881			RDx913
GOLF	A5	2.0L Petrol	Man	08-07	10-08	VW81091	159			CNX881			RDx913
GOLF	A5	2.0L Turbo Diesel	Man	08-07	10-08	VW74041	158			CNX881			RDx913
GOLF	A5	2.0L Turbo Petrol	Man	08-07	10-08	VW74041	158	VW74031	158	CNX881			RDx913
GOLF	A5	2.0L Petrol	Man	10-08	03-09	VW81091	159			CNX881			RDx913
GOLF	A5	2.0L Turbo Diesel	Man	10-08	03-10	VW74041	158			CNX881			RDx913
GOLF	CL	1.8L Petrol	Auto	06-93	11-99	VW13781	159			CNX861			RDx908
GOLF	CL	1.8L Petrol	Auto	10-95	10-96	VW14041	391			CNX861			RDx908
GOLF	CL	1.8L Petrol	Man	08-90	11-99	VW13301	390			CNX861			RDx908
GOLF	CL	1.8L Petrol	Man	10-95	10-96	VW14041	391			CNX861			RDx908
GOLF	COMFORT-TRED	1.6L Petrol	Auto	08-07	04-08	VW81091	159			CNX861			RDx908
GOLF	COMFORT-TRED	1.6L Petrol	Man	08-07	04-08	VW81091	159			CNX861			RDx908
GOLF	FSI COMFORTLINE	2.0L Petrol	Auto	08-04	07-08	VW81091	159			CNX861			RDx908
GOLF	FSI COMFORTLINE	2.0L Petrol	Man	08-04	07-08	VW81091	159			CNX861			RDx908
GOLF	FSI SPORTLINE	2.0L Petrol	Auto	08-04	08-07	VW81091	159			CNX861			RDx908
GOLF	FSI SPORTLINE	2.0L Petrol	Man	08-04	08-07	VW81091	159			CNX861			RDx908
GOLF	GENERATION	1.6L Petrol	Auto	10-01	08-04	VW81091	159						
GOLF	GENERATION	1.6L Petrol	Man	10-01	08-04	VW81091	159			CNX881			RDx913
GOLF	GENERATION	2.0L Petrol	Auto	06-03	08-04	VW13781	159			CNX861			RDx908
GOLF	GENERATION	2.0L Petrol	Man	06-03	08-04	VW13781	159			CNX861			RDx908
GOLF	GL	1.6L Petrol	Auto	10-98	03-03	VW13781	159			CNX861			RDx908
GOLF	GL	1.6L Petrol	Man	10-98	03-03	VW13781	159			CNX861			RDx908
GOLF	GL	2.0L Petrol	Auto	07-94	07-00	VW14041	391			CNX861			RDx908
GOLF	GL	2.0L Petrol	Man	03-95	02-04	VW14041	391			CNX861			RDx908
GOLF	GL RALLY	1.6L Petrol	Auto	10-99	07-01	VW13781	159						
GOLF	GL RALLY	1.6L Petrol	Man	10-99	07-01	VW13781	159						
GOLF	GL TDi	1.9L Turbo Diesel	Auto	10-95	05-98	VW14041	391			CNX861			RDx908
GOLF	GL TDi	1.9L Turbo Diesel	Man	10-95	05-98	VW14041	391			CNX861			RDx908

MODEL	SERIES	ENGINE	TRANS	YEAR FROM	YEAR TO	RADIATOR OPTION 1	PAGE	RADIATOR OPTION 2	PAGE	CONDENSER OPTION 1	CONDENSER OPTION 2	RECEIVER DRIER OPTION 1	RECEIVER DRIER OPTION 2
GOLF	GLE	2.0L Petrol	Auto	11-98	03-02	VW13781	159		159	CNX861		RDx908	
GOLF	GLE	2.0L Petrol	Man	11-98	03-02	VW13781	159		159	CNX861		RDx908	
GOLF	GT	1.4L Petrol	Auto	05-07	08-07	VW74031	158		158	CNX881		RDx913	
GOLF	GT	1.4L Petrol	Man	05-07	08-07	VW26701	158	VW74031	158	CNX881		RDx913	
GOLF	S-SE	1.6L Petrol	Auto	03-02	05-04	VW13781	159		159				
GOLF	S-SE	1.6L Petrol	Man	03-02	12-04	VW13781	159		159				
GOLF	TDI COMFORTLINE	1.9L Turbo Diesel	Auto	08-04	08-07	VW26701	158	VW65121	158	CNX861		RDx908	
GOLF	TDI COMFORTLINE	1.9L Turbo Diesel	Man	08-04	07-08	VW26701	158		158	CNX861		RDx908	
GOLF	TDI COMFORTLINE	2.0L Turbo Diesel	Auto	08-04	08-07	VW74041	158		158	CNX861		RDx908	
GOLF	TDI COMFORTLINE	2.0L Turbo Diesel	Man	08-04	07-08	VW74041	158		158	CNX861		RDx908	
GOLF	TDI TRENDLINE	1.9L Turbo Diesel	Man	08-04	12-09	VW26701	158		158	CNX861		RDx908	
GOLF	V	2.0L Petrol	Auto	01-08	01-10	VW81091	159		159				
GOLF	V	2.0L Petrol	Man	01-08	01-10	VW81091	159		159			RDx370	
GOLF	V	2.0L Turbo Petrol	Man	08-07	01-10	VW74041	158	VW74031	158			RDx370	
GOLF	VR6	2.8L Petrol	Man	03-94	10-98	VW14541	335			CNX861		RDx908	
JETTA	1KM	2.0L Petrol	Auto	02-06	02-09	VW81091	159		159			RDx370	
JETTA	1KM	2.0L Turbo Diesel	Auto	02-06	02-09	VW74041	158		158			RDx370	
JETTA	1KM	2.0L Turbo Petrol	Auto	02-06	02-09	VW74041	158	VW74031	158			RDx370	
JETTA	1KM	2.0L Turbo Petrol	Man	01-06	02-09	VW74041	158		158			RDx370	
JETTA	1KM	2.0L Petrol	Man	02-06	02-09	VW81091	159		159			RDx370	
JETTA	1KM	2.0L Turbo Diesel	Man	02-06	02-10	VW74041	158		158			RDx370	
LT35		2.5L Turbo Diesel	Man	04-03	02-07	VW19701	392		392	CNX854			
LT35		2.8L Turbo Diesel	Man	04-03	02-07	VW19701	392		392	CNX854			
LT46		2.5L Turbo Diesel	Man	04-03	02-07	VW19701	392		392	CNX854			
LT46		2.8L Turbo Diesel	Man	04-03	02-07	VW19701	392		392	CNX854			
MULTIVAN	T5	2.5L Turbo Diesel	Auto	01-04		VW19161	393		393				
MULTIVAN	T5	2.5L Turbo Diesel	Man	01-04		VW19161	393		393				
MULTIVAN	T5	3.2L Petrol	Auto	01-04		VW19171	394		394				

MODEL	SERIES	ENGINE	TRANS	YEAR FROM	YEAR TO	RADIATOR OPTION 1	PAGE	RADIATOR OPTION 2	PAGE	CONDENSER OPTION 1	CONDENSER OPTION 2	RECEIVER DRIER OPTION 1	RECEIVER DRIER OPTION 2
VOLKSWAGEN (continued)													
MULTIVAN	T5	3.2L Petrol	Man	04-05	06-07	VW19171	394						
NEW BEETLE		1.9L Turbo Diesel	Man	11-05	08-07	VW16611	388	VW26701	158				
NEW BEETLE	9C	1.6L Petrol	Auto	10-04	04-08	VW16611	388						
NEW BEETLE	9C	1.6L Petrol	Man	10-04		VW16611	388						
NEW BEETLE	9C	2.0L Petrol	Auto	06-03	08-07	VW16611	388					RDX378	
NEW BEETLE	9C	2.0L Petrol	Man	06-03	08-07	VW16611	388					RDX378	
PASSAT		2.8L Petrol	Man	08-95	04-98	VW14541	335			CNX859		RDX905	
PASSAT	3B	1.8L Petrol	Man	03-98	03-01	AUD16621	159	VW20591	159	CNX869		RDX6549	
PASSAT	3B	1.8L Turbo Petrol	Man	03-98	11-02	AUD16621	159	VW20591	159	CNX869		RDX6549	
PASSAT	GP	1.8L Turbo Petrol	Man	01-02	12-02	AUD16621	159	VW20591	159			RDX6549	
POLLO		1.4L Petrol	Auto	01-02	08-07	VW17701	393			CNX875		RDX6806	
POLLO		1.4L Petrol	Auto	01-07		VW81091	159			CNX875		RDX6806	
POLLO		1.4L Petrol	Man	01-02	11-05	VW17701	393	VW26701	158	CNX875		RDX6806	
POLLO		1.6L Petrol	Auto	01-06		VW17701	393			CNX875		RDX373	
POLLO		1.6L Petrol	Man	01-06		VW17701	393			CNX875		RDX373	
POLLO	6N	1.4L Petrol	Auto	09-00	09-03	VW17701	393			CNX882		RDX6806	
POLLO	6N	1.4L Petrol	Man	09-00	09-03	VW17701	393			CNX882		RDX6806	
POLLO	9N	1.4L Petrol	Man	07-02	09-03	VW17701	393			CNX875		RDX6806	
POLLO	9N	1.9L Turbo Diesel	Man	10-05	08-07	VW17701	393					RDX373	
TIGUAN	103	2.0L Turbo Diesel	Auto	08-08		VW74041	158			CNX881		RDX913	
TIGUAN	103	2.0L Turbo Diesel	Man	08-08		VW74041	158			CNX881		RDX913	
TIGUAN	125	2.0L Turbo Petrol	Auto	08-08		VW74041	158			CNX881		RDX913	
TIGUAN	125	2.0L Turbo Petrol	Man	08-08		VW74041	158			CNX881		RDX913	
TIGUAN	147	2.0L Turbo Petrol	Auto	08-08		VW74041	158			CNX881		RDX913	
TIGUAN		2.0L Turbo Petrol	Auto	05-08	08-08	VW74041	158			CNX881		RDX913	
TIGUAN		2.0L Turbo Diesel	Auto	05-08	08-09	VW74041	158			CNX881		RDX913	
TIGUAN		2.0L Turbo Diesel	Man	05-08	08-09	VW74041	158			CNX881		RDX913	

MODEL	SERIES	ENGINE	TRANS	YEAR FROM	YEAR TO	RADIATOR OPTION 1	PAGE	RADIATOR OPTION 2	PAGE	CONDENSER OPTION 1	CONDENSER OPTION 2	RECEIVER DRIER OPTION 1	RECEIVER DRIER OPTION 2
TIGUAN	5N	2.0L Turbo Petrol	Man	05-08	08-09	VW74041	158			CNX881		RDx913	
TOUAREG		3.0L Turbo Diesel	Auto	08-08		AUD19001	164			CNX910		RDx922	
TOUAREG		3.6L Petrol	Auto	09-06		AUD19001	164			CNX910		RDx922	
TOUAREG		4.2L Petrol	Auto	09-03	09-06	AUD19001	164			CNX910		RDx922	
TOUAREG	TDI	3.0L Turbo Diesel	Auto	09-06	08-08	AUD19001	164			CNX910		RDx922	
TRANSPORTER		2.5L Turbo Diesel	Man	12-94	09-04	VW19161	393						
TRANSPORTER	KOMBI			01-90	01-92	VW13631	394						
TRANSPORTER	KOMBI		Auto	01-79	11-86	VW13631	394						
TRANSPORTER	KOMBI		Man	01-84	11-86	VW13631	394						
TRANSPORTER	KOMBI		Man	01-88	01-92	VW13631	394						
TRANSPORTER	KOMBI	2.1L Petrol	Auto	11-86	12-92	VW13631	394						
TRANSPORTER	KOMBI	2.1L Petrol	Man	11-86	12-92	VW13631	394						
TRANSPORTER	KOMBI SYNCRO			05-89	12-92	VW13631	394						
TRANSPORTER	T3	1.9L Petrol	Auto	01-84	01-87	VW13631	394						
TRANSPORTER	T3	1.9L Petrol	Man	01-84	01-87	VW13631	394						
TRANSPORTER	T3	2.1L Petrol	Auto	01-88	01-90	VW13631	394						
TRANSPORTER	T3	2.1L Petrol	Auto	01-89	12-89	VW13631	394						
TRANSPORTER	T3	2.1L Petrol	Auto	01-90	12-92	VW13631	394						
TRANSPORTER	T3	2.1L Petrol	Auto	01-91	12-92	VW13631	394						
TRANSPORTER	T3	2.1L Petrol	Man	01-88	01-90	VW13631	394						
TRANSPORTER	T4	2.0L Petrol	Man	01-93	09-04	VW14481	394	VW73771	394	CNX5810		RDx281	
TRANSPORTER	T4	2.4L Diesel	Man	01-94	01-98	VW14481	394	VW73771	394	CNX5810		RDx281	
TRANSPORTER	T4	2.5L Petrol	Man	12-94	09-04	VW14481	394	VW73771	394			RDx281	
TRANSPORTER	T5	1.9L Turbo Diesel	Man	01-04	07-08	VW19181	393			CNX878			
TRANSPORTER	T5	2.0L Petrol	Man	08-04		VW19181	393	VW19181	393				
TRANSPORTER	T5	2.5L Turbo Diesel	Auto	08-04	06-08	VW19161	393						
TRANSPORTER	T5	2.5L Turbo Diesel	Man	09-04	06-08	VW19161	393						
TRANSPORTER	T5	3.2L Petrol	Auto	09-04	06-08	VW19171	394						
TRANSPORTER	T5 TDI	1.9L Turbo Diesel	Man	07-08		VW19181	393						

MODEL	SERIES	ENGINE	TRANS	YEAR FROM	YEAR TO	RADIATOR OPTION 1	PAGE	RADIATOR OPTION 2	PAGE	CONDENSER OPTION 1	CONDENSER OPTION 2	RECEIVER DRIER OPTION 1	RECEIVER DRIER OPTION 2
VOLKSWAGEN (continued)													
TRANSPORTER	T5 TDI	2.5L Turbo Diesel	Auto	07-08		VW19161	393						
TRANSPORTER	T5 TDI	2.5L Turbo Diesel	Man	07-08		VW19161	393						
TRANSPORTER CREWMAN	T5	2.5L Turbo Diesel	Auto	08-06		VW19161	393						
TRANSPORTER CREWMAN	T5	2.5L Turbo Diesel	Man	06-07		VW19161	393						
VOLVO													
240		2.1L Petrol	Auto	02-83	12-84	VOL62100	394						RDx027
240		2.3L Petrol	Auto	02-83	06-91	VOL62100	394						RDx027
240		2.3L Petrol	Man	01-89	01-90	VOL62100	394						RDx027
240		2.3L Petrol	Man	02-83	03-86	VOL62100	394						RDx027
240	B230E	2.3L Petrol	Auto	01-85	12-85	VOL62100	394						
240	B230ESR	2.3L Petrol	Auto	01-85	12-85	VOL62100	394						
240	B230F	2.3L Petrol	Man	01-91	12-91	VOL62100	394						
240	B230F	2.3L Petrol	Man	03-86	12-88	VOL62100	394						
240	B23E	2.3L Petrol	Auto	01-85	03-86	VOL62100	394						RDx027
240	B23E	2.3L Petrol	Man	02-83	03-86	VOL62100	394						RDx027
242		2.1L Petrol	Auto	01-75	12-76	VOL62100	394						
242		2.3L Petrol	Auto	03-79	12-81	VOL62100	394						RDx308
242		2.3L Petrol	Man	03-79	12-81	VOL62100	394						RDx308
244		2.1L Petrol	Auto	10-75	12-80	VOL62100	394						RDx308
244		2.1L Petrol	Man	01-79	01-82	VOL62100	394						RDx308
244		2.3L Petrol	Auto	01-79	12-82	VOL62100	394						RDx308
244		2.3L Petrol	Man	01-79	12-82	VOL62100	394						RDx308
245		2.1L Petrol	Auto	01-75	12-82	VOL62100	394						RDx308
245		2.3L Petrol	Auto	01-81	12-82	VOL62100	394						RDx308
245		2.3L Petrol	Man	01-81	12-82	VOL62100	394						RDx308
260		2.8L Petrol	Auto	01-83	12-85	VOL62100	394						
260		2.8L Petrol	Man	01-83	12-85	VOL62100	394						

MODEL	SERIES	ENGINE	TRANS	YEAR FROM	YEAR TO	RADIATOR OPTION 1	PAGE	RADIATOR OPTION 2	PAGE	CONDENSER OPTION 1	CONDENSER OPTION 2	RECEIVER DRIER OPTION 1	RECEIVER DRIER OPTION 2
264		2.8L Petrol	Auto	02-81	02-84	VOL62100	394						
264		2.8L Petrol	Man	02-81	03-83	VOL62100	394						
265		2.7L Petrol	Auto	06-76	02-81	VOL62100	394						
265		2.8L Petrol	Auto	02-81	12-85	VOL62100	394						
265		2.8L Petrol	Man	02-81	12-82	VOL62100	394						
360		2.0L Petrol	Man	01-84	11-88	VOL62100	394						
440		2.0L Petrol	Auto	11-93	09-96	VOL62100	394						
440		2.0L Petrol	Man	11-93	09-96	VOL09031	394						
740		2.3L Petrol	Auto	06-85	02-90	VOL62100	394					RD305	
760		2.3L Turbo Petrol	Auto	01-84	01-86	VOL62100	394						
760		2.3L Turbo Petrol	Man	01-84	01-86	VOL62100	394					RD305	
760		2.8L Petrol	Auto	01-84	12-90	VOL62100	394					RD305	
760	B230ET	2.3L Turbo Petrol	Auto	01-84	06-88	VOL62100	394						
760	B230ET	2.3L Turbo Petrol	Man	01-84	06-88	VOL62100	394					RD305	
850		2.3L Turbo Petrol	Auto	10-93	03-98	VOL06741	395	VOL26761	395			RD307	
850		2.3L Turbo Petrol	Man	10-93	03-98	VOL06741	395	VOL26761	395			RD307	
850		2.4L Petrol	Auto	10-95	03-98	VOL06741	395	VOL26761	395			RD307	
850		2.4L Turbo Petrol	Man	09-96	03-98	VOL06741	395	VOL26761	395				
850		2.4L Petrol	Man	10-94	03-98	VOL06741	395	VOL26761	395				
850		2.4L Petrol	Man	10-94	09-97	VOL06741	395	VOL26761	395				
850	GL	2.4L Petrol	Auto	10-92	09-96	VOL06741	395	VOL26761	395	CNX640		RD307	
850	GL	2.4L Petrol	Man	10-93	09-96	VOL06741	395	VOL26761	395				
850	SE	2.4L Petrol	Man	10-94	03-97	VOL06741	395	VOL26761	395				
960		2.8L Petrol	Auto	11-90	12-91	VOL20791	395					RD308	
960		2.9L Petrol	Auto	12-91	03-98	VOL20791	395					RD308	
262C		2.7L Petrol	Auto	01-80	12-80	VOL62100	394						
262C		2.7L Petrol	Man	01-80	12-80	VOL62100	394						
740 TURBO		2.3L Turbo Petrol	Auto	02-90	11-90	VOL62100	394					RD305	

MODEL	SERIES	ENGINE	TRANS	YEAR FROM	YEAR TO	RADIATOR OPTION 1	PAGE	RADIATOR OPTION 2	PAGE	CONDENSER OPTION 1	CONDENSER OPTION 2	RECEIVER DRIER OPTION 1	RECEIVER DRIER OPTION 2
VOLVO (continued)													
740 TURBO		2.3L Turbo Petrol	Man	02-90	11-90	VOL62100	394						
740 TURBO	B230FT	2.3L Turbo Petrol	Auto	03-86	11-90	VOL62100	394					RDX305	
740 TURBO	B230FT	2.3L Turbo Petrol	Man	03-86	11-90	VOL62100	394					RDX305	
C30	LE-S	2.4L Petrol	Auto	10-08		VOL29601	395						
C30	LE-S	2.4L Petrol	Man	10-08		VOL29601	395						
C30	M SERIES	2.0L Turbo Diesel	Auto	09-09		VOL29601	395						
C30	M SERIES	2.0L Turbo Diesel	Man	01-10		VOL29601	395						
C70		2.3L Turbo Petrol	Auto	04-01	02-04	VOL06741	395	VOL26761	395				
C70		2.3L Turbo Petrol	Man	03-98	02-03	VOL06741	395	VOL26761	395				
C70		2.4L Petrol	Auto	04-06	10-08	VOL06741	395	VOL26761	395				
C70		2.4L Turbo Petrol	Auto	07-99	01-02	VOL06741	395	VOL26761	395				
C70		2.4L Petrol	Man	01-06	12-06	VOL06741	395	VOL26761	395				
C70		2.4L Turbo Petrol	Man	07-99	04-02	VOL06741	395	VOL26761	395				
C70		2.5L Turbo Petrol	Auto	04-06	10-08	VOL06741	395	VOL26761	395				
C70		2.5L Turbo Petrol	Man	04-06	10-08	VOL06741	395	VOL26761	395				
C70	LE	2.4L Petrol	Auto	10-08		VOL06741	395	VOL26761	395				
C70	LE	2.4L Petrol	Man	01-06		VOL06741	395	VOL26761	395				
C70	T5	2.3L Turbo Petrol	Auto	03-98	12-02	VOL06741	395	VOL26761	395				
C70	T5	2.3L Turbo Petrol	Man	08-99	01-02	VOL06741	395	VOL26761	395				
C70	T5	2.5L Turbo Petrol	Auto	10-08		VOL06741	395	VOL26761	395				
C70	T5	2.5L Turbo Petrol	Man	01-06	12-06	VOL06741	395	VOL26761	395				
FH12		12.0L Turbo Diesel	Man	08-93	08-98	VOL26551	396						
FL6		5.5L Turbo Diesel	Man	01-97	01-02	VOL58101	396	VOL58111	396				
FL6		5.5L Diesel	Man	01-98	01-99	VOL58101	396	VOL58111	396				
FL6		5.5L Turbo Diesel	Man	01-97	12-97	VOL58101	396	VOL58111	396				
FM9		9.4L Turbo Diesel	Man	01-03	01-06	VOL75001	396	VOL74791	396	CNX654			
S40		1.8L Petrol	Auto	07-99	08-00	VOL74171	397			CNX649		RDX608	
S40		1.8L Petrol	Man	07-99	08-00	VOL74131	397			CNX649		RDX608	

MODEL	SERIES	ENGINE	TRANS	YEAR FROM	YEAR TO	RADIATOR OPTION 1	PAGE	RADIATOR OPTION 2	PAGE	CONDENSER OPTION 1	CONDENSER OPTION 2	RECEIVER DRIER OPTION 1	RECEIVER DRIER OPTION 2
S40		1.9L Turbo Petrol	Auto	03-98	08-00	VOL74171	397		397	CNX649		RDX608	
S40		1.9L Turbo Petrol	Man	03-98	08-00	VOL74171	397		397	CNX649		RDX608	
S40		2.0L Turbo Petrol	Auto	01-98	12-00	VOL74171	397		397				
S40		2.0L Petrol	Auto	03-97	01-00	VOL74171	397		397	CNX649		RDX608	
S40		2.0L Turbo Petrol	Man	01-98	12-00	VOL74131	397		397				
S40		2.0L Petrol	Man	08-00	04-04	VOL74131	397		397	CNX649		RDX608	
S40		2.0L Turbo Diesel	Man	09-09		VOL29601	395		395				
S40		2.4L Petrol	Auto	02-04	10-08	VOL29601	395		395	CNX649		RDX608	
S40		2.4L Petrol	Man	02-04	10-08	VOL29601	395		395	CNX649		RDX608	
S40		2.5L Turbo Petrol	Auto	01-06	10-08	VOL29601	395		395	CNX649		RDX608	
S40		2.5L Turbo Petrol	Man	01-06	10-08	VOL29601	395		395	CNX649		RDX608	
S40	LE-S	2.4L Petrol	Auto	10-08		VOL29601	395		395	CNX649		RDX608	
S40	LE-S	2.4L Petrol	Man	10-08		VOL29601	395		395	CNX649		RDX608	
S40	PHASE 2	2.0L Turbo Petrol	Auto	08-00	01-04	VOL74171	397		397				
S40	PHASE 2	2.0L Petrol	Auto	08-00	12-04	VOL74171	397		397				
S40	PHASE 2	2.0L Turbo Petrol	Man	08-00	01-04	VOL74171	397		397				
S40	PHASE 2	2.0L Petrol	Man	08-00	12-04	VOL74131	397		397				
S40	T5	2.5L Turbo Petrol	Auto	02-04	02-06	VOL74231	397		397	CNX649		RDX608	
S40	T5	2.5L Turbo Petrol	Man	02-04	02-06	VOL74231	397		397	CNX649		RDX608	
S40	T5	2.5L Turbo Petrol	Man	09-09		VOL29601	395		395				
S60		2.4L Turbo Petrol	Auto	01-00	02-04	VOL74231	397		397			RDX6154	
S60		2.4L Petrol	Auto	12-00	10-08	VOL74231	397		397			RDX6154	
S60		2.4L Turbo Petrol	Man	01-00	02-04	VOL74231	397		397				
S60		2.4L Petrol	Man	12-00	10-06	VOL74231	397		397			RDX6154	
S60	R	2.5L Turbo Petrol	Auto	02-03	10-08	VOL74231	397		397				
S60	R	2.5L Turbo Petrol	Man	11-03	01-06	VOL74231	397		397				
S60	S60	2.4L Turbo Petrol	Auto	12-00	07-03	VOL74231	397		397			RDX6154	
S60	S60	2.4L Turbo Petrol	Man	12-00	07-03	VOL74231	397		397			RDX6154	
S60	T5	2.3L Turbo Petrol	Auto	12-00	07-03	VOL74231	397		397			RDX6154	

Vehicle Application Guide

Vehicle Application Guide

MODEL	SERIES	ENGINE	TRANS	YEAR FROM	YEAR TO	RADIATOR OPTION 1	PAGE	RADIATOR OPTION 2	PAGE	CONDENSER OPTION 1	CONDENSER OPTION 2	RECEIVER DRIER OPTION 1	RECEIVER DRIER OPTION 2
VOLVO (continued)													
S60	T5	2.3L Turbo Petrol	Man	12-00	07-03	VOL74231	397						RDX6154
S70		2.3L Turbo Petrol	Auto	03-97	10-98	VOL06741	395	VOL26761	395				
S70		2.3L Turbo Petrol	Man	03-97	10-98	VOL06741	395	VOL26761	395				
S70		2.4L Petrol	Auto	03-97	01-01	VOL06741	395	VOL26761	395				RDX6154
S70		2.4L Turbo Petrol	Auto	03-97	01-01	VOL06741	395	VOL26761	395				RDX6154
S70		2.4L Petrol	Man	03-97	01-01	VOL06741	395	VOL26761	395				RDX6154
S70		2.4L Turbo Petrol	Man	03-97	01-01	VOL06741	395	VOL26761	395				RDX6154
S80	T5	2.5L Turbo Petrol	Auto	10-04	03-07	VOL74231	397			CNX662			
S80	T6	2.8L Petrol	Auto	05-98	01-06	VOL74231	397						
S90		2.9L Petrol	Auto	03-97	10-98	VOL20791	395						
V40		1.8L Petrol	Man	07-99	08-00	VOL74171	397			CNX649			RDX608
V40		1.8L Petrol	Man	08-00	04-02	VOL74171	397			CNX649			RDX608
V40		1.9L Turbo Petrol	Auto	01-98	02-05	VOL74171	397			CNX649			RDX608
V40		1.9L Turbo Petrol	Man	03-98	12-04	VOL74171	397			CNX649			RDX608
V40		2.0L Petrol	Auto	03-97	08-00	VOL74171	397			CNX649			RDX608
V40		2.0L Turbo Petrol	Auto	03-98	08-00	VOL74171	397			CNX649			RDX606
V40		2.0L Turbo Petrol	Man	01-99	04-04	VOL74171	397			CNX649			RDX606
V40		2.0L Petrol	Man	03-97	04-05	VOL74171	397			CNX649			RDX608
V50		2.0L Turbo Diesel	Man	09-09		VOL29601	395						
V50		2.4L Petrol	Man	02-04	10-08	VOL29601	395						
V50	LE-S	2.4L Petrol	Auto	10-08		VOL29601	395						
V50	LE-S	2.4L Petrol	Man	10-08		VOL29601	395						
V50	T5	2.5L Turbo Petrol	Auto	01-06	10-08	VOL74231	397						
V50	T5	2.5L Turbo Petrol	Auto	02-04	01-06	VOL29601	395						
V50	T5	2.5L Turbo Petrol	Man	09-09		VOL29601	395						
V70		2.3L Turbo Petrol	Auto	10-97	09-00	VOL06741	395	VOL26761	395				
V70		2.3L Turbo Petrol	Man	10-97	12-98	VOL06741	395	VOL26761	395	CNX662			

MODEL	SERIES	ENGINE	TRANS	YEAR FROM	YEAR TO	RADIATOR OPTION 1	PAGE	RADIATOR OPTION 2	PAGE	CONDENSER OPTION 1	CONDENSER OPTION 2	RECEIVER DRIER OPTION 1	RECEIVER DRIER OPTION 2
V70		2.4L Turbo Petrol	Auto	03-97	02-01	VOL06741	395	VOL26761	395	CNX662		RDX6154	
V70		2.4L Petrol	Auto	09-00	04-05	VOL06741	395	VOL26761	395	CNX662			
V70		2.4L Petrol	Man	01-05	01-08	VOL06741	395	VOL26761	395	CNX662			
V70		2.4L Turbo Petrol	Man	02-00	04-04	VOL06741	395	VOL26761	395	CNX662		RDX6154	
V70		2.5L Turbo Petrol	Auto	03-98	09-00	VOL06741	395	VOL26761	395	CNX662			
V70		2.5L Turbo Petrol	Man	03-97	09-00	VOL06741	395	VOL26761	395	CNX662			
V70	BW	3.0L Turbo Petrol	Auto	09-10		VOL06741	395	VOL26761	395				
V70	T5	2.3L Turbo Petrol	Auto	02-00	04-04	VOL06741	395	VOL26761	395	CNX662			
V70	T5	2.3L Turbo Petrol	Man	03-97	10-98	VOL06741	395	VOL26761	395				
V70	T6	3.0L Turbo Petrol	Auto	03-08		VOL06741	395	VOL26761	395	CNX761			
V70	XC	2.5L Turbo Petrol	Auto	11-03	01-06	VOL06741	395	VOL26761	395				
V90	SE	2.9L Petrol	Auto	03-97	02-99	VOL20791	395						
XC60	D5	2.4L Turbo Diesel	Auto	02-09		VOL74201	395						
XC60	T6	3.0L Turbo Petrol	Auto	02-09		VOL74201	395						
XC70		2.4L Turbo Petrol	Auto	09-00	02-03	VOL74231	397	VOL74201	395				
XC70		2.4L Turbo Petrol	Man	09-00	02-03	VOL74231	397	VOL74201	395				
XC70	Cross Country	2.5L Turbo Petrol	Auto	02-03	10-04	VOL74201	395			CNX662			
XC70	Cross Country	2.5L Turbo Petrol	Man	02-03	10-04	VOL74201	395			CNX662			
XC70	D5	2.4L Turbo Diesel	Auto	01-07	09-09	VOL74201	395						
XC70	LE	2.5L Turbo Petrol	Auto	03-04	06-05	VOL74201	395						
XC70	LE	2.5L Turbo Petrol	Man	10-04	08-06	VOL74201	395						
XC70	SE	2.5L Turbo Petrol	Auto	07-05	01-08	VOL74201	395						
XC90		2.4L Turbo Diesel	Auto	10-06	10-08	VOL74201	395						
XC90		2.5L Turbo Petrol	Auto	07-03	03-08	VOL74231	397			CNX662			
XC90		2.9L Turbo Petrol	Auto	07-03	10-06	VOL74231	397						
XC90	D5	2.4L Turbo Diesel	Auto	10-08		VOL74201	395						

It's DENSO RELAX

DENSO

- **Maximum Cool**

- Superior fin wave construction provides a higher heat transfer coefficient.

- **Ultimate Durability**

- Strict OE manufacturing standards ensure
- DENSO radiators can withstand the most demanding Australian conditions.



- **Precision Built**

- No need for adjustment, just drop it in for an easy fit - first time.

**Reliable performance.
Superior efficiency.
So you can keep your cool.**

DENSO

THERMAL SYSTEMS

It's DENSO, relax. Aussie conditions are rough, we need radiators that won't get all hot and steamy under the collar, chicken out and leave us stranded. DENSO radiators, just like Crocodile Dundee or 'Dirty' Harry Callahan, are tough, built to last and designed to keep their cool under pressure. So you've gotta ask yourself, can your radiator handle the heat? Make the switch and 'RELAX' with DENSO.

Check out the full line of quality DENSO products at www.denso.com.au

a/c components | alternators | bus a/c | caravan a/c | data capture | fuel pumps | electronic systems | engine cooling systems | filters | fuel pump modules | ignition system | instrument clusters | movincool | oil coolers | radiators | robotics | satellite nav. | sensors | spark plugs | starter motors | wiper systems

It's DENSO RELAX

DENSO

More resistant.
Higher output.
No worries.

Valve Shaft and Swash Plate

Designed with a lightweight aluminum alloy for added strength.

Thrust Bearing

Structured to withstand tension and stress for maximum durability.

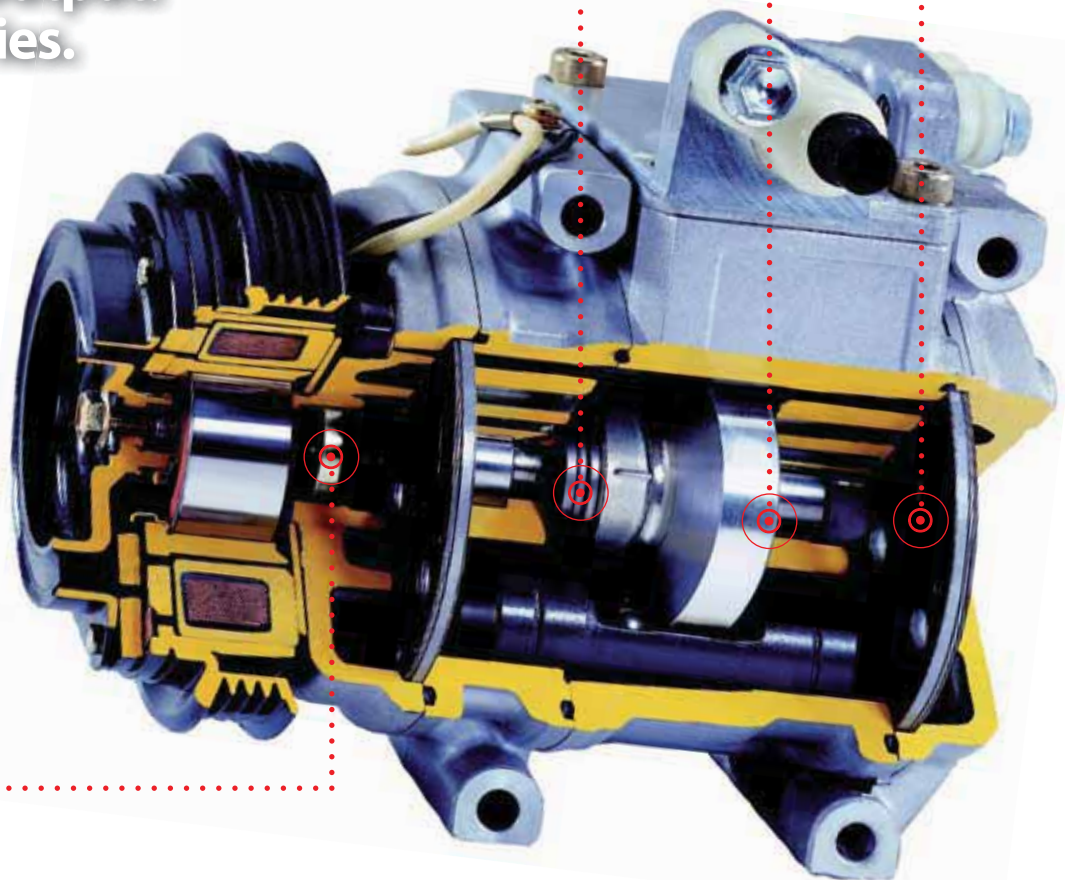

Snap Rings

Improve performance under extreme heat.

DENSO

THERMAL SYSTEMS

It's DENSO, relax. Why are we the world's largest supplier of A/C components? Because DENSO compressors and components are built to meet the most stringent requirements of vehicle makers throughout the world. High output, reduced noise and extended reliability in harsh high-vibration applications - you could say we like it rough. Which is exactly why you can 'RELAX' knowing your vehicle is working as hard as you do.

Check out the full line of quality DENSO products at www.denso.com.au

a/c components | alternators | bus a/c | caravan a/c | data capture | fuel pumps | electronic systems | engine cooling systems | filters | fuel pump modules | ignition system | instrument clusters | movincool | oil coolers | radiators | robotics | satellite nav. | sensors | spark plugs | starter motors | wiper systems

Cross Flow

O'Ring Type, Seal Radiator

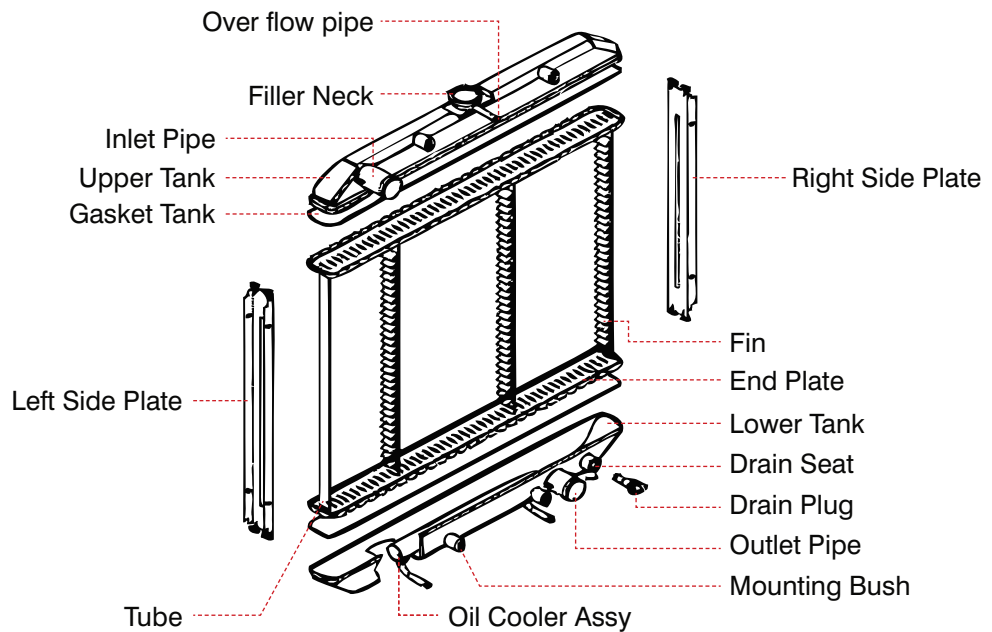

Down Flow

Solder Type, Core to header Joint Radiator

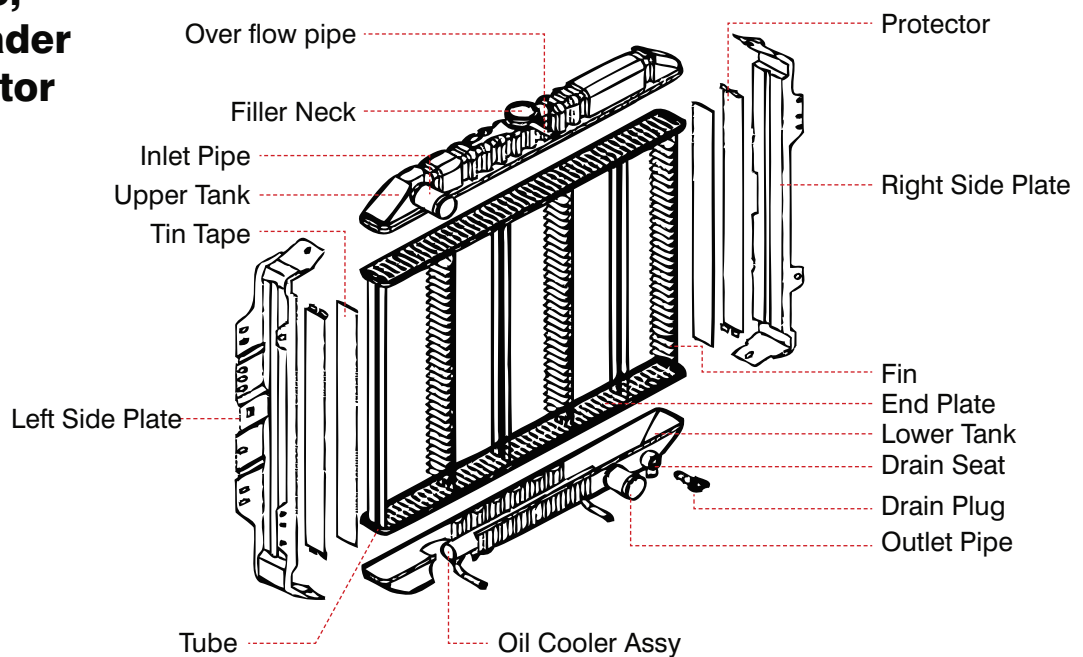

ALF66111

To suit Alfa Romeo 147 190J
4 cyl 1.9L Turbo Diesel 2005 - 2009



ALUMINIUM / PLASTIC
MANUAL

Core Height	580mm	Core Width	410mm
Core Thickness	27mm	Inlet / Outlet	35 / 35
Oil Cooler	N/A		
Condenser		Receiver Drier	

Notes:

ALF66081

To suit Alfa Romeo 147
4 cyl 2.0L Twin Spark 1/2001 - 7/2009



ALUMINIUM / PLASTIC
MANUAL

Core Height	578mm	Core Width	414mm
Core Thickness	27mm	Inlet / Outlet	35 / 35
Oil Cooler	N/A		
Condenser	CDX772	Receiver Drier	RDX281

Notes: Clip on Fittings

ALF66001

To suit Alfa Romeo 156 GTV
V6 3.2L 8/2002 - 1/2004



ALUMINIUM / PLASTIC
MANUAL

Core Height	554mm	Core Width	412mm
Core Thickness	24mm 1 Row	Inlet / Outlet	36 / 36
Oil Cooler	N/A		
Condenser	CNX779	Receiver Drier	RDX281

Notes:

ALF18121

To suit Alfa Romeo 156, JTS
4 cyl 2.0L & V6 2.5L 1999 - 2007



ALUMINIUM / PLASTIC
MANUAL

Core Height	580mm	Core Width	405mm
Core Thickness	24mm 1 Row	Inlet / Outlet	35 / 35
Oil Cooler	N/A		
Condenser	CNX779 / CNX778	Receiver Drier	RDX281

Notes: Condenser CNX779 is subcooled

ALF66061

To suit Alfa Romeo 166
V6 3.0L 1999 - 9/2007



ALUMINIUM / PLASTIC
MANUAL

Core Height	658mm	Core Width	416mm
Core Thickness	35mm	Inlet / Outlet	28 / 32
Oil Cooler	N/A		
Condenser		Receiver Drier	RDX281

Notes: Clip on Fittings

AUD11581

To suit Audi 80 B4
4 cyl 2.0L & 5 cyl 2.3L 4/1989 - 10/1993



ALUMINIUM / PLASTIC
AUTOMATIC

Core Height	480mm	Core Width	375mm
Core Thickness	42mm 1 Row	Inlet / Outlet	32 / 32
Oil Cooler	375mm	Receiver Drier	RDX375 (Metric)
Condenser	CNX560 / CNX873	Receiver Drier	RDX377 (Imperial)

Notes: CNX560 - R13a, CNX873 - R12

AUD15161

To suit Audi 80 B4 Cabriolet
V6 2.6L & 2.8L 7/1992 - 12/1999



ALUMINIUM / PLASTIC
AUTOMATIC

Core Height	600mm	Core Width	405mm
Core Thickness	34mm 1 Row	Inlet / Outlet	32 / 32
Oil Cooler	220mm	Receiver Drier	RDX375 (metric)
Condenser	CNX560 / CNX873	Receiver Drier	RDX377 (imperial)

Notes: CNX560 (R134a) / CNX873 (R12)

AUD14601

To suit Audi 80 B4
V6 2.6L 10/1993 - 8/1995



ALUMINIUM / PLASTIC
MANUAL

Core Height	600mm	Core Width	405mm
Core Thickness	34mm 1 Row	Inlet / Outlet	32 / 32
Oil Cooler	N/A	Receiver Drier	RDX375 (metric)
Condenser	CNX560 / CNX873	Receiver Drier	RDX377 (imperial)

Notes: CNX560 (R134a) / CNX873 (R12)

VW26701

To suit Audi A3 TFSI
4 cyl 1.4L Turbo Petrol 11/2008 >



ALUMINIUM / PLASTIC
AUTOMATIC & MANUAL

Core Height	650mm	Core Width	410mm
Core Thickness	34mm 2 Row	Inlet / Outlet	32 / 32
Oil Cooler	N/A		
Condenser		Receiver Drier	

Notes:

VW74031

To suit Audi A3
4 cyl 1.8 & 2.0L Turbo Petrol 1/2007 >



ALUMINIUM / PLASTIC
AUTOMATIC & MANUAL

Core Height	650mm	Core Width	451mm
Core Thickness	34mm 2 Row	Inlet / Outlet	32 / 32
Oil Cooler	N/A		
Condenser	CNX870	Receiver Drier	RDX370

Notes:

VW74041

To suit Audi A3 TFSI Quattro
4 cyl 2.0L Turbo Petrol 2/2005 >



ALUMINIUM / PLASTIC
MANUAL

Core Height	650mm	Core Width	455mm
Core Thickness	32mm 1 Row	Inlet / Outlet	32 / 32
Oil Cooler	N/A		
Condenser	CNX870	Receiver Drier	RDX370

Notes:

VW65121

To suit Audi A3
4 cyl 1.9 & 2.0L Turbo Diesel 6/2004 >



ALUMINIUM / PLASTIC
AUTOMATIC & MANUAL

Core Height	650mm	Core Width	451mm
Core Thickness	34mm 2 Row	Inlet / Outlet	32 / 32
Oil Cooler	N/A		
Condenser	CNX870	Receiver Drier	RDX370

Notes:

VW81091

To suit Audi A3
4 cyl 1.6 & 2.0L Petrol 6/2004 >



ALUMINIUM / PLASTIC
AUTOMATIC & MANUAL

Core Height	650mm	Core Width	406mm
Core Thickness	26mm 1 Row	Inlet / Outlet	32 / 32
Oil Cooler	N/A		
Condenser	CNX870	Receiver Drier	RDX370

Notes:

VW13781

To suit Audi A3 A4
4 cyl 1.6 & 1.8L Petrol inc Turbo 5/1997 - 2/2006



ALUMINIUM / PLASTIC
MANUAL

Core Height	650mm	Core Width	415mm
Core Thickness	24mm 2 Row	Inlet / Outlet	32 / 32
Oil Cooler	N/A		
Condenser	CNX860	Receiver Drier	RDX378

Notes:

AUD16621

To suit Audi A4 B5 Avant
4 cyl 1.8L V6 2.4, 2.6 & 2.8L 8/1995 - 7/2001



ALUMINIUM / PLASTIC
AUTOMATIC

Core Height	630mm	Core Width	412mm
Core Thickness	32mm 1 Row	Inlet / Outlet	42 / 42
Oil Cooler	300mm		
Condenser	CNX871	Receiver Drier	RDX375

Notes: Clip on Fittings. Sender Port on P/S

AUD15331

To suit Audi A4 B5 Avant
V6 2.4 & 2.6L 8/1995 - 4/2000



ALUMINIUM / PLASTIC
MANUAL

Core Height	630mm	Core Width	390mm
Core Thickness	36mm 2 Row	Inlet / Outlet	32 / 32
Oil Cooler	N/A		
Condenser	CNX561	Receiver Drier	RDX375

Notes:

VW20591

To suit Audi A4 B5 B6 Avant
4 cyl 1.8L & V6 2.6L inc Turbo 8/1995 - 5/2004



ALUMINIUM / PLASTIC
MANUAL

Core Height	630mm	Core Width	397mm
Core Thickness	36mm 1 Row	Inlet / Outlet	32 / 32
Oil Cooler	N/A		
Condenser	CNX864	Receiver Drier	RDX375

Notes: Clip on Fittings

AUD20601

To suit Audi A4 B5 B6 Avant
4 cyl 1.8L V6, 2.4, 2.6 & 2.8L 10/1996 - 12/2005



ALUMINIUM / PLASTIC
AUTOMATIC

Core Height	630mm	Core Width	400mm
Core Thickness	32mm 1 Row	Inlet / Outlet	32 / 32
Oil Cooler	300mm		
Condenser	CNX561 / CNX864	Receiver Drier	RDX375

Notes: Clip on Fittings

AUD16621

To suit Audi A4 B5 B6 Avant
4 cyl 1.8L inc Turbo 1/1996 - 5/2004



ALUMINIUM / PLASTIC
AUTOMATIC

Core Height	630mm	Core Width	412mm
Core Thickness	32mm 1 Row	Inlet / Outlet	42 / 42
Oil Cooler	300mm		
Condenser	CNX864	Receiver Drier	RDX375

Notes: Clip on Fittings. Sensor Port on P/S

AUD45631

To suit Audi A4 B6 B7 B8 Avant
4 cyl 2.0L Turbo Diesel 2/2005 >



ALUMINIUM / PLASTIC
AUTOMATIC

Core Height	720mm	Core Width	477mm
Core Thickness	26mm 1 Row	Inlet / Outlet	32 / 32
Oil Cooler	300mm		
Condenser		Receiver Drier	

Notes: Clip on Fittings

AUD17231

To suit Audi A4 B6 B7 B8 Avant
4 cyl 1.8 & 2.0L 2/2005 - 5/2009



ALUMINIUM / PLASTIC
AUTOMATIC

Core Height	635mm	Core Width	414mm
Core Thickness	34mm 1 Row	Inlet / Outlet	32 / 32
Oil Cooler	300mm		
Condenser	CNX562	Receiver Drier	RDX375

Notes: Clip on Fittings

AUD45631

To suit Audi A4 B6 B8 Avant
4 cyl 1.8 & 2.0L Turbo Petrol 1/2003 >



ALUMINIUM / PLASTIC
AUTOMATIC

Core Height	720mm	Core Width	477mm
Core Thickness	26mm 1 Row	Inlet / Outlet	32 / 32
Oil Cooler	300mm		
Condenser		Receiver Drier	

Notes: Clip on Fittings

AUD15341

To suit Audi A4 B6 B7
V6 3.0 & 3.1L 1/2002 - 1/2010



ALUMINIUM / PLASTIC
AUTOMATIC

Core Height	630mm	Core Width	445mm
Core Thickness	31mm	Inlet / Outlet	32 / 32
Oil Cooler	300mm		
Condenser		Receiver Drier	

Notes: Clip on Fittings

AUD15341

To suit Audi A4 B6
V6 3.0L Turbo Diesel 10/2001 - 2/2006



ALUMINIUM / PLASTIC
AUTOMATIC

Core Height	630mm	Core Width	445mm
Core Thickness	31mm	Inlet / Outlet	32 / 32
Oil Cooler	299mm		
Condenser		Receiver Drier	

Notes: Clip on Fittings

AUD66261

To suit Audi A4 B6 B7 Avant
4 cyl 1.8 & 2.0L inc Turbo Petrol
7/2001 - 5/2009



ALUMINIUM / PLASTIC
MANUAL

Core Height	630mm	Core Width	415mm
Core Thickness	24mm 1 Row	Inlet / Outlet	
Oil Cooler	N/A		
Condenser	CNX562	Receiver Drier	RDX375

Notes: Clip on Fittings

AUD45581

To suit Audi A4 B7 Avant B8 Quattro
4 cyl 1.8, 2.0 & V6 3.2L Turbo Petrol
1/2006 >



ALUMINIUM / PLASTIC
MANUAL

Core Height	720mm	Core Width	477mm
Core Thickness	26mm 1 Row	Inlet / Outlet	32 / 32
Oil Cooler	N/A		
Condenser		Receiver Drier	

Notes: Clip on Fittings

AUD53491

To suit Audi A4 B7 B8 Quattro
4 cyl 1.8 & 2.0L Turbo Petrol 1/2006 >



ALUMINIUM / PLASTIC
MANUAL

Core Height	720mm	Core Width	477mm
Core Thickness	26mm 1 Row	Inlet / Outlet	32 / 32
Oil Cooler	N/A		
Condenser		Receiver Drier	

Notes:

AUD17231

To suit Audi A4 B7 Avant
1.8 & 2.0L Turbo Petrol 2/2005 - 12/2009



ALUMINIUM / PLASTIC
AUTOMATIC

Core Height	635mm	Core Width	414mm
Core Thickness	34mm 1 Row	Inlet / Outlet	32 / 32
Oil Cooler	300mm		
Condenser	CNX562	Receiver Drier	RDX375

Notes: Clip on Fittings

AUD66261

To suit Audi A4 B7 Quattro
4 cyl 1.8 & 2.0L Turbo Petrol 2/2005 - 5/2009



ALUMINIUM / PLASTIC
MANUAL

Core Height	630mm	Core Width	415mm
Core Thickness	24mm 1 Row	Inlet / Outlet	
Oil Cooler	N/A		
Condenser	CNX562	Receiver Drier	RDX375

Notes: Clip on Fittings

AUD17231

To suit Audi A4 B7
4 cyl 2.0L Turbo Diesel 10/2005 - 8/2008



ALUMINIUM / PLASTIC
AUTOMATIC

Core Height	635mm	Core Width	414mm
Core Thickness	34mm 1 Row	Inlet / Outlet	32 / 32
Oil Cooler	300mm		
Condenser	CNX562	Receiver Drier	RDX375

Notes: Clip on Fittings

AUD53491

To suit Audi A4 B8
4 cyl 2.0L Turbo Diesel 1/2010 >



Core Height	720mm	Core Width	477mm
Core Thickness	26mm 1 Row	Inlet / Outlet	32 / 32
Oil Cooler	N/A		
Condenser		Receiver Drier	

Notes:

AUD45581

To suit Audi A4 B8 Quattro
4 cyl 2.0L & V6 3.0L Turbo Petrol & Diesel
8/2009 >



Core Height	720mm	Core Width	477mm
Core Thickness	26mm 1 Row	Inlet / Outlet	32 / 32
Oil Cooler	N/A		
Condenser		Receiver Drier	

Notes: Clip on Fittings

AUD53491

To suit Audi A5 Quattro
V6 3.0L Turbo Diesel 8/2009 >



Core Height	720mm	Core Width	477mm
Core Thickness	26mm 1 Row	Inlet / Outlet	32 / 32
Oil Cooler	N/A		
Condenser		Receiver Drier	RDX372

Notes:

AUD53491

To suit Audi A5 Quattro
4 cyl & V6 3.2L inc Turbo 5/2009 >



Core Height	720mm	Core Width	477mm
Core Thickness	26mm 1 Row	Inlet / Outlet	32 / 32
Oil Cooler	N/A		
Condenser		Receiver Drier	RDX372

Notes:

AUD45631

To suit Audi A5 Quattro
V6 3.0L Turbo Diesel 12/2008 >



Core Height	720mm	Core Width	477mm
Core Thickness	26mm 1 Row	Inlet / Outlet	32 / 32
Oil Cooler	300mm		
Condenser		Receiver Drier	RDX372

Notes: Clip on Fittings

AUD45631

To suit Audi A5 Quattro
4 cyl 2.0L & V6 3.2L Petrol 9/2007 >



Core Height	720mm	Core Width	477mm
Core Thickness	26mm 1 Row	Inlet / Outlet	32 / 32
Oil Cooler	300mm		
Condenser		Receiver Drier	RDX372

Notes: Clip on Fittings

AUD15341

To suit Audi A6 4B AUK Avant Quattro
V6 3.0 & 3.1L 2/2002 - 2/2009



ALUMINIUM / PLASTIC
AUTOMATIC

Core Height	630mm	Core Width	445mm
Core Thickness	31mm	Inlet / Outlet	32 / 32
Oil Cooler	300mm		
Condenser		Receiver Drier	

Notes: Clip on Fittings

AUD20601

To suit Audi A6 4B C5 C7
4 cyl 2.0L V6 2.4 2.6 & 2.8L inc Turbo
1/1997 - 2/2009



ALUMINIUM / PLASTIC
AUTOMATIC

Core Height	630mm	Core Width	400mm
Core Thickness	32mm 1 Row	Inlet / Outlet	32 / 32
Oil Cooler	300mm		
Condenser		Receiver Drier	RDX375

Notes: Clip on Fittings

AUD19091

To suit Audi A6 Quattro
V8 4.2L 10/2004 - 2/2009



ALL ALUMINIUM
AUTOMATIC & MANUAL

Core Height	725mm	Core Width	478mm
Core Thickness	40mm	Inlet / Outlet	
Oil Cooler	N/A		
Condenser		Receiver Drier	

Notes:

AUD15261

To suit Audi A6 Quattro
V8 4.2L 10/2004 - 2/2009



ALUMINIUM / PLASTIC
AUTOMATIC

Core Height	630mm	Core Width	415mm
Core Thickness	34mm	Inlet / Outlet	32 / 32
Oil Cooler	305mm		
Condenser		Receiver Drier	

Notes:

AUD15331

To suit Audi A8
V6 2.8L 5/1995 - 1/1997



ALUMINIUM / PLASTIC
MANUAL

Core Height	630mm	Core Width	397mm
Core Thickness	36mm 2 Row	Inlet / Outlet	32 / 32
Oil Cooler	N/A		
Condenser		Receiver Drier	

Notes:

AUD19091

To suit Audi A8
V8 3.7 & 4.2L 8/2003 >



ALL ALUMINIUM
AUTOMATIC & MANUAL

Core Height	725mm	Core Width	478mm
Core Thickness	40mm	Inlet / Outlet	
Oil Cooler	N/A		
Condenser		Receiver Drier	

Notes:

AUD15341

To suit Audi B6 B7 Cabriolet
V6 3.0L & 3.1L 12/2002 - 6/2006



ALUMINIUM / PLASTIC
AUTOMATIC

Core Height	630mm	Core Width	445mm
Core Thickness	31mm	Inlet / Outlet	32 / 32
Oil Cooler	300mm		
Condenser		Receiver Drier	

Notes: Clip on Fittings

AUD19001

To suit Audi Q7
V6 3.0L Petrol Supercharged 9/2010 >



ALUMINIUM / PLASTIC
AUTOMATIC & MANUAL

Core Height	710mm	Core Width	550mm
Core Thickness	40mm 1 Row	Inlet / Outlet	38 / 38
Oil Cooler	N/A		
Condenser	CNX910	Receiver Drier	RDX922

Notes:

AUD19001

To suit Audi Q7 Quattro
V6 3.0L V8 4.1L V12 5.9L Turbo Diesel
8/2006 - 10/2009



ALUMINIUM / PLASTIC
AUTOMATIC & MANUAL

Core Height	710mm	Core Width	550mm
Core Thickness	40mm 1 Row	Inlet / Outlet	38 / 38
Oil Cooler	N/A		
Condenser	CNX910	Receiver Drier	RDX922

Notes:

AUD19001

To suit Audi Q7 Quattro
V6 3.6L & V8 4.2L Petrol 8/2006 >



ALUMINIUM / PLASTIC
AUTOMATIC & MANUAL

Core Height	710mm	Core Width	550mm
Core Thickness	40mm 1 Row	Inlet / Outlet	38 / 38
Oil Cooler	N/A		
Condenser	CNX910	Receiver Drier	RDX922

Notes:

VW13781

To suit Audi S3
1.8L Turbo 11/1999 - 6/2004



ALUMINIUM / PLASTIC
MANUAL

Core Height	650mm	Core Width	415mm
Core Thickness	24mm 2 Row	Inlet / Outlet	32 / 32
Oil Cooler	N/A		
Condenser	CNX860	Receiver Drier	RDX378

Notes:

VW13781

To suit Audi TT Quattro
4 cyl 1.8L Turbo 5/1999 - 10/2006



ALUMINIUM / PLASTIC
MANUAL

Core Height	650mm	Core Width	415mm
Core Thickness	24mm 2 Row	Inlet / Outlet	32 / 32
Oil Cooler	N/A		
Condenser	CNX860	Receiver Drier	RDX378

Notes:

VW74031

To suit Audi TT TFSI Quattro
4 cyl 2.0L Turbo 10/2006 >



Core Height	650mm	Core Width	451mm
Core Thickness	34mm 2 Row	Inlet / Outlet	32 / 32
Oil Cooler	N/A		
Condenser	CNX870	Receiver Drier	RDX370

Notes:

D1CA

To suit BMW 118i 120d, 120i, 125i, 130i,
135i, E82, E87, E88
4 & 6 cyl inc Turbo 9/2004 >



Core Height	600mm	Core Width	460mm
Core Thickness	30mm 1 Row	Inlet / Outlet	38 / 38
Oil Cooler	N/A		
Condenser	CNX697	Receiver Drier	RDX058

Notes:

D1CM

To suit BMW 116i, 118i, 120i, 125i, 130i,
135i E82 E87 E88
4 & 6 cyl inc Turbo 9/2004 >



Core Height	600mm	Core Width	460mm
Core Thickness	30mm 1 Row	Inlet / Outlet	38 / 38
Oil Cooler	N/A		
Condenser		Receiver Drier	

Notes:

BMW54031

To suit BMW 118d, 120d, 123d
E82, E87, E88
4 cyl Turbo Diesel 9/2009 >



Core Height	600mm	Core Width	340mm
Core Thickness	34mm 1 Row	Inlet / Outlet	38 / 38
Oil Cooler	N/A		
Condenser		Receiver Drier	RDX058

Notes:

BMW54061

To suit BMW 116i, 120i, 125i, 130i
E82 E87 E88
4 & 6 cyl 9/2004 >



Core Height	600mm	Core Width	450mm
Core Thickness	32mm 1 Row	Inlet / Outlet	38 / 38
Oil Cooler	N/A		
Condenser		Receiver Drier	

Notes:

BMW54071

To suit BMW 118i, 120i, 125i, 130i,
135i, E82, E87, E88
4 & 6 cyl inc Turbo 9/2004 >



Core Height	600mm	Core Width	455mm
Core Thickness	34mm 1 Row	Inlet / Outlet	38 / 38
Oil Cooler	N/A		
Condenser	CNX697	Receiver Drier	RDX058

Notes: Open Pipe at the bottom of L/H tank.

BMW13251

To suit BMW 316i, 318i, 320i, 323i, 325i, 3289i E36
4 & 6 cyl 5/1991 - 9/2000



ALUMINIUM / PLASTIC
AUTOMATIC

Core Height	550mm	Core Width	430mm
Core Thickness	32mm 1 Row	Inlet / Outlet	40 / 40
Oil Cooler	210mm		
Condenser	CNX620	Receiver Drier	RDX043

Notes:

BMW16241

To suit BMW 316i, 318i, 320i, 323i, 325i, 328i, 330ci E46
4 & 6 cyl inc Turbo 1/1997 - 3/2007



ALUMINIUM / PLASTIC
MANUAL

Core Height	580mm	Core Width	445mm
Core Thickness	29mm 1 Row	Inlet / Outlet	38 / 38
Oil Cooler	N/A		
Condenser	CNX630	Receiver Drier	RDX055

Notes: Clip on Fittings. Closed pipe at lower left tank

BMW13121

To suit BMW 316i, 318i, 320i, 323i, 325i, 328i E36
4 & 6 cyl 5/1991 - 2/2002



ALUMINIUM / PLASTIC
MANUAL

Core Height	440mm	Core Width	435mm
Core Thickness	32mm 1 Row	Inlet / Outlet	40 / 40
Oil Cooler	N/A		
Condenser	CNX620	Receiver Drier	RDX045

Notes:

BMW11571

To suit BMW 316i E36
4 cyl 1.6 & 1.9L 3/1995 - 2/2002



ALUMINIUM / PLASTIC
AUTOMATIC

Core Height	440mm	Core Width	435mm
Core Thickness	34mm 1 Row	Inlet / Outlet	40 / 40
Oil Cooler	210mm		
Condenser	CNX620 / CNX633	Receiver Drier	RDX045

Notes:

BMW16271

To suit BMW 316ti, 318i, 318ti, 320i, 323i, 325i, 328i, 330i E46
4 & 6 cyl 1/1997 - 3/2007



ALUMINIUM / PLASTIC
AUTOMATIC

Core Height	580mm	Core Width	445mm
Core Thickness	34mm 1 Row	Inlet / Outlet	38 / 38
Oil Cooler	N/A		
Condenser	CNX630	Receiver Drier	

Notes: Clip on Fittings

BMW16251

To suit BMW 316ti, 318i, 320i, 320ci, 323i, 325i, 328i, 330i E46
4 & 6 cyl 1/1997 - 3/2007



ALUMINIUM / PLASTIC
AUTOMATIC

Core Height	580mm	Core Width	445mm
Core Thickness	30mm 1 Row	Inlet / Outlet	38 / 38
Oil Cooler	N/A		
Condenser	CNX630	Receiver Drier	RDX055

Notes: Clip on Fittings. Open pipe at bottom right tank

BMW17221

To suit BMW 318i 320i E30
4 & 6 cyl 1/1976 - 2/1992



ALUMINIUM / PLASTIC
MANUAL

Core Height	380mm	Core Width	315mm
Core Thickness	34mm 1 Row	Inlet / Outlet	40 / 40
Oil Cooler	N/A		
Condenser	CNX621	Receiver Drier	RDX047

Notes:

BMW13261

To suit BMW 318i, 325e E30
4 & 6 cyl 1/1980 - 1/1991



ALUMINIUM / PLASTIC
MANUAL

Core Height	350mm	Core Width	450mm
Core Thickness	36mm 2 Row	Inlet / Outlet	36 / 36
Oil Cooler	N/A		
Condenser		Receiver Drier	RDX043

Notes:

BMW13251

To suit BMW 318i, 325e E30
4 & 6 cyl 7/1985 - 12/1987



ALUMINIUM / PLASTIC
AUTOMATIC

Core Height	550mm	Core Width	430mm
Core Thickness	32mm 1 Row	Inlet / Outlet	40 / 40
Oil Cooler	210mm		
Condenser		Receiver Drier	RDX043

Notes:

BMW11571

To suit BMW 318i E30, E36
4 cyl 1.8 & 1.9L 11/1988 - 2/2002



ALUMINIUM / PLASTIC
AUTOMATIC

Core Height	440mm	Core Width	435mm
Core Thickness	34mm 1 Row	Inlet / Outlet	40 / 40
Oil Cooler	210mm		
Condenser	CNX620 / CNX633	Receiver Drier	RDX045

Notes:

BMW54031

To suit BMW 320d, 335i E90, E91
4 & 6 cyl Turbo Diesel & Petrol 2/2006 >



ALUMINIUM / PLASTIC
AUTOMATIC

Core Height	600mm	Core Width	340mm
Core Thickness	34mm 1 Row	Inlet / Outlet	38 / 38
Oil Cooler	N/A		
Condenser	CNX697	Receiver Drier	RDX058

Notes:

D1CA

To suit BMW 320i, 323i, 325i, 330i, 335i
E90, E91, E92, E93
4 & 6 cyl inc Turbo 5/2005 >



ALUMINIUM / PLASTIC
AUTOMATIC

Core Height	600mm	Core Width	460mm
Core Thickness	30mm 1 Row	Inlet / Outlet	38 / 38
Oil Cooler	N/A		
Condenser	CNX697	Receiver Drier	RDX058

Notes:

D1CM

To suit BMW 320i, 323i, 325i
E90, E91, E92, E93
4 & 6 cyl 5/2005 >



ALUMINIUM / PLASTIC
MANUAL

Core Height	600mm	Core Width	460mm
Core Thickness	30mm 1 Row	Inlet / Outlet	38 / 38
Oil Cooler	N/A		
Condenser		Receiver Drier	

Notes:

BMW54071

To suit BMW 320i, 323i, 325i,
330i, 335i E90, E91, E92, E93
4 & 6 cyl inc Turbo 5/2005 >



ALUMINIUM / PLASTIC
AUTOMATIC

Core Height	600mm	Core Width	455mm
Core Thickness	34mm 1 Row	Inlet / Outlet	38 / 38
Oil Cooler	N/A		
Condenser	CNX697	Receiver Drier	RDX058

Notes: Open Pipe at the bottom of L/H tank.

BMW54061

To suit BMW 320i, 323i, 325i
E90, E91, E92, E93
4 & 6 cyl 5/2005 >



ALUMINIUM / PLASTIC
MANUAL

Core Height	600mm	Core Width	450mm
Core Thickness	32mm 1 Row	Inlet / Outlet	38 / 38
Oil Cooler	N/A		
Condenser		Receiver Drier	

Notes:

BMW11571

To suit BMW 320i, 323i, 325i, 328i E36
6 cyl 2.0 2.5 & 2.8L 5/1991 - 9/2000



ALUMINIUM / PLASTIC
AUTOMATIC

Core Height	440mm	Core Width	435mm
Core Thickness	34mm 1 Row	Inlet / Outlet	40 / 40
Oil Cooler	210mm		
Condenser	CNX620 / CNX633	Receiver Drier	RDX045

BMW13091

To suit BMW 320i, 323i, 325i, 328i E36
6 cyl 2.0 2.5 & 2.8L 5/1991 - 9/2000



ALUMINIUM / PLASTIC
MANUAL

Core Height	550mm	Core Width	435mm
Core Thickness	32mm 1 Row	Inlet / Outlet	40 / 40
Oil Cooler	N/A		
Condenser	CNX621	Receiver Drier	RDX047

Notes:

BMW13121

To suit BMW 320i, 323i, 325i E30
6 cyl 2.0 2.3 & 2.5L 2/1988 - 5/1994



ALUMINIUM / PLASTIC
MANUAL

Core Height	440mm	Core Width	435mm
Core Thickness	32mm 1 Row	Inlet / Outlet	40 / 40
Oil Cooler	N/A		
Condenser	CNX620	Receiver Drier	RDX045

Notes:

BMW10611

To suit BMW 320i E30
6 cyl 2.0L 2/1998 - 2/1991



ALUMINIUM / PLASTIC
AUTOMATIC

Core Height	550mm	Core Width	450mm
Core Thickness	36mm 2 Row	Inlet / Outlet	36 / 36
Oil Cooler	295mm		
Condenser	CNX621	Receiver Drier	RDX047

Notes:

BMW10611

To suit BMW 325e, 325i, 325is E30
6 cyl 2.5 & 2.7L 1/1986 - 5/1994



ALUMINIUM / PLASTIC
AUTOMATIC

Core Height	550mm	Core Width	450mm
Core Thickness	36mm 2 Row	Inlet / Outlet	36 / 36
Oil Cooler	295mm		
Condenser	CNX621	Receiver Drier	RDX047

Notes:

BMW13191

To suit BMW 325e E30
6 cyl 2.7L 1/1986 - 12/1987



ALUMINIUM / PLASTIC
AUTOMATIC

Core Height	550mm	Core Width	450mm
Core Thickness	48mm 2 Row	Inlet / Outlet	35 / 35
Oil Cooler	295mm		
Condenser		Receiver Drier	

Notes:

BMW19131

To suit BMW 335i, 523 - 550i E39, E60, E93
6 cyl & V8 inc Turbo 1/2001 - 1/2008



ALL ALUMINIUM
AUTOMATIC & MANUAL

Core Height	620mm	Core Width	488mm
Core Thickness	32mm 1 Row	Inlet / Outlet	38 / 38
Oil Cooler	N/A		
Condenser	CNX697 / CNX620	Receiver Drier	RDX051

Notes:

BMW55381

To suit BMW 520d 528i 535d 535i 550i
4 & 6 cyl Turbo Diesel & Petrol 2/2010 >



ALL ALUMINIUM
MANUAL

Core Height	600mm	Core Width	326mm
Core Thickness	32mm	Inlet / Outlet	41 / 41
Oil Cooler	N/A		
Condenser		Receiver Drier	

Notes:

BMW13191

To suit BMW 520i 525e E28
6 cyl 2.0 & 2.7L 3/1983 - 8/1988



ALUMINIUM / PLASTIC
AUTOMATIC

Core Height	623mm	Core Width	450mm
Core Thickness	48mm 2 Row	Inlet / Outlet	35 / 35
Oil Cooler	295mm		
Condenser	CNX624	Receiver Drier	RDX042 / RDX043

Notes:

BMW13101

To suit BMW 520i, 525i E34
6 cyl 2.0 & 2.5L 11/1990 - 9/1996



Core Height	520mm	Core Width	435mm
Core Thickness	29mm 1 Row	Inlet / Outlet	40 / 40
Oil Cooler	210mm		
Condenser	CNX625	Receiver Drier	RDX044

Notes:

BMW12231

To suit BMW 523i, 525i, 528i E39
6 cyl 2.5 & 2.8L 5/1996 - 10/2003



Core Height	650mm	Core Width	435mm
Core Thickness	43mm 1 Row	Inlet / Outlet	42 / 42
Oil Cooler	N/A		
Condenser	CNX620	Receiver Drier	RDX051

Notes:

BMW18001

To suit BMW 523i, 525i, 530i, 545i E60
6 cyl & V8 10/2003 - 5/2006



Core Height	620mm	Core Width	488mm
Core Thickness	40mm 1 Row	Inlet / Outlet	38 / 38
Oil Cooler	N/A		
Condenser	CNX694	Receiver Drier	CNX054

Notes:

BMW45761

To suit BMW 525i, 530i E60
6 cyl 6/2005 - 10/2008



Core Height	610mm	Core Width	485mm
Core Thickness	32mm 1 Row	Inlet / Outlet	38 / 38
Oil Cooler	N/A		
Condenser	CNX694	Receiver Drier	CNX054

Notes:

BMW13081

To suit BMW 525i E34
6 cyl 2.5L 9/1998 - 12/1992



Core Height	520mm	Core Width	435mm
Core Thickness	29mm 1 Row	Inlet / Outlet	41 / 41
Oil Cooler	N/A		
Condenser		Receiver Drier	RDX044

Notes:

BMW10301

To suit BMW 525i E39
6 cyl 2.5L Petrol & Diesel 1/2001 - 10/2003



Core Height	650mm	Core Width	435mm
Core Thickness	29mm 1 Row	Inlet / Outlet	30 / 30
Oil Cooler	210mm		
Condenser	CNX620	Receiver Drier	RDX045

Notes:

BMW11501

To suit BMW 530i E34
V8 3.0L 5sp 5/1993 - 12/1996

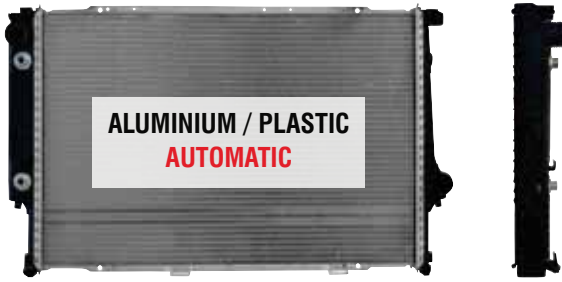

Core Height	650mm	Core Width	435mm
Core Thickness	34mm 1 Row	Inlet / Outlet	40 / 40
Oil Cooler	210mm		
Condenser	CNX625	Receiver Drier	

Notes:

BMW13091

To suit BMW 530i E34
V8 3.0L 5/1993 - 12/1996



Core Height	550mm	Core Width	435mm
Core Thickness	32mm 1 Row	Inlet / Outlet	40 / 40
Oil Cooler	N/A		
Condenser	CNX621	Receiver Drier	RDX047

Notes:

BMW12511

To suit BMW 530i, 540i E34
V8 3.0 & 4.0L 5/1993 - 12/1996



Core Height	650mm	Core Width	440mm
Core Thickness	42mm 1 Row	Inlet / Outlet	38 / 38
Oil Cooler	N/A		
Condenser	CNX625	Receiver Drier	RDX044

Notes:

BMW12511

To suit BMW 535i, 540i E39
V8 3.5 & 4.4L 12/1996 - 10/2003



Core Height	650mm	Core Width	440mm
Core Thickness	42mm 1 Row	Inlet / Outlet	38 / 38
Oil Cooler	N/A		
Condenser	CNX620	Receiver Drier	RDX051

Notes:

BMW12491

To suit BMW 535i, 540i E39
V8 3.5 4.0 & 4.4L 11/1994 - 10/2003



Core Height	650mm	Core Width	435mm
Core Thickness	35mm 1 Row	Inlet / Outlet	42 / 42
Oil Cooler	N/A		
Condenser	CNX620	Receiver Drier	RDX051

Notes: Clip on Fittings

BMW13071

To suit BMW 535i E34
6 cyl 3.4L 9/1988 - 5/1994



Core Height	610mm	Core Width	430mm
Core Thickness	34mm 1 Row	Inlet / Outlet	40 / 40
Oil Cooler	210mm		
Condenser	CNX625	Receiver Drier	RDX044

Notes:

BMW12231

To suit BMW 540i E39
V8 4.4L 12/1996 - 10/2003



Core Height	650mm	Core Width	435mm
Core Thickness	43mm 1 Row	Inlet / Outlet	42 / 42
Oil Cooler	N/A		
Condenser	CNX620	Receiver Drier	RDX051

Notes:

BMW18001

To suit BMW 645ci, 650i E63
V8 4.4L 2/2004 - 9/2007



Core Height	620mm	Core Width	488mm
Core Thickness	40mm 1 Row	Inlet / Outlet	38 / 38
Oil Cooler	N/A		
Condenser	CNX694	Receiver Drier	

Notes:

BMW19131

To suit BMW 650i E63, E64
V8 4.8L 1/2001 - 3/2009



Core Height	620mm	Core Width	488mm
Core Thickness	32mm 1 Row	Inlet / Outlet	38 / 38
Oil Cooler	N/A		
Condenser		Receiver Drier	

Notes:

BMW13071

To suit BMW 730i, 735i, 735iL
6 cyl 3.0 & 3.4L 3/1987 - 1/1993



Core Height	610mm	Core Width	430mm
Core Thickness	34mm 1 Row	Inlet / Outlet	40 / 40
Oil Cooler	210mm		
Condenser	CNX625	Receiver Drier	RDX044

Notes:

BMW12511

To suit BMW 730iL, 735i, 735iL E38
V8 3.0 3.5 4.0 & 4.4L 1/1993 - 2/2002



Core Height	650mm	Core Width	440mm
Core Thickness	42mm 1 Row	Inlet / Outlet	38 / 38
Oil Cooler	N/A		
Condenser	CNX818	Receiver Drier	RDX046

Notes:

BMW11501

To suit BMW 730iL E32, E38
V8 3.0L 10/1992 - 6/1997



Core Height	650mm	Core Width	435mm
Core Thickness	34mm 1 Row	Inlet / Outlet	40 / 40
Oil Cooler	210mm		
Condenser	CNX625 / CNX818	Receiver Drier	RDX044 / RDX046

Notes:

BMW13091

To suit BMW 730iL E32
V8 3.0L 10/1992 - 2/1995



ALUMINIUM / PLASTIC
MANUAL

Core Height	550mm	Core Width	435mm
Core Thickness	32mm 1 Row	Inlet / Outlet	40 / 40
Oil Cooler	N/A		
Condenser	CNX621	Receiver Drier	RDX047

Notes:

BMW12491

To suit BMW 735i, 735iL, 740iL E38
V8 3.5 & 4.4L 6/1996 - 2/2002



ALUMINIUM / PLASTIC
AUTOMATIC & MANUAL

Core Height	650mm	Core Width	435mm
Core Thickness	35mm 1 Row	Inlet / Outlet	42 / 42
Oil Cooler	N/A		
Condenser	CNX818	Receiver Drier	RDX046

Notes: Clip on Fittings

BMW12231

To suit BMW 735i, 740iL E38
V8 3.5 4.0 & 4.4L 6/1996 - 2/2002



ALUMINIUM / PLASTIC
AUTOMATIC & MANUAL

Core Height	650mm	Core Width	435mm
Core Thickness	43mm 1 Row	Inlet / Outlet	42 / 42
Oil Cooler	N/A		
Condenser	CNX818	Receiver Drier	RDX046

Notes:

BMW18001

To suit BMW 735i, 745i, 750iL, 760iL
E65, E66
V8 & V12 2/2002 - 3/2009



ALL ALUMINIUM
AUTOMATIC

Core Height	620mm	Core Width	488mm
Core Thickness	40mm 1 Row	Inlet / Outlet	38 / 38
Oil Cooler	N/A		
Condenser	CNX694	Receiver Drier	

Notes:

BMW19131

To suit BMW 735Li, 740Li, 745i, 750i, 750Li
E32, E65, E66
V8 & V12 2/2002 - 3/2009



ALL ALUMINIUM
AUTOMATIC & MANUAL

Core Height	620mm	Core Width	488mm
Core Thickness	32mm 1 Row	Inlet / Outlet	38 / 38
Oil Cooler	N/A		
Condenser	CNX818 / CNX887	Receiver Drier	RDX046

Notes:

BMW55381

To suit BMW 740i, 740iL, 760iL E66
6 cyl V8 & V12 3/2005 >



ALL ALUMINIUM
MANUAL

Core Height	600mm	Core Width	326mm
Core Thickness	32mm	Inlet / Outlet	39 / 39
Oil Cooler	N/A		
Condenser	CNX818	Receiver Drier	RDX046

Notes:

BMW12511

To suit BMW 740iL 750iL E38 L7
V8 4.0L & V12 5.4L 10/1992 - 1/2002



ALUMINIUM / PLASTIC
AUTOMATIC

Core Height	650mm	Core Width	440mm
Core Thickness	42mm 1 Row	Inlet / Outlet	38 / 38
Oil Cooler	N/A		
Condenser	CNX818	Receiver Drier	RDX046

Notes:

BMW12231

To suit BMW 750iL L7 E38
V12 5.4L 5/1995 - 1/2002



ALUMINIUM / PLASTIC
AUTOMATIC & MANUAL

Core Height	650mm	Core Width	435mm
Core Thickness	43mm 1 Row	Inlet / Outlet	42 / 42
Oil Cooler	N/A		
Condenser	CNX818	Receiver Drier	RDX046

Notes:

BMW12501

To suit BMW 750iL L7 E38
V12 5.4L 5/1995 - 1/2002



ALUMINIUM / PLASTIC
AUTOMATIC & MANUAL

Core Height	650mm	Core Width	440mm
Core Thickness	42mm 1 Row	Inlet / Outlet	38 / 38
Oil Cooler	N/A		
Condenser	CNX818	Receiver Drier	RDX046

Notes: Clip on Fittings

BMW13121

To suit BMW M3 E36
6 cyl 2.0L 4/1995 - 4/1997



ALUMINIUM / PLASTIC
MANUAL

Core Height	440mm	Core Width	435mm
Core Thickness	32mm 1 Row	Inlet / Outlet	40 / 40
Oil Cooler	N/A		
Condenser	CNX620	Receiver Drier	RDX045

Notes:

BMW12211

To suit BMW M3 E36
6 cyl 3.2L 4/1996 - 12/2002



ALUMINIUM / PLASTIC
MANUAL

Core Height	545mm	Core Width	410mm
Core Thickness	43mm 1 Row	Inlet / Outlet	40 / 40
Oil Cooler	N/A		
Condenser	CNX623	Receiver Drier	RDX045

Notes:

BMW13091

To suit BMW M3 E36
6 cyl 3.2L 5/1999 - 12/2002



ALUMINIUM / PLASTIC
MANUAL

Core Height	550mm	Core Width	435mm
Core Thickness	32mm 1 Row	Inlet / Outlet	40 / 40
Oil Cooler	N/A		
Condenser	CNX621	Receiver Drier	RDX047

Notes:

BMW16241

To suit BMW M3 E46
6 cyl 1/2001 - 9/2006



ALUMINIUM / PLASTIC
MANUAL

Core Height	580mm	Core Width	445mm
Core Thickness	29mm 1 Row	Inlet / Outlet	38 / 38
Oil Cooler	N/A		
Condenser	CNX630	Receiver Drier	RDX055

Notes: Clip on Fittings. Closed pipe at lower left tank

D1CA

To suit BMW M3 E90
V8 4.0L 11/2000 >



ALUMINIUM / PLASTIC
AUTOMATIC

Core Height	600mm	Core Width	460mm
Core Thickness	30mm 1 Row	Inlet / Outlet	38 / 38
Oil Cooler	N/A		
Condenser	CNX697	Receiver Drier	RDX058

Notes:

BMW54071

To suit BMW M3 E90
V8 4.0L 11/2010 >



ALUMINIUM / PLASTIC
AUTOMATIC

Core Height	600mm	Core Width	455mm
Core Thickness	34mm 1 Row	Inlet / Outlet	38 / 38
Oil Cooler	N/A		
Condenser	CNX697	Receiver Drier	RDX058

Notes: Open Pipe at the bottom of L/H tank.

BMW12501

To suit BMW M5 E39
V8 4.9L 5/1999 - 10/2003



ALUMINIUM / PLASTIC
AUTOMATIC & MANUAL

Core Height	650mm	Core Width	440mm
Core Thickness	42mm 1 Row	Inlet / Outlet	38 / 38
Oil Cooler	N/A		
Condenser		Receiver Drier	

Notes: Clip on Fittings

BMW54071

To suit BMW X1 E84
6 cyl 3/2010 >



ALUMINIUM / PLASTIC
AUTOMATIC

Core Height	600mm	Core Width	455mm
Core Thickness	34mm 1 Row	Inlet / Outlet	38 / 38
Oil Cooler	N/A		
Condenser	CNX697	Receiver Drier	RDX058

Notes: Open Pipe at the bottom of L/H tank.

BMW12211

To suit BMW X3 E83
6 cyl 2.5L 5/2004 - 10/2006



ALUMINIUM / PLASTIC
MANUAL

Core Height	545mm	Core Width	410mm
Core Thickness	43mm 1 Row	Inlet / Outlet	40 / 40
Oil Cooler	N/A		
Condenser	CNX639	Receiver Drier	RDX057

Notes:

BMW18751

To suit BMW X3 E83
6 cyl Turbo Diesel 12/2005 - 12/2008



ALUMINIUM / PLASTIC
AUTOMATIC & MANUAL

Core Height	595mm	Core Width	595mm
Core Thickness	40mm 1 Row	Inlet / Outlet	38 / 38
Oil Cooler	N/A		
Condenser	CNX632 / CNX638	Receiver Drier	RDX057

Notes: Clip on Fittings

BMW18751

To suit BMW X5 E53
6 cyl & V8 Petrol & Turbo Diesel 3/2001 - 3/2007



ALUMINIUM / PLASTIC
AUTOMATIC & MANUAL

Core Height	595mm	Core Width	595mm
Core Thickness	40mm 1 Row	Inlet / Outlet	38 / 38
Oil Cooler	N/A		
Condenser	CNX632 / CNX638	Receiver Drier	RDX057

Notes: Clip on Fittings

BMW18751

To suit BMW X6 E71
6 cyl & V8 Turbo Petrol & Diesel 2/2008 >



ALUMINIUM / PLASTIC
AUTOMATIC & MANUAL

Core Height	595mm	Core Width	595mm
Core Thickness	40mm 1 Row	Inlet / Outlet	38 / 38
Oil Cooler	N/A		
Condenser	CNX632 / CNX638	Receiver Drier	RDX057

Notes: Clip on Fittings

BMW13251

To suit BMW Z3 E36
4 & 6 cyl 1/1997 - 3/2003



ALUMINIUM / PLASTIC
AUTOMATIC

Core Height	550mm	Core Width	430mm
Core Thickness	32mm 1 Row	Inlet / Outlet	40 / 40
Oil Cooler	210mm		
Condenser	CNX623	Receiver Drier	RDX043

Notes:

BMW11571

To suit BMW Z3 E36
4 cyl 1.9L & 6 cyl 2.0, 2.2, 2.8 & 3.0L
1/1997 - 3/2003



ALUMINIUM / PLASTIC
AUTOMATIC

Core Height	440mm	Core Width	435mm
Core Thickness	34mm 1 Row	Inlet / Outlet	40 / 40
Oil Cooler	210mm		
Condenser	CNX620 / CNX633	Receiver Drier	RDX045

Notes:

BMW13121

To suit BMW Z3 E36
4 cyl 1.9L 6 cyl 2.0, 2.2, 2.8 & 3.0L
1/1997 - 3/2003



ALUMINIUM / PLASTIC
MANUAL

Core Height	440mm	Core Width	435mm
Core Thickness	32mm 1 Row	Inlet / Outlet	40 / 40
Oil Cooler	N/A		
Condenser	CNX620	Receiver Drier	RDX045

Notes:

BMW16251

To suit BMW Z4 E85, E86, E89
6 cyl 1/2003 - 5/2010



ALUMINIUM / PLASTIC
AUTOMATIC

Core Height	580mm	Core Width	445mm
Core Thickness	30mm 1 Row	Inlet / Outlet	38 / 38
Oil Cooler	N/A		
Condenser	CNX630	Receiver Drier	RDX055

Notes: Clip on Fittings. Open pipe on bottom right tank

BMW16271

To suit BMW Z4 E85, E86, E89
6 cyl 1/2003 - 5/2010



ALUMINIUM / PLASTIC
AUTOMATIC

Core Height	580mm	Core Width	445mm
Core Thickness	34mm 1 Row	Inlet / Outlet	38 / 38
Oil Cooler	N/A		
Condenser		Receiver Drier	

Notes: Clip on Fittings. Open pipe on bottom tank

BMW16241

To suit BMW Z4 E85, E86, E89
6 cyl 3/2003 - 5/2010



ALUMINIUM / PLASTIC
MANUAL

Core Height	580mm	Core Width	445mm
Core Thickness	29mm 1 Row	Inlet / Outlet	38 / 38
Oil Cooler	N/A		
Condenser	CNX630	Receiver Drier	RDX055

Notes: Clip on Fittings. Closed pipe at lower left tank for M/T

CHR31150

To suit Chrysler 300C
V6 V8 Petrol & Diesel 11/2005 >



ALUMINIUM / PLASTIC
AUTOMATIC

Core Height	615mm	Core Width	740mm
Core Thickness	32mm 1 Row	Inlet / Outlet	38 / 38
Oil Cooler	N/A		
Condenser	CNX828	Receiver Drier	

Notes: External Oil Cooler

CHR1111

To suit Chrysler Grand Voyager RG
4 cyl Diesel & V6 3.3L Petrol 6/2001 >



ALUMINIUM / PLASTIC
AUTOMATIC

Core Height	770mm	Core Width	415mm
Core Thickness	26mm 1 Row	Inlet / Outlet	40 / 40
Oil Cooler	N/A		
Condenser	CNX656 / CNX653	Receiver Drier	

Notes:

J54CA

To suit Chrysler Neon
4 cyl 1.8 & 2.0L 8/1996 - 9/1999



ALUMINIUM / PLASTIC
AUTOMATIC

Core Height	300mm	Core Width	600mm
Core Thickness	16mm 1 Row	Inlet / Outlet	33 / 33
Oil Cooler	300mm		
Condenser	CNX650	Receiver Drier	RDX903

Notes:

CHR31145

To suit Chrysler PT Cruiser
4 cyl 2.0 & 2.4L 7/2000 - 11/2004



Core Height	460mm	Core Width	508mm
Core Thickness	24mm 1 Row	Inlet / Outlet	33 / 35
Oil Cooler	325mm		
Condenser	CNX652	Receiver Drier	RDX395

Notes:

CHR31140

To suit Chrysler Voyager GS
V6 3.3L 2/1997 - 6/2002



Core Height	663mm	Core Width	380mm
Core Thickness	35mm 2 Row	Inlet / Outlet	33 / 39
Oil Cooler	305/255mm		
Condenser	CNX651	Receiver Drier	RDX906

Notes: Twin Oil Coolers

CHR1112

To suit Chrysler Voyager RG
V6 3.3L 6/2001 - 2005



Core Height	770mm	Core Width	415mm
Core Thickness	34mm 1 Row	Inlet / Outlet	40 / 40
Oil Cooler	N/A		
Condenser	CNX653	Receiver Drier	

Notes:

CHR1111

To suit Chrysler Voyager RG
V6 3.3L 6/2001 >



Core Height	770mm	Core Width	415mm
Core Thickness	26mm 1 Row	Inlet / Outlet	40 / 40
Oil Cooler	N/A		
Condenser	CNX653	Receiver Drier	

Notes:

CIT19511

To suit Citroen Berlingo JP GJ KF
4 cyl 1.4 & 1.6L 7/1999 >



Core Height	610mm	Core Width	377mm
Core Thickness	23mm 1 Row	Inlet / Outlet	40 / 45
Oil Cooler	N/A		
Condenser	CNX912	Receiver Drier	RDX245

Notes:

PEU10261

To suit Citroen Xsara TU5JP4
4 cyl 1.6L 2/2001 - 3/2006



Core Height	640mm	Core Width	383mm
Core Thickness	36mm 2 Row	Inlet / Outlet	40 / 40
Oil Cooler	N/A		
Condenser	CNX557	Receiver Drier	RDX242

Notes:

DAE0001

To suit Daewoo Cielo
4 cyl 1.5L 9/1995 - 6/1998



Core Height	635mm	Core Width	380mm
Core Thickness	24mm 1 Row	Inlet / Outlet	33 / 33
Oil Cooler	245mm		
Condenser	CNX152	Receiver Drier	RDX453

Notes:

DAE1001

To suit Daewoo Cielo
4cyl 1.5L 9/1995 - 6/1998



Core Height	635mm	Core Width	380mm
Core Thickness	24mm 1 Row	Inlet / Outlet	33 / 33
Oil Cooler	N/A		
Condenser	CNX152	Receiver Drier	RDX453

Notes: Sender Port Drivers Side Top Tank

DAE0002

To suit Daewoo Espero
4 cyl 2.0L 3/1995 - 8/1997



Core Height	635mm	Core Width	385mm
Core Thickness	24mm 1 Row	Inlet / Outlet	34 / 34
Oil Cooler	N/A		
Condenser	CNX152	Receiver Drier	RDX453

Notes: Sender Port Drivers Side Top Tank

DAE1002

To suit Daewoo Espero
4 cyl 2.0L 3/1995 - 8/1997



Core Height	635mm	Core Width	380mm
Core Thickness	24mm 1 Row	Inlet / Outlet	33 / 33
Oil Cooler	N/A		
Condenser	CNX152	Receiver Drier	RDX453

Notes: Sender Port Drivers Side Top Tank

DAE0003

To suit Daewoo Kalos T200
4 cyl 1.5L 4/2003 - 5/2005



Core Height	600mm	Core Width	410mm
Core Thickness	16mm 1 Row	Inlet / Outlet	34 / 34
Oil Cooler	250mm		
Condenser	CNX158	Receiver Drier	

Notes:

DAE1009

To suit Daewoo Kalos T200
4 cyl 1.5L 4/2003 - 5/2005



Core Height	480mm	Core Width	410mm
Core Thickness	16mm 1 Row	Inlet / Outlet	34 / 34
Oil Cooler	N/A		
Condenser	CNX158	Receiver Drier	

Notes:

DAE0004

To suit Daewoo Lacetti J200
4 cyl 1.8L 9/2003 - 1/2005



ALUMINIUM / PLASTIC
AUTOMATIC

Core Height	375mm	Core Width	700mm
Core Thickness	16mm 1 Row	Inlet / Outlet	34 / 34
Oil Cooler	290mm		
Condenser		Receiver Drier	RDX164

Notes:

DAE1004

To suit Daewoo Lacetti J200
4 cyl 1.8L 9/2003 - 1/2005



ALUMINIUM / PLASTIC
MANUAL

Core Height	375mm	Core Width	700mm
Core Thickness	16mm 2 Row	Inlet / Outlet	34 / 34
Oil Cooler	N/A		
Condenser		Receiver Drier	RDX164

Notes:

DAE0005

To suit Daewoo Lanos
4 cyl 1.5 & 1.6L 8/1997 - 9/2003



ALUMINIUM / PLASTIC
AUTOMATIC

Core Height	635mm	Core Width	375mm
Core Thickness	16mm 1 Row	Inlet / Outlet	34 / 34
Oil Cooler	250mm		
Condenser	CNX154	Receiver Drier	RDX451

Notes:

DAE1005

To suit Daewoo Lanos
4 cyl 1.5 & 1.6L 8/1997 - 9/2003



ALUMINIUM / PLASTIC
MANUAL

Core Height	635mm	Core Width	380mm
Core Thickness	16mm 1 Row	Inlet / Outlet	34 / 34
Oil Cooler	N/A		
Condenser	CNX154	Receiver Drier	RDX451

Notes:

DAE0006

To suit Daewoo Leganza
4 cyl 2.0 & 2.2L 8/1997 - 1/2005



ALUMINIUM / PLASTIC
AUTOMATIC

Core Height	655mm	Core Width	383mm
Core Thickness	16mm 1 Row	Inlet / Outlet	34 / 34
Oil Cooler	N/A		
Condenser	CNX153	Receiver Drier	RDX452

Notes: Round Mount

DAE1006

To suit Daewoo Leganza
4 cyl 2.0 & 2.2L 8/1997 - 1/2005



ALUMINIUM / PLASTIC
MANUAL

Core Height	655mm	Core Width	383mm
Core Thickness	16mm 1 Row	Inlet / Outlet	34 / 34
Oil Cooler	N/A		
Condenser	CNX153	Receiver Drier	RDX452

Notes: Round Mount

DAE0007

To suit Daewoo Matiz
3 cyl 0.8L 7/2002 - 1/2005



Core Height	460mm	Core Width	290mm
Core Thickness	28mm 1 Row	Inlet / Outlet	28 / 28
Oil Cooler	200mm		
Condenser	CNX157 / CNX213	Receiver Drier	RDX162

Notes:

DAE1007

To suit Daewoo Matiz
3 cyl 0.8L 10/1999 - 1/2005



Core Height	460mm	Core Width	290mm
Core Thickness	28mm 1 Row	Inlet / Outlet	28 / 28
Oil Cooler	N/A		
Condenser	CNX157 / CNX213	Receiver Drier	RDX162

Notes:

DAE0008

To suit Daewoo Nubira
4 cyl 1.6 & 2.0L 7/1997 - 12/2005



Core Height	655mm	Core Width	375mm
Core Thickness	16mm 1 Row	Inlet / Outlet	33 / 33
Oil Cooler	250mm		
Condenser	CNX155	Receiver Drier	RDX452

Notes: Square Mount

DAE1008

To suit Daewoo Nubira
4 cyl 1.6 & 2.0L 7/1997 - 12/2005



Core Height	655mm	Core Width	375mm
Core Thickness	16mm 1 Row	Inlet / Outlet	33 / 33
Oil Cooler	N/A		
Condenser	CNX155	Receiver Drier	RDX452

Notes: Square Mount

DAE0006

To suit Daewoo Nubira
4 cyl 2.0L 4/1998 - 12/2005



Core Height	655mm	Core Width	383mm
Core Thickness	16mm 1 Row	Inlet / Outlet	34 / 34
Oil Cooler	N/A		
Condenser	CNX153	Receiver Drier	RDX452

Notes: Round Mount

DAE1006

To suit Daewoo Nubira
4 cyl 1.6 & 2.0L 7/1997 - 12/2005



Core Height	655mm	Core Width	383mm
Core Thickness	16mm 1 Row	Inlet / Outlet	34 / 34
Oil Cooler	N/A		
Condenser	CNX153	Receiver Drier	RDX452

Notes: Round Mount

DAE0004

To suit Daewoo Tacuma
4 cyl 2.0L 1/2000 - 1/2005



Core Height	375mm	Core Width	700mm
Core Thickness	16mm 1 Row	Inlet / Outlet	34 / 34
Oil Cooler	290mm		
Condenser		Receiver Drier	RDX7302

Notes:

DAE1004

To suit Daewoo Tacuma
4 cyl 2.0L 10/2000 - 1/2005



Core Height	375mm	Core Width	700mm
Core Thickness	16mm 1 Row	Inlet / Outlet	34 / 34
Oil Cooler	N/A		
Condenser		Receiver Drier	RDX7302

Notes:

DAF21511

To suit DAF CF85 FTT
6 cyl 12 & 13L inc Turbo 1/1987 - 1/2000



Core Height	970mm	Core Width	748mm
Core Thickness	42mm 3 Row	Inlet / Outlet	62 / 62
Oil Cooler	N/A		
Condenser		Receiver Drier	

Notes:

DAI1250

To suit Daihatsu Applause A101
4 cyl 1.6L 1993 - 1994



Core Height	330mm	Core Width	660mm
Core Thickness	26mm 1 Row	Inlet / Outlet	32 / 32
Oil Cooler	250mm		
Condenser	CNX9060	Receiver Drier	RDX282

Notes:

L5CM

To suit Daihatsu Applause A101
4 cyl 1.6L 10/1989 - 1/2000



Core Height	325mm	Core Width	641mm
Core Thickness	27mm 1 Row	Inlet / Outlet	33 / 33
Oil Cooler	N/A		
Condenser	CNX2130	Receiver Drier	RDX282

Notes:

L4CM

To suit Daihatsu Applause A101
4 cyl 1.6L 10/1989 - 1/2000



Core Height	325mm	Core Width	641mm
Core Thickness	16mm 1 Row	Inlet / Outlet	33 / 33
Oil Cooler	N/A		
Condenser	CNX2130	Receiver Drier	RDX282

Notes:

DAI1250

To suit Daihatsu Applause A101
4 cyl 1.6L 1993 - 1994



Core Height	330mm	Core Width	660mm
Core Thickness	26mm 1 Row	Inlet / Outlet	32 / 32
Oil Cooler	250mm		
Condenser	CNX9060	Receiver Drier	RDX282

Notes:

L40CA

To suit Daihatsu Charade L251S
3 cyl 1.0L 7/2003 - 3/2006



Core Height	400mm	Core Width	330mm
Core Thickness	21mm 1 Row	Inlet / Outlet	25 / 25
Oil Cooler	175mm		
Condenser	CNX8140	Receiver Drier	RDX0040

Notes:

L40CM

To suit Daihatsu Charade L251S
3 cyl 1.0L 7/2003 - 3/2006



Core Height	400mm	Core Width	330mm
Core Thickness	21mm 1 Row	Inlet / Outlet	25 / 25
Oil Cooler	N/A		
Condenser	CNX8140	Receiver Drier	RDX0040

Notes:

L5CM

To suit Daihatsu Charade G200 - G203
3 cyl 1.0L & 4 cyl 1.5L 1/1994 - 1/2000



Core Height	325mm	Core Width	641mm
Core Thickness	27mm 1 Row	Inlet / Outlet	33 / 33
Oil Cooler	N/A		
Condenser	CNX2130	Receiver Drier	RDX282

Notes:

L4CM

To suit Daihatsu Charade G200 - G203
3 cyl 1.0L & 4 cyl 1.5L 1/1994 - 1/2000



Core Height	325mm	Core Width	641mm
Core Thickness	16mm 1 Row	Inlet / Outlet	33 / 33
Oil Cooler	N/A		
Condenser	CNX2130	Receiver Drier	RDX282

Notes:

L39CM

To suit Daihatsu Charade Centro L500
3 cyl 0.7L 3/1995 - 6/1998



Core Height	350mm	Core Width	325mm
Core Thickness	27mm 1 Row	Inlet / Outlet	25 / 25
Oil Cooler	N/A		
Condenser		Receiver Drier	RDX604

Notes:

L9CM

To suit Daihatsu Charade G200 - 202
3 cyl 1.0L & 4 cyl 1.3L 5/1993 - 4/1998



Core Height	325mm	Core Width	355mm
Core Thickness	16mm 1 Row	Inlet / Outlet	32 / 32
Oil Cooler	N/A		
Condenser	CNX0860	Receiver Drier	RDX281

Notes:

DAI1178

To suit Daihatsu Charade G200 - G203
4 cyl 1.3 & 1.5L 1994 - 2000

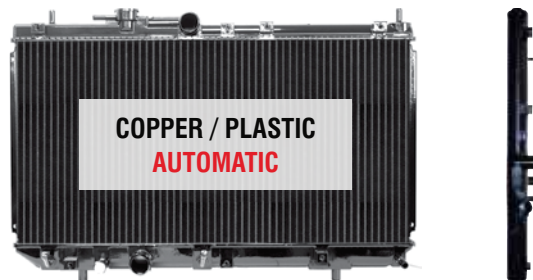

Core Height	325mm	Core Width	640mm
Core Thickness	32mm 2 Row	Inlet / Outlet	34 / 34
Oil Cooler	255mm		
Condenser	CNX0860 / CNX6420	Receiver Drier	RDX281

Notes:

DAI1253

To suit Daihatsu Charade G100 - G102
3 cyl 1.0 & 1.3L 1/1987 - 5/1994



Core Height	350mm	Core Width	390mm
Core Thickness	32mm 2 Row	Inlet / Outlet	33 / 33
Oil Cooler	225mm		
Condenser	CNX4463	Receiver Drier	RDX161

Notes:

L15CA

To suit Daihatsu Charade G100 - G102
3 cyl 1.0L 4 cyl 1.3L 1/1987 - 5/1994



Core Height	350mm	Core Width	390mm
Core Thickness	16mm 1 Row	Inlet / Outlet	26 / 26
Oil Cooler	200mm		
Condenser	CNX4463	Receiver Drier	RDX282

Notes:

L21CA

To suit Daihatsu Charade G102
4 cyl 1.3L 6/1987 - 7/1993



Core Height	350mm	Core Width	650mm
Core Thickness	16mm 1 Row	Inlet / Outlet	33 / 33
Oil Cooler	225mm		
Condenser		Receiver Drier	RDX281

Notes:

DAI1191

To suit Daihatsu Charade G100 - G102
3 cyl 1.0L 1/1987 - 12/1993



Core Height	350mm	Core Width	390mm
Core Thickness	16mm 1 Row	Inlet / Outlet	25 / 25
Oil Cooler	N/A		
Condenser	CNX4463	Receiver Drier	RDX161

Notes:

L13CM

To suit Daihatsu Charade G100 - G102
3 cyl 1.0L & 4 cyl 1.3L 1/1987 - 12/1993



Core Height	350mm	Core Width	330mm
Core Thickness	16mm 1 Row	Inlet / Outlet	25 / 25
Oil Cooler	N/A		
Condenser	CNX4463	Receiver Drier	RDX282

Notes:

DAI14052

To suit Daihatsu Charade G11
3 cyl 1.0L 4/1983 - 5/1988



Core Height	355mm	Core Width	330mm
Core Thickness	32mm 2 Row	Inlet / Outlet	26 / 26
Oil Cooler	N/A		
Condenser		Receiver Drier	RDX086

Notes:

DAI14050

To suit Daihatsu Charade G10
3 cyl 1.0L 4/1980 - 2/1984



Core Height	350mm	Core Width	310mm
Core Thickness	32mm 2 Row	Inlet / Outlet	26 / 26
Oil Cooler	N/A		
Condenser		Receiver Drier	RDX086

Notes:

DAI1199

To suit Daihatsu L200, L201 Mira J
3 cyl 0.7L 1992 - 1995



Core Height	350mm	Core Width	325mm
Core Thickness	16mm 1 Row	Inlet / Outlet	26 / 26
Oil Cooler	N/A		
Condenser		Receiver Drier	RDX282

Notes:

L39CM

To suit Daihatsu Move L601
3 cyl 0.8L 2/1997 - 1/2000



Core Height	350mm	Core Width	325mm
Core Thickness	27mm 1 Row	Inlet / Outlet	25 / 25
Oil Cooler	N/A		
Condenser		Receiver Drier	RDX604

Notes:

L5CM

To suit Daihatsu Pyzar G301 - G303
4 cyl 1.6L 2/1997 - 8/2000



Core Height	325mm	Core Width	641mm
Core Thickness	27mm 1 Row	Inlet / Outlet	33 / 33
Oil Cooler	N/A		
Condenser	CNX2130	Receiver Drier	RDX282

Notes:

L4CM

To suit Daihatsu Pyzar G301 - G303
4 cyl 1.6L 2/1997 - 8/2000



ALUMINIUM / PLASTIC
MANUAL

Core Height	325mm	Core Width	641mm
Core Thickness	16mm 1 Row	Inlet / Outlet	33 / 33
Oil Cooler	N/A		
Condenser	CNX2130	Receiver Drier	RDX281

Notes:

DAI1178

To suit Daihatsu Pyzar G301 - G303
4 cyl 1.5 & 1.6L 1994 - 2000

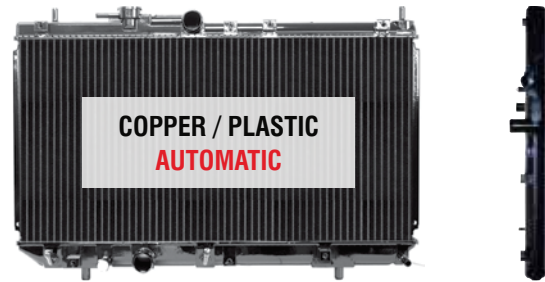

COPPER / PLASTIC
AUTOMATIC

Core Height	325mm	Core Width	640mm
Core Thickness	32mm 2 Row	Inlet / Outlet	34 / 34
Oil Cooler	255mm		
Condenser	CNX2130	Receiver Drier	RDX281

Notes:

L38CA

To suit Daihatsu Sirion M100 - M201
3 cyl 1.0L & 4 cyl 1.3L 6/1998 - 2/2006



ALUMINIUM / PLASTIC
AUTOMATIC

Core Height	375mm	Core Width	325mm
Core Thickness	27mm 1 Row	Inlet / Outlet	25 / 25
Oil Cooler	175mm		
Condenser	CNX9640	Receiver Drier	RDX0040

Notes:

L36CM

To suit Daihatsu Sirion M100 - M101
3 cyl 1.0L & 4 cyl 1.3L 6/1998 - 2/2006



ALUMINIUM / PLASTIC
MANUAL

Core Height	375mm	Core Width	325mm
Core Thickness	16mm 1 Row	Inlet / Outlet	25 / 25
Oil Cooler	N/A		
Condenser	CNX9640	Receiver Drier	RDX0040

Notes:

DAI14080

To suit Daihatsu Terios J100 - J102
4 cyl 1.3L 6/1997 - 12/2005



ALUMINIUM / PLASTIC
AUTOMATIC

Core Height	426mm	Core Width	578mm
Core Thickness	24mm 1 Row	Inlet / Outlet	32 / 32
Oil Cooler	375mm		
Condenser	CNX8260	Receiver Drier	RDX281

Notes:

DAI14082

To suit Daihatsu Terios J100 - J102
4 cyl 1.3L 6/1997 - 12/2005



ALUMINIUM / PLASTIC
MANUAL

Core Height	426mm	Core Width	578mm
Core Thickness	24mm 1 Row	Inlet / Outlet	32 / 32
Oil Cooler	N/A		
Condenser	CNX8260	Receiver Drier	RDX281

Notes:

L38CA

To suit Daihatsu YRV M201
4 cyl 1.3L 7/2001 -12/2004



Core Height	375mm	Core Width	325mm
Core Thickness	27mm 1 Row	Inlet / Outlet	25 / 25
Oil Cooler	175mm		
Condenser	CNX9640	Receiver Drier	RDX0040

Notes:

L36CM

To suit Daihatsu YRV M201
4 cyl 1.3L 7/2001 -12/2004



Core Height	375mm	Core Width	325mm
Core Thickness	16mm 1 Row	Inlet / Outlet	25 / 25
Oil Cooler	N/A		
Condenser	CNX9640	Receiver Drier	RDX0040

Notes:

NIS46000

To suit Datsun 120Y B210 A12
4 cyl 1.2L 3/1974 - 5/1980



Core Height	330mm	Core Width	340mm
Core Thickness	32mm 2 Row	Inlet / Outlet	29 / 29
Oil Cooler	N/A		
Condenser		Receiver Drier	

Notes:

NIS46002

To suit Datsun 120Y B210 A12
4 cyl 1.2L 3/1974 - 5/1980



Core Height	330mm	Core Width	340mm
Core Thickness	32mm 2 Row	Inlet / Outlet	29 / 29
Oil Cooler	N/A		
Condenser		Receiver Drier	

Notes:

MAZ40135

To suit Eunos 30X
V6 1.8L 11/1992 - 4/1998



Core Height	690mm	Core Width	348mm
Core Thickness	24mm 1 Row	Inlet / Outlet	36 / 36
Oil Cooler	225mm		
Condenser	CNX102	Receiver Drier	RDX087

Notes:

MAZ40135

To suit Eunos 500
V6 2.0L 11/1992 - 2/2000



Core Height	690mm	Core Width	348mm
Core Thickness	24mm 1 Row	Inlet / Outlet	36 / 36
Oil Cooler	225mm		
Condenser	CNX102	Receiver Drier	RDX087

Notes:

MAZ40135

To suit Eunos 800
V6 2.3 & 2.5L 3/1994 - 10/2000



Core Height	690mm	Core Width	348mm
Core Thickness	24mm 1 Row	Inlet / Outlet	36 / 36
Oil Cooler	225mm		
Condenser	CNX102	Receiver Drier	RDX087

Notes:

FIA17281

To suit Fiat Ducato
2.8L Turbo Diesel 1/2002 - 1/2008



Core Height	790mm	Core Width	417mm
Core Thickness	32mm 1 row	Inlet / Outlet	38 / 38
Oil Cooler	N/A		
Condenser	CNX915	Receiver Drier	

Notes:

FIA45111

To suit Fiat Ducato Sofim
4 cyl 3.0L Turbo Diesel 2/2007 >



Core Height	780mm	Core Width	375mm
Core Thickness	24mm	Inlet / Outlet	35 / 35
Oil Cooler	N/A		
Condenser		Receiver Drier	

Notes:

FOR003CA

To suit Ford Bronco
6 cyl & V8 (Cleveland & Windsor)
3/1981 - 12/1987



Core Height	697mm	Core Width	460mm
Core Thickness	46mm 3 Row	Inlet / Outlet	45 / 45
Oil Cooler	310mm		
Condenser		Receiver Drier	

Notes:

NIS40035

To suit Ford Corsair UA
4 cyl 2.0 & 2.4L 11/1989 - 12/1992



Core Height	380mm	Core Width	695mm
Core Thickness	24mm 1 Row	Inlet / Outlet	38 / 38
Oil Cooler	300mm		
Condenser	CNX017	Receiver Drier	RDX033

Notes:

FOR40318

To suit Ford Courier PG - PH
4 cyl 2.6L, V6 4.0L & 2.5L Turbo Diesel
5/1996 - 11/2006



Core Height	454mm	Core Width	648mm
Core Thickness	32mm 1 Row	Inlet / Outlet	35 / 35
Oil Cooler	375mm		
Condenser	CNX400 / CNX409	Receiver Drier	RDX0050 / RDX191

Notes: Multi-Fit

15-FOR40319

revolution

To suit Ford Courier PG - PH
4 cyl 2.6L & 2.5L Turbo Diesel 5/1996 - 11/2006



Core Height	454mm	Core Width	648mm
Core Thickness	32mm 1 Row	Inlet / Outlet	35 / 35
Oil Cooler	N/A		
Condenser	CNX400 / CNX409	Receiver Drier	RDX0050 / RDX191

Notes: Multi-Fit

FOR40319

OEX

To suit Ford Courier PG - PH
4 cyl 2.6L & 2.5L Turbo Diesel 5/1996 - 11/2006



Core Height	454mm	Core Width	648mm
Core Thickness	32mm 1 Row	Inlet / Outlet	35 / 35
Oil Cooler	N/A		
Condenser	CNX400 / CNX409	Receiver Drier	RDX0050 / RDX191

Notes: Multi-Fit

FOR40315

OEX

To suit Ford Courier PG - PH
4 cyl 2.6L & 2.5L Turbo Diesel 5/1996 - 11/2006



Core Height	454mm	Core Width	648mm
Core Thickness	24mm 1 Row	Inlet / Outlet	35 / 35
Oil Cooler	375mm		
Condenser	CNX400 / CNX409	Receiver Drier	RDX0050 / RDX191

Notes: Suits Thailand OE

FOR40316

OEX

To suit Ford Courier PG - PH
4 cyl 2.6L & 2.5L Turbo Diesel 5/1996 - 11/2006



Core Height	454mm	Core Width	648mm
Core Thickness	24mm 1 Row	Inlet / Outlet	35 / 35
Oil Cooler	N/A		
Condenser	CNX400 / CNX409	Receiver Drier	RDX0050 / RDX191

Notes: Suits Thailand OE

M32CM

DENSO

To suit Ford Courier PD - PH
4 cyl 2.6L & 2.5L Turbo Diesel 5/1996 - 11/2006



Core Height	450mm	Core Width	640mm
Core Thickness	27mm 1 Row	Inlet / Outlet	36 / 36
Oil Cooler	N/A		
Condenser	CNX400 / CNX409	Receiver Drier	RDX0050 / RDX191

Notes:

FOR43020

OEX

To suit Ford Courier PD - PE
4 cyl 2.6L 5/1996 - 11/2002



Core Height	400mm	Core Width	645mm
Core Thickness	32mm 1 Row	Inlet / Outlet	35 / 35
Oil Cooler	350mm		
Condenser	CNX400 / CNX409	Receiver Drier	RDX0050 / RDX191

Notes:

MAZ40400

To suit Ford Courier PD
4 cyl 2.6L 1/1992 - 2/2000



COPPER / BRASS
AUTOMATIC

Core Height	400mm	Core Width	640mm
Core Thickness	32mm 2 Row	Inlet / Outlet	36 / 36
Oil Cooler	350mm		
Condenser	CNX2860	Receiver Drier	RDX026

Notes:

FOR43022

To suit Ford Courier PC
4 cyl 2.6L 1/1990 - 5/1997



ALUMINIUM / PLASTIC
MANUAL

Core Height	400mm	Core Width	645mm
Core Thickness	32mm 1 Row	Inlet / Outlet	35 / 35
Oil Cooler	N/A		
Condenser	CNX2860	Receiver Drier	RDX026

Notes:

MAZ40430

To suit Ford Courier PC
4 cyl 2.6L & 2.2L Diesel 1/1988 - 5/1997



COPPER / BRASS
MANUAL

Core Height	375mm	Core Width	588mm
Core Thickness	32mm 2 Row	Inlet / Outlet	36 / 36
Oil Cooler	275mm		
Condenser	CNX019	Receiver Drier	RDX022

Notes:

MAZ40350

To suit Ford Courier PC - PD
4 cyl 2.0 & 2.6L Petrol 2.5L Diesel 6/1985 - 2/2000



COPPER / BRASS
MANUAL

Core Height	400mm	Core Width	640mm
Core Thickness	29mm 2 Row	Inlet / Outlet	36 / 36
Oil Cooler	N/A		
Condenser	CNX2860	Receiver Drier	RDX026

Notes:

M43CM

To suit Ford Econovan JH
4 cyl 1.8L 10/1999 - 1/2006



ALUMINIUM / PLASTIC
MANUAL

Core Height	350mm	Core Width	545mm
Core Thickness	16mm 1 Row	Inlet / Outlet	37 / 37
Oil Cooler	N/A		
Condenser	CNX410	Receiver Drier	RDX5810

Notes:

M38CM

To suit Ford Econovan E2000 JG
4 cyl 2.0L 2/1997 - 1/2000



ALUMINIUM / PLASTIC
MANUAL

Core Height	400mm	Core Width	565mm
Core Thickness	33mm 2 Row	Inlet / Outlet	36 / 36
Oil Cooler	N/A		
Condenser		Receiver Drier	

Notes:

M40CA

To suit Ford Econovan E2000 JG
4 cyl 2.0L 2/1997 - 1/2000



ALUMINIUM / PLASTIC
AUTOMATIC

Core Height	350mm	Core Width	545mm
Core Thickness	27mm 1 Row	Inlet / Outlet	35 / 35
Oil Cooler	225mm		
Condenser		Receiver Drier	

Notes:

M40CM

To suit Ford Econovan JE - JH
4 cyl 1.8 & 2.0L 2/1997 - 1/2006



ALUMINIUM / PLASTIC
MANUAL

Core Height	350mm	Core Width	545mm
Core Thickness	27mm 1 Row	Inlet / Outlet	35 / 35
Oil Cooler	N/A		
Condenser		Receiver Drier	

Notes:

G21CM

To suit Ford Econovan E2000 JG - JH
4 cyl 2.0L 2/1997 - 1/2006



ALUMINIUM / PLASTIC
MANUAL

Core Height	450mm	Core Width	640mm
Core Thickness	27mm 1 Row	Inlet / Outlet	35 / 35
Oil Cooler	N/A		
Condenser		Receiver Drier	

Notes:

FOR40210

To suit Ford Econovan E1800 E2000
4 cyl 1.8 & 2.0L 4/1984 - 1/2000



COPPER / BRASS
MANUAL

Core Height	350mm	Core Width	556mm
Core Thickness	45mm 3 Row	Inlet / Outlet	35 / 35
Oil Cooler	N/A		
Condenser	CNX401	Receiver Drier	

Notes:

FOR40200

To suit Ford Econovan E2200
4 cyl 2.2L Diesel 7/1981 - 4/1998



COPPER / BRASS
MANUAL

Core Height	350mm	Core Width	570mm
Core Thickness	49mm 3 Row	Inlet / Outlet	36 / 36
Oil Cooler	N/A		
Condenser		Receiver Drier	

Notes:

MAZ40420

To suit Ford Econovan
4 cyl 1.4 & 1.6L 6/1979 - 12/1985



COPPER / BRASS
MANUAL

Core Height	325mm	Core Width	450mm
Core Thickness	32mm 2 Row	Inlet / Outlet	36 / 37
Oil Cooler	N/A		
Condenser		Receiver Drier	

Notes:

MAZ1867

To suit Ford Escape ZB - ZD
4 cyl 2.3L 2/2004 - 4/2009

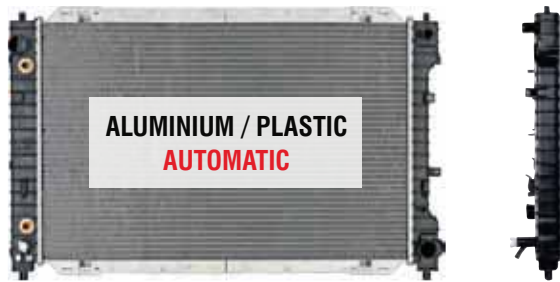

ALUMINIUM / PLASTIC
AUTOMATIC

Core Height	700mm	Core Width	452mm
Core Thickness	26mm 1 Row	Inlet / Outlet	12 / 20 / 35
Oil Cooler	305mm		
Condenser	CNX115	Receiver Drier	RDX183

Notes:

MAZ2437

To suit Ford Escape ZB - ZC
4 cyl 2.3L 2/2004 - 4/2009

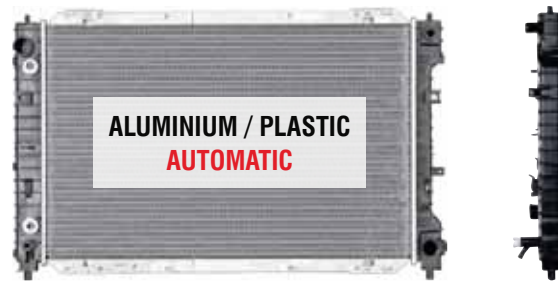

ALUMINIUM / PLASTIC
AUTOMATIC

Core Height	700mm	Core Width	452mm
Core Thickness	26mm 1 Row	Inlet / Outlet	12 / 20 / 35
Oil Cooler	305mm		
Condenser	CNX115	Receiver Drier	RDX183

Notes:

MAZ1866

To suit Ford Escape BA - ZC
V6 3.0L 3/2001 - 4/2009



ALUMINIUM / PLASTIC
AUTOMATIC

Core Height	700mm	Core Width	445mm
Core Thickness	25mm 1 Row	Inlet / Outlet	32 / 32
Oil Cooler	305mm		
Condenser	CNX115	Receiver Drier	RDX183

Notes:

FOR1949

To suit Ford Explorer US - UZ
V6 & V8 4.0 & 4.6L 10/1996 - 1/2008



ALUMINIUM / PLASTIC
MANUAL

Core Height	540mm	Core Width	600mm
Core Thickness	34mm 1 Row	Inlet / Outlet	38 / 38
Oil Cooler	N/A		
Condenser		Receiver Drier	RDX755

Notes: External Oil Cooler to suit V8

FOR1824

To suit Ford Explorer UN - US
V6 4.0L 11/1996 - 10/2001



ALUMINIUM / PLASTIC
AUTOMATIC

Core Height	528mm	Core Width	590mm
Core Thickness	25mm 1 Row	Inlet / Outlet	39 / 39
Oil Cooler	305mm		
Condenser	CNX763	Receiver Drier	RDX755

Notes:

FOR1971

To suit Ford F250, F350
6 cyl 4.2L V8 5.4 & 7.3L 7/2001 - 10/2006



ALUMINIUM / PLASTIC
AUTOMATIC

Core Height	670mm	Core Width	745mm
Core Thickness	58mm 2 Row	Inlet / Outlet	45 / 45
Oil Cooler	305mm		
Condenser	CNX768	Receiver Drier	RDX755

Notes:

FOR43300

To suit Ford Falcon FG XR8
V8 5.4L 4/2008 >



ALUMINIUM / PLASTIC
AUTOMATIC

Core Height	650mm	Core Width	430mm
Core Thickness	32mm 1 Row	Inlet / Outlet	40 / 38
Oil Cooler	300mm		
Condenser	CNX4260	Receiver Drier	RDX0360

Notes: Stainless Steel Plate Cooler

M49CA

To suit Ford Falcon FG XR8
V8 5.4L 4/2008 >



ALUMINIUM / PLASTIC
AUTOMATIC

Core Height	650mm	Core Width	430mm
Core Thickness	27mm 1 Row	Inlet / Outlet	40 / 38
Oil Cooler	300mm		
Condenser	CNX4260	Receiver Drier	RDX0360

Notes:

M47CA

To suit Ford Falcon FG XR6 Barra
6 cyl 4.0L 4/2008 >



ALUMINIUM / PLASTIC
AUTOMATIC & MANUAL

Core Height	650mm	Core Width	430mm
Core Thickness	16mm 1 Row	Inlet / Outlet	38 / 40
Oil Cooler	N/A		
Condenser	CNX4260	Receiver Drier	RDX0360

Notes:

FOR43299

To suit Ford Falcon FG XR6 Barra
6 cyl 4.0L 4/2008 >



ALUMINIUM / PLASTIC
AUTOMATIC & MANUAL

Core Height	650mm	Core Width	430mm
Core Thickness	24mm 1 Row	Inlet / Outlet	38 / 40
Oil Cooler	N/A		
Condenser	CNX4260	Receiver Drier	RDX0360

Notes: External Oil Cooler

M48CM

To suit Ford Falcon FG
6 cyl 4.0L & V8 5.4L inc Turbo 4/2008 >



ALUMINIUM / PLASTIC
AUTOMATIC & MANUAL

Core Height	650mm	Core Width	430mm
Core Thickness	27mm 1 Row	Inlet / Outlet	40 / 38
Oil Cooler	N/A		
Condenser	CNX4260	Receiver Drier	RDX0360

Notes: External Oil Cooler

FOR43298

To suit Ford Falcon BF S1 & II XR6 XR8 Barra
V8 5.4L 9/2005 - 4/2009



ALUMINIUM / PLASTIC
AUTOMATIC

Core Height	650mm	Core Width	430mm
Core Thickness	32mm 1 Row	Inlet / Outlet	35 / 38 / 26
Oil Cooler	300mm		
Condenser	CNX6770	Receiver Drier	RDX759

Notes: Stainless Steel Plate Cooler

M46CA

To suit Ford Falcon BF XR8
V8 5.4L 9/2002 - 4/2009



ALUMINIUM / PLASTIC
AUTOMATIC

Core Height	650mm	Core Width	430mm
Core Thickness	27mm 1 Row	Inlet / Outlet	35 / 38 / 26
Oil Cooler	300mm		
Condenser	CNX6770	Receiver Drier	RDX759

Notes: Push on Transmission Line

FOR00610

To suit Ford Falcon BA SI & II Barra XR6, XR8
6 cyl & V8 9/2002 - 10/2005

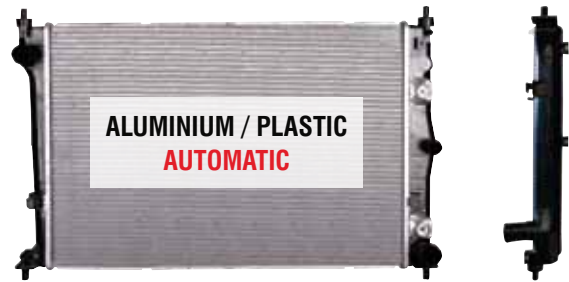

ALUMINIUM / PLASTIC
AUTOMATIC

Core Height	650mm	Core Width	440mm
Core Thickness	26mm 1 Row	Inlet / Outlet	37 / 40
Oil Cooler	250mm		
Condenser	CNX6770	Receiver Drier	RDX759

Notes: Stainless Steel Plate Cooler

FOR09591

To suit Ford Falcon BA SI & II Barra XR6, XR8
6 cyl & V8 9/2002 - 10/2005



ALUMINIUM / PLASTIC
MANUAL

Core Height	650mm	Core Width	440MM
Core Thickness	26mm 1 Row	Inlet / Outlet	35 / 38
Oil Cooler	N/A		
Condenser	CNX6770	Receiver Drier	RDX759

Notes:

FOR43290

To suit Ford Falcon BA SI & II Barra XR6, XR8
6 cyl & V8 9/2002 - 10/2005



ALUMINIUM / PLASTIC
AUTOMATIC

Core Height	650mm	Core Width	425mm
Core Thickness	24mm 1 Row	Inlet / Outlet	35 / 38
Oil Cooler	250mm		
Condenser	CNX6770	Receiver Drier	RDX759

Notes: Stainless Steel Plate Cooler

FOR43292

To suit Ford Falcon BA - BF SI & II
XR6, XR8 Barra
6 cyl & V8 9/2002 - 4/2009



ALUMINIUM / PLASTIC
AUTOMATIC & MANUAL

Core Height	650mm	Core Width	425mm
Core Thickness	24mm 1 Row	Inlet / Outlet	35 / 38
Oil Cooler	N/A		
Condenser	CNX6770	Receiver Drier	RDX759

Notes: Suits BA M/T & BF A/T [External Cooler]

FOR43297

To suit Ford Falcon BA - BF SI & II
XR6, XR8 Barra
6 cyl & V8 9/2002 - 4/2009



ALUMINIUM / PLASTIC
MANUAL

Core Height	650mm	Core Width	430mm
Core Thickness	32mm 1 Row	Inlet / Outlet	35 / 38
Oil Cooler	N/A		
Condenser	CNX6770	Receiver Drier	RDX759

Notes:

15-FOR43295

revolution

To suit Ford Falcon BA - BF SI & II
XR6, XR8 Barra
6 cyl & V8 9/2002 - 4/2009



Core Height	650mm	Core Width	425mm
Core Thickness	32mm 1 Row	Inlet / Outlet	35 / 38
Oil Cooler	250mm		
Condenser	CNX6770	Receiver Drier	RDX759

Notes: Stainless Steel Cooler

FOR43295

OEX

To suit Ford Falcon BA - BF SI & II
XR6, XR8 Barra
6 cyl & V8 9/2002 - 4/2009



Core Height	650mm	Core Width	425mm
Core Thickness	32mm 1 Row	Inlet / Outlet	35 / 38
Oil Cooler	250mm		
Condenser	CNX6770	Receiver Drier	RDX759

Notes: Stainless Steel Plate Cooler

M45CA

DENSO

To suit Ford Falcon BA - BF XR8
6 cyl 4.0L 9/2002 - 4/2009



Core Height	650mm	Core Width	430mm
Core Thickness	16mm 1 Row	Inlet / Outlet	37 / 40
Oil Cooler	250mm		
Condenser	CNX6770	Receiver Drier	RDX759

Notes:

M45CM

DENSO

To suit Ford Falcon BA - BF XR8
6 cyl 4.0L 9/2002 - 4/2009



Core Height	650mm	Core Width	430mm
Core Thickness	16mm 1 Row	Inlet / Outlet	37 / 40
Oil Cooler	N/A		
Condenser	CNX6770	Receiver Drier	RDX759

Notes:

M44CA

DENSO

To suit Ford Falcon BA - BF XR8
V8 5.4L 9/2002 - 4/2009



Core Height	650mm	Core Width	430mm
Core Thickness	27mm 1 Row	Inlet / Outlet	37 / 40
Oil Cooler	255mm		
Condenser	CNX6770	Receiver Drier	RDX759

Notes:

M44CM

DENSO

To suit Ford Falcon BA - BF XR8
V8 5.4L 9/2002 - 4/2009



Core Height	650mm	Core Width	430mm
Core Thickness	27mm 1 Row	Inlet / Outlet	37 / 40
Oil Cooler	N/A		
Condenser	CNX6770	Receiver Drier	RDX759

Notes:

15-FOR43280

revolution

To suit Ford Falcon AU SII & III XR6, XR8
6 cyl & V8 4/2000 - 3/2003



Core Height	660mm	Core Width	425mm
Core Thickness	34mm 1 Row	Inlet / Outlet	35 / 35
Oil Cooler	305mm		
Condenser	CNX009	Receiver Drier	RDX093

Notes: Stainless Steel Cooler

FOR43280

OEX

To suit Ford Falcon AU SII & III XR6, XR8
6 cyl & V8 4/2000 - 3/2003



Core Height	660mm	Core Width	425mm
Core Thickness	34mm 1 Row	Inlet / Outlet	35 / 35
Oil Cooler	305mm		
Condenser	CNX009	Receiver Drier	RDX093

Notes: Stainless Steel Plate Cooler

FOR43281

OEX

To suit Ford Falcon AU SII & III XR6, XR8
6 cyl & V8 4/2000 - 3/2003



Core Height	665mm	Core Width	425mm
Core Thickness	32mm 1 Row	Inlet / Outlet	35 / 35
Oil Cooler	305mm		
Condenser	CNX009	Receiver Drier	RDX093

Notes:

FOR43283

OEX

To suit Ford Falcon AU SI XR6, XR8
6 cyl & V8 9/1998 - 12/2000

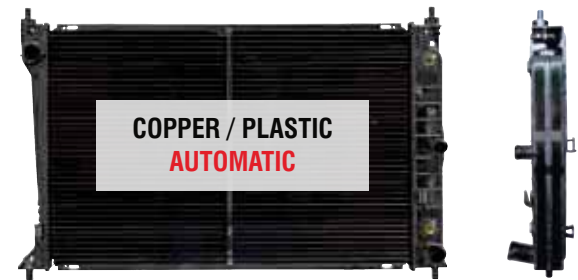

Core Height	665mm	Core Width	425mm
Core Thickness	28mm 2 Row	Inlet / Outlet	36 / 38
Oil Cooler	305mm		
Condenser	CNX009	Receiver Drier	RDX093

Notes:

15-FOR43260

revolution

To suit Ford Falcon EF - EL
XH I & II XR6, XR8
6 cyl & V8 8/1994 - 1/2000



Core Height	700mm	Core Width	420mm
Core Thickness	32mm 1 Row	Inlet / Outlet	36 / 38
Oil Cooler	225mm		
Condenser	CNX003	Receiver Drier	RDX085

Notes: 18 Fins Per Inch

FOR43260

OEX

To suit Ford Falcon EF - EL
XH I & II XR6, XR8
6 cyl & V8 8/1994 - 1/2000



Core Height	700mm	Core Width	420mm
Core Thickness	32mm 1 Row	Inlet / Outlet	36 / 38
Oil Cooler	225mm		
Condenser	CNX003	Receiver Drier	RDX085

Notes: 18 Fins Per Inch

FOR43258

To suit Ford Falcon EF - EL
XH I & II XR6, XR8
6 cyl & V8 8/1994 - 1/2000

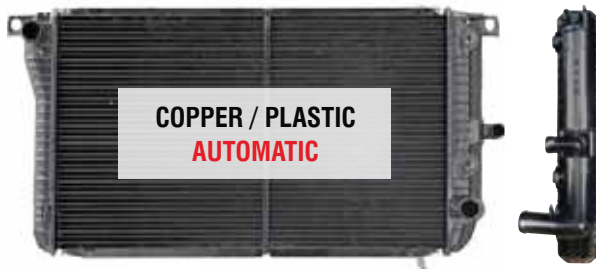

COPPER / PLASTIC
AUTOMATIC

Core Height	700mm	Core Width	420mm
Core Thickness	28mm 2 Row	Inlet / Outlet	38 / 38
Oil Cooler	225mm		
Condenser	CNX003	Receiver Drier	RDX085

Notes:

FD9340CA2

To suit Ford Falcon EF - EL XH XR6, XR8
6 cyl & V8 8/1994 - 1/2000

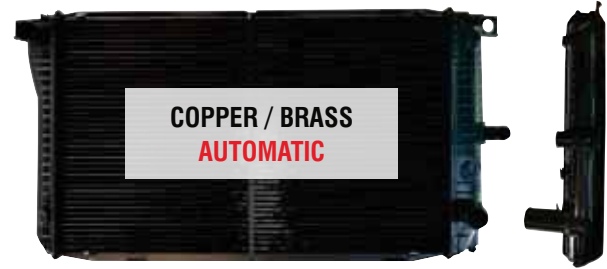

COPPER / BRASS
AUTOMATIC

Core Height	700mm	Core Width	420mm
Core Thickness	38mm 3 Rows	Inlet / Outlet	39 / 38
Oil Cooler	225mm		
Condenser	CNX003	Receiver Drier	RDX085

Notes:

15-FOR43234

To suit Ford Falcon EA - ED
6 cyl & V8 2/1988 - 8/1994



ALUMINIUM / PLASTIC
AUTOMATIC

Core Height	700mm	Core Width	420mm
Core Thickness	32mm 1 Row	Inlet / Outlet	38 / 45
Oil Cooler	225mm		
Condenser	CNX001	Receiver Drier	RDX084

Notes: 18 Fins Per Inch

FOR43234

To suit Ford Falcon EA - ED
6 cyl & V8 2/1988 - 8/1994



ALUMINIUM / PLASTIC
AUTOMATIC

Core Height	700mm	Core Width	420mm
Core Thickness	32mm 1 Row	Inlet / Outlet	38 / 45
Oil Cooler	225mm		
Condenser	CNX001	Receiver Drier	RDX084

Notes: 18 Fins Per Inch

FOR43232

To suit Ford Falcon EA - ED XR6 XR8
6 cyl & V8 2/1988 - 8/1994



COPPER / PLASTIC
AUTOMATIC

Core Height	700mm	Core Width	420mm
Core Thickness	28mm 2 Row	Inlet / Outlet	38 / 45
Oil Cooler	225mm		
Condenser	CNX001	Receiver Drier	RDX084

Notes: 8.5mm Tube Pitch

FD9340CA

To suit Ford Falcon EA - ED XR6 XR8
6 cyl & V8 2/1988 - 8/1994



COPPER / PLASTIC
AUTOMATIC

Core Height	700mm	Core Width	418mm
Core Thickness	38mm 3 Rows	Inlet / Outlet	38 / 45
Oil Cooler	225mm		
Condenser	CNX001	Receiver Drier	RDX084

Notes:

FOR1207

To suit Ford Falcon XG XR6 Longreach Ute
6 cyl 4.0L 3/1993 - 4/1997



Core Height	635mm	Core Width	415mm
Core Thickness	33mm 2 Row	Inlet / Outlet	38 / 38
Oil Cooler	225mm		
Condenser	CNX005	Receiver Drier	RDX083

Notes:

FD9288CA

To suit Ford Falcon XC - XF
6 cyl & V8 8/1976 - 1/1992



Core Height	658mm	Core Width	448mm
Core Thickness	38mm 3 Rows	Inlet / Outlet	38 / 45
Oil Cooler	225mm		
Condenser		Receiver Drier	RDX090

Notes:

M35CA

To suit Ford Festiva WB - WF
4 cyl 1.3 & 1.5L 3/1994 - 12/2000



Core Height	350mm	Core Width	641mm
Core Thickness	16mm 1 Row	Inlet / Outlet	29 / 33
Oil Cooler	275mm		
Condenser	CNX010	Receiver Drier	RDX283

Notes:

M34CM

To suit Ford Festiva WB - WF
4 cyl 1.3 & 1.5L 3/1994 - 12/2000



Core Height	350mm	Core Width	526mm
Core Thickness	16mm 1 Row	Inlet / Outlet	29 / 33
Oil Cooler	N/A		
Condenser	CNX010	Receiver Drier	RDX283

Notes:

G8CA

To suit Ford Festiva WB - WF
4 cyl 1.3 & 1.5L 3/1994 - 12/2000



Core Height	349mm	Core Width	380mm
Core Thickness	27mm 1 Row	Inlet / Outlet	28 / 28
Oil Cooler	275mm		
Condenser	CNX010	Receiver Drier	RDX283

Notes:

G8CM

To suit Ford Festiva WB - WF
4 cyl 1.3 & 1.5L 3/1994 - 12/2000



Core Height	350mm	Core Width	383mm
Core Thickness	27mm 2 Row	Inlet / Outlet	29 / 29
Oil Cooler	N/A		
Condenser	CNX010	Receiver Drier	RDX283

Notes:

G10CA

To suit Ford Festiva WB - WF
4 cyl 1.3 & 1.5L 3/1994 -12/2000



Core Height	350mm	Core Width	380mm
Core Thickness	26mm 1 Row	Inlet / Outlet	29 / 29
Oil Cooler	275mm		
Condenser	CNX010	Receiver Drier	RDX283

Notes:

G10CM

To suit Ford Festiva WB - WF
4 cyl 1.3 & 1.5L 3/1994 -12/2000



Core Height	350mm	Core Width	380mm
Core Thickness	26mm 1 Row	Inlet / Outlet	29 / 29
Oil Cooler	N/A		
Condenser	CNX010	Receiver Drier	RDX283

Notes:

M36CA

To suit Ford Festiva WA - WB SII
4 cyl 1.3 & 1.5L 10/1991 - 12/1997



Core Height	320mm	Core Width	382mm
Core Thickness	25mm 1 Row	Inlet / Outlet	29 / 29
Oil Cooler	200mm		
Condenser	CNX024	Receiver Drier	RDX600

Notes:

M36CM

To suit Ford Festiva WA - WB SII
4 cyl 1.3 & 1.5L 10/1991 - 12/1997



Core Height	320mm	Core Width	382mm
Core Thickness	16mm 1 Row	Inlet / Outlet	29 / 29
Oil Cooler	N/A		
Condenser	CNX024	Receiver Drier	RDX600

Notes:

FOR54761

To suit Ford Fiesta WS - WT
4 cyl 1.6L 1/2009 >



Core Height	560mm	Core Width	355mm
Core Thickness	16mm 1 row	Inlet / Outlet	28 / 28
Oil Cooler	N/A		
Condenser	CNX742	Receiver Drier	RDX0050

Notes:

FOR1879

To suit Ford Fiesta WP - WT XR4
4 cyl 1.4 1.6 & 2.0L 2/2004 >



Core Height	500mm	Core Width	340mm
Core Thickness	16mm 1 Row	Inlet / Outlet	33 / 33
Oil Cooler	N/A		
Condenser	CNX753	Receiver Drier	RDX188

Notes:

FOR64311

To suit Ford Fiesta WP - WQ
4 cyl 1.6L 2/2004 - 1/2006



ALUMINIUM / PLASTIC
MANUAL

Core Height	500mm	Core Width	342mm
Core Thickness	16mm 1 Row	Inlet / Outlet	33 / 33
Oil Cooler	N/A		
Condenser	CNX753	Receiver Drier	RDX188

Notes:

FOR40080

To suit Ford Focus LS LT XR5
5 cyl 2.5L Turbo 5/2006 - 6/2009



ALUMINIUM / PLASTIC
MANUAL

Core Height	670mm	Core Width	370mm
Core Thickness	24mm 1 Row	Inlet / Outlet	33 / 33
Oil Cooler	N/A		
Condenser	CNX774	Receiver Drier	RDX751

Notes:

FOR64031

To suit Ford Focus LR - LS XR5
4 cyl 1.8 & 2.0L inc Turbo 9/2002 - 7/2007



ALUMINIUM / PLASTIC
AUTOMATIC

Core Height	600mm	Core Width	367mm
Core Thickness	26mm 1 Row	Inlet / Outlet	33 / 33
Oil Cooler	N/A		
Condenser	CNX762	Receiver Drier	RDX185

Notes:

FOR20301

To suit Ford Focus LR
4 cyl 1.8 & 2.0L 9/2002 - 6/2005



ALUMINIUM / PLASTIC
AUTOMATIC & MANUAL

Core Height	600mm	Core Width	365mm
Core Thickness	26mm 1 Row	Inlet / Outlet	34 / 34
Oil Cooler	N/A		
Condenser	CNX762	Receiver Drier	RDX185

Notes:

M41CM

To suit Ford Laser KN - KQ
4 cyl 1.6 1.8 & 2.0L 2/1999 - 10/2002



ALUMINIUM / PLASTIC
MANUAL

Core Height	325mm	Core Width	680mm
Core Thickness	16mm 1 Row	Inlet / Outlet	29 / 29
Oil Cooler	N/A		
Condenser	CNX759	Receiver Drier	RDX182

Notes:

MAZ40142

To suit Ford Laser KN - KQ
4 cyl 1.6 & 1.8L 2/1999 - 10/2002



ALUMINIUM / PLASTIC
AUTOMATIC

Core Height	330mm	Core Width	688mm
Core Thickness	16mm 1 Row	Inlet / Outlet	28 / 28
Oil Cooler	350mm		
Condenser	CNX759	Receiver Drier	RDX182

Notes:

M33CM

To suit Ford Laser KJ SI II & III
4 cyl 1.6 & 1.8L 10/1994 - 2/1999



ALUMINIUM / PLASTIC
MANUAL

Core Height	325mm	Core Width	680mm
Core Thickness	16mm 1 Row	Inlet / Outlet	29 / 29
Oil Cooler	N/A		
Condenser	CNX011	Receiver Drier	RDX612

Notes:

FOR40065

To suit Ford Laser KJ - KQ
4 cyl 1.6 1.8 & 2.0L 10/1994 - 11/2002



ALUMINIUM / PLASTIC
AUTOMATIC

Core Height	330mm	Core Width	690mm
Core Thickness	24mm 1 Row	Inlet / Outlet	28 / 28
Oil Cooler	350mm		
Condenser	CNX011	Receiver Drier	RDX612

Notes: Multi-Fit

FOR40067

To suit Ford Laser KJ - KQ
4 cyl 1.6 1.8 & 2.0L 10/1994 - 10/2002



ALUMINIUM / PLASTIC
MANUAL

Core Height	330mm	Core Width	690mm
Core Thickness	24mm 1 Row	Inlet / Outlet	28 / 28
Oil Cooler	N/A		
Condenser	CNX011	Receiver Drier	RDX612

Notes: Multi-Fit

MAZ40144

To suit Ford Laser KJ - KQ
4 cyl 1.6 1.8 & 2.0L 10/1994 - 10/2002



ALUMINIUM / PLASTIC
MANUAL

Core Height	330mm	Core Width	688mm
Core Thickness	16mm 1 Row	Inlet / Outlet	28 / 28
Oil Cooler	N/A		
Condenser	CNX011	Receiver Drier	RDX612

Notes:

FOR40120

To suit Ford Laser KJ - KQ
4 cyl 1.6 1.8 & 2.0L 10/1994 - 10/2002

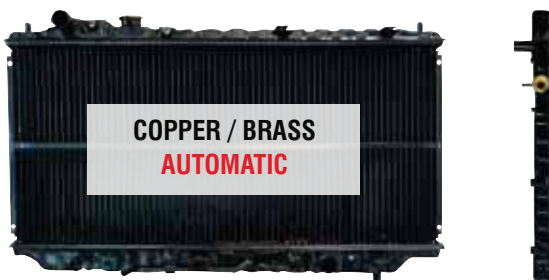

COPPER / BRASS
AUTOMATIC

Core Height	325mm	Core Width	692mm
Core Thickness	32mm 2 Row	Inlet / Outlet	29 / 29
Oil Cooler	350mm		
Condenser	CNX011	Receiver Drier	RDX612

Notes:

FOR40057

To suit Ford Laser KF - KH TX3
4 cyl 1.8L 4/1990 - 10/1994



ALUMINIUM / PLASTIC
MANUAL

Core Height	390mm	Core Width	648mm
Core Thickness	24mm 1 Row	Inlet / Outlet	32 / 32
Oil Cooler	N/A		
Condenser	CNX007	Receiver Drier	RDX180

Notes:

FOR40055

To suit Ford Laser KF - KH
4 cyl 1.6L 4/1990 - 10/1994



ALUMINIUM / PLASTIC
MANUAL



Core Height	390mm	Core Width	570mm
Core Thickness	16mm 1 Row	Inlet / Outlet	32 / 32
Oil Cooler	N/A		
Condenser	CNX007	Receiver Drier	RDX180

Notes:

MAZ40050

To suit Ford Laser KF - KH
4 cyl 1.6 & 1.8L 4/1990 - 10/1994



COPPER / BRASS
AUTOMATIC



Core Height	390mm	Core Width	640mm
Core Thickness	32mm 2 Row	Inlet / Outlet	33 / 33
Oil Cooler	275mm		
Condenser	CNX007	Receiver Drier	RDX180

Notes:

FOR40059

To suit Ford Laser KF - KH
4 cyl 1.6 & 1.8L 4/1990 - 10/1994



ALUMINIUM / PLASTIC
AUTOMATIC



Core Height	390mm	Core Width	648mm
Core Thickness	24mm 1 Row	Inlet / Outlet	31 / 31
Oil Cooler	270mm		
Condenser	CNX007	Receiver Drier	RDX180

Notes:

FOR40051

To suit Ford Laser KE I & II TX3
4 cyl 1.6L inc Turbo 10/1987 - 1/1996



ALUMINIUM / PLASTIC
MANUAL



Core Height	348mm	Core Width	570mm
Core Thickness	24mm 1 Row	Inlet / Outlet	35 / 35
Oil Cooler	N/A		
Condenser	CNX006	Receiver Drier	RDX086

Notes:

FOR40053

To suit Ford Laser KE I & II
4 cyl 1.6L 10/1987 - 1/1996



ALUMINIUM / PLASTIC
AUTOMATIC



Core Height	348mm	Core Width	570mm
Core Thickness	24mm 1 Row	Inlet / Outlet	35 / 35
Oil Cooler	200mm		
Condenser	CNX006	Receiver Drier	RDX086

Notes:

M13CM

To suit Ford Laser KC
4 cyl 1.6L 10/1985 - 10/1987



COPPER / PLASTIC
MANUAL



Core Height	350mm	Core Width	528mm
Core Thickness	16mm 1 Row	Inlet / Outlet	36 / 36
Oil Cooler	N/A		
Condenser	CNX006	Receiver Drier	RDX086

Notes:

M14CA

To suit Ford Laser KC
4 cyl 1.6L 10/1985 - 10/1987



COPPER / PLASTIC
AUTOMATIC

Core Height	350mm	Core Width	448mm
Core Thickness	32mm 2 Row	Inlet / Outlet	36 / 36
Oil Cooler	225mm		
Condenser	CNX006	Receiver Drier	RDX086

Notes:

FOR40100

To suit Ford Laser KC - KE
4 cyl 1.3L 10/1985 - 2/1990



COPPER / BRASS
MANUAL

Core Height	300mm	Core Width	448mm
Core Thickness	32mm 2 Row	Inlet / Outlet	36 / 36
Oil Cooler	N/A		
Condenser	CNX006	Receiver Drier	RDX086

Notes:

MAZ40051

To suit Ford Laser KA - KB
4 cyl 1.3 & 1.5L 3/1981 - 1/1986



COPPER / BRASS
MANUAL

Core Height	300mm	Core Width	590mm
Core Thickness	32mm 2 Row	Inlet / Outlet	36 / 36
Oil Cooler	N/A		
Condenser		Receiver Drier	RDX086

Notes:

FOR40120

To suit Ford Laser Lynx
4 cyl 1.6L 1/1992 - 12/1997 (NZ)

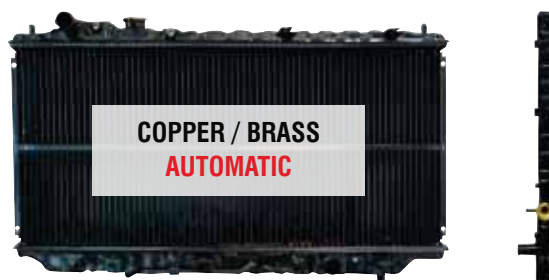

COPPER / BRASS
AUTOMATIC

Core Height	325mm	Core Width	692mm
Core Thickness	32mm 2 Row	Inlet / Outlet	29 / 29
Oil Cooler	350mm		
Condenser	CNX011	Receiver Drier	RDX612

Notes:

NIS41007

To suit Ford Maverick DA TB42
6 cyl 4.2L Diesel inc Turbo 2/1988 - 12/1997



COPPER / BRASS
MANUAL

Core Height	738mm	Core Width	455mm
Core Thickness	35mm 2 Row	Inlet / Outlet	41 / 41
Oil Cooler	N/A	Receiver Drier	RDX089 (Imperial)
Condenser	CNX022 / CNX535	Receiver Drier	RDX605 (PF)

Notes: CNX022 (Imperial Fittings) CNX535 (Y60 PF Condenser)

NIS41005

To suit Ford Maverick DA TB42
6 cyl 4.2L Petrol 2/1988 - 12/1997

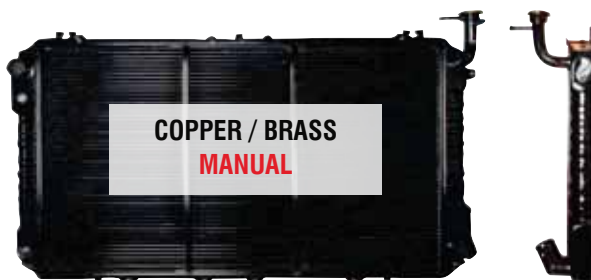

COPPER / BRASS
MANUAL

Core Height	738mm	Core Width	455mm
Core Thickness	35mm 2 Row	Inlet / Outlet	36 / 41
Oil Cooler	N/A	Receiver Drier	RDX089 (Imperial)
Condenser	CNX022 / CNX535	Receiver Drier	RDX605 (PF)

Notes: CNX022 (Imperial Fittings) CNX535 (Y60 PF Condenser)

M13CM

To suit Ford Meteor GC
4 cyl 1.6L 10/1985 - 9/1987



COPPER / PLASTIC
MANUAL

Core Height	350mm	Core Width	528mm
Core Thickness	16mm 1 Row	Inlet / Outlet	36 / 36
Oil Cooler	N/A		
Condenser	CNX006	Receiver Drier	RDX086

Notes:

M14CA

To suit Ford Meteor GC
4 cyl 1.6L 10/1985 - 9/1987



COPPER / PLASTIC
AUTOMATIC

Core Height	350mm	Core Width	448mm
Core Thickness	32mm 2 Row	Inlet / Outlet	36 / 36
Oil Cooler	225mm		
Condenser	CNX006	Receiver Drier	RDX086

Notes:

MAZ40051

To suit Ford Meteor GA - GB
4 cyl 1.5L 4/1982 - 10/1985



COPPER / BRASS
MANUAL

Core Height	300mm	Core Width	590mm
Core Thickness	32mm 2 Row	Inlet / Outlet	36 / 36
Oil Cooler	N/A		
Condenser		Receiver Drier	RDX086 / RDX022

Notes:

FOR1811

To suit Ford Mondeo HA - HE
4 cyl 2.0L 1/1995 - 4/2001



ALUMINIUM / PLASTIC
AUTOMATIC

Core Height	620mm	Core Width	385mm
Core Thickness	26mm 1 Row	Inlet / Outlet	26 / 26
Oil Cooler	250/250mm		
Condenser	CNX764	Receiver Drier	RDX756

Notes:

M42CA

To suit Ford Probe ST - SV
V6 2.5L 7/1994 - 8/1998



ALUMINIUM / PLASTIC
AUTOMATIC

Core Height	400mm	Core Width	640mm
Core Thickness	28mm 1 Row	Inlet / Outlet	37 / 37
Oil Cooler	300mm		
Condenser		Receiver Drier	

Notes:

FOR40318

To suit Ford Ranger PJ - PK
4 cyl 2.5 & 3.0L Turbo Diesel 11/2006 >



ALUMINIUM / PLASTIC
AUTOMATIC

Core Height	454mm	Core Width	648mm
Core Thickness	32mm 1 Row	Inlet / Outlet	35 / 35
Oil Cooler	375mm		
Condenser	CNX400 / CNX409	Receiver Drier	RDX0050 / RDX191

Notes: Multi-Fit

15-FOR40319

To suit Ford Ranger PJ - PK
4 cyl 2.5 & 3.0L Turbo Diesel 11/2006 >



ALUMINIUM / PLASTIC
MANUAL

Core Height	454mm	Core Width	648mm
Core Thickness	32mm 1 Row	Inlet / Outlet	35 / 35
Oil Cooler	N/A		
Condenser	CNX400 / CNX409	Receiver Drier	RDX0050 / RDX191

Notes: Multi-Fit

FOR40319

To suit Ford Ranger PJ - PK
4 cyl 2.5 & 3.0L Turbo Diesel 11/2006 >



ALUMINIUM / PLASTIC
MANUAL

Core Height	454mm	Core Width	648mm
Core Thickness	32mm 1 Row	Inlet / Outlet	35 / 35
Oil Cooler	N/A		
Condenser	CNX400 / CNX409	Receiver Drier	RDX0050 / RDX191

Notes: Multi-Fit

MAZ40130

To suit Ford Telstar AX, AY
V6 2.5L 12/1992 - 7/1996



COPPER / BRASS
AUTOMATIC

Core Height	688mm	Core Width	338mm
Core Thickness	32mm 2 Rows	Inlet / Outlet	36 / 36
Oil Cooler	225mm		
Condenser	CNX102 / CNX103	Receiver Drier	RDX182 / RDX087

Notes:

MAZ40135

To suit Ford Telstar AX, AY TX-5
V6 2.5L 1/1992 - 7/1996



ALUMINIUM / PLASTIC
AUTOMATIC

Core Height	690mm	Core Width	348mm
Core Thickness	24mm 1 Row	Inlet / Outlet	36 / 36
Oil Cooler	225mm		
Condenser	CNX102 / CNX103	Receiver Drier	RDX182 / RDX087

Notes:

MAZ40125

To suit Ford Telstar AX, AY TX-5
4 cyl 2.0L 1/1992 - 7/1996



ALUMINIUM / PLASTIC
AUTOMATIC

Core Height	688mm	Core Width	338mm
Core Thickness	32mm 2 Row	Inlet / Outlet	36 / 36
Oil Cooler	225mm		
Condenser	CNX102 / CNX103	Receiver Drier	RDX087 / RDX102

Notes:

M10CM

To suit Ford Telstar AR TX-5
4 cyl 2.0L 5/1983 - 9/1985



COPPER / BRASS
MANUAL

Core Height	350mm	Core Width	650mm
Core Thickness	16mm 1 Row	Inlet / Outlet	36 / 36
Oil Cooler	N/A		
Condenser		Receiver Drier	RDX086

Notes:

FOR43292

To suit Ford Territory SY SI & II Barra
6 cyl 4.0L 10/2005 >



ALUMINIUM / PLASTIC
AUTOMATIC & MANUAL

Core Height	650mm	Core Width	425mm
Core Thickness	24mm 1 Row	Inlet / Outlet	35 / 38
Oil Cooler	N/A		
Condenser	CNX6770	Receiver Drier	RDX759

Notes: Suits BA M/T & BF A/T [External Cooler]

FOR43297

To suit Ford Territory SY SI & II Barra
6 cyl 4.0L 10/2005 >



ALUMINIUM / PLASTIC
MANUAL

Core Height	650mm	Core Width	430mm
Core Thickness	32mm 1 Row	Inlet / Outlet	35 / 38
Oil Cooler	N/A		
Condenser	CNX6770	Receiver Drier	RDX759

Notes:

M45CA

To suit Ford Territory SX Barra
6 cyl 4.0L 4/2004 - 10/2005



ALUMINIUM / PLASTIC
AUTOMATIC

Core Height	650mm	Core Width	430mm
Core Thickness	16mm 1 Row	Inlet / Outlet	37 / 40
Oil Cooler	250mm		
Condenser	CNX6770	Receiver Drier	RDX759

Notes:

M45CM

To suit Ford Territory SX, SY
Barra 6 cyl 4.0L 4/2004 - 3/2010



ALUMINIUM / PLASTIC
MANUAL

Core Height	650mm	Core Width	430mm
Core Thickness	16mm 1 Row	Inlet / Outlet	37 / 40
Oil Cooler	N/A		
Condenser	CNX6770	Receiver Drier	RDX759

Notes:

15-FOR43295

To suit Ford Territory SX Barra
6 cyl 4.0L 4/2004 - 10/2005



ALUMINIUM / PLASTIC
AUTOMATIC

Core Height	650mm	Core Width	425mm
Core Thickness	32mm 1 Row	Inlet / Outlet	35 / 38
Oil Cooler	250mm		
Condenser	CNX6770	Receiver Drier	RDX759

Notes: Stainless Steel Cooler

FOR43295

To suit Ford Territory SX Barra
6 cyl 4.0L 4/2004 - 10/2005



ALUMINIUM / PLASTIC
AUTOMATIC

Core Height	650mm	Core Width	425mm
Core Thickness	32mm 1 Row	Inlet / Outlet	35 / 38
Oil Cooler	250mm		
Condenser	CNX6770	Receiver Drier	RDX759

Notes: Stainless Steel Plate Cooler

FOR00610

To suit Ford Territory SX Barra
6 cyl 4.0L 4/2004 - 10/2005



ALUMINIUM / PLASTIC
AUTOMATIC

Core Height	650mm	Core Width	440mm
Core Thickness	26mm 1 Row	Inlet / Outlet	37 / 40
Oil Cooler	250mm		
Condenser	CNX8300	Receiver Drier	RDX759

Notes: Stainless Steel Plate Oil Cooler

FOR09591

To suit Ford Territory SX Barra
6 cyl 4.0L 4/2004 - 10/2005



ALUMINIUM / PLASTIC
MANUAL

Core Height	650mm	Core Width	440MM
Core Thickness	26mm 1 Row	Inlet / Outlet	35 / 38
Oil Cooler	N/A		
Condenser	CNX6770	Receiver Drier	RDX759

Notes:

FOR55281

To suit Ford Transit VH
4 cyl 2.4L Turbo Diesel 12/2000 - 4/2005



ALUMINIUM / PLASTIC
MANUAL

Core Height	620mm	Core Width	400mm
Core Thickness	26mm 1 Row	Inlet / Outlet	32 / 32
Oil Cooler	N/A		
Condenser	CNX773	Receiver Drier	RDX751

Notes:

FOR64111

To suit Ford Transit VH - VJ
4 cyl 2.3L Petrol & 2.4L Turbo Diesel
12/2000 - 9/2006



ALUMINIUM / PLASTIC
AUTOMATIC & MANUAL

Core Height	770mm	Core Width	400mm
Core Thickness	26mm 1 Row	Inlet / Outlet	34 / 34
Oil Cooler	N/A		
Condenser		Receiver Drier	

Notes:

FOR20221

To suit Ford Transit VF - VG
4 cyl 2.5L Turbo Diesel 4/1996 - 12/2000



ALUMINIUM / PLASTIC
MANUAL

Core Height	600mm	Core Width	360mm
Core Thickness	42mm 2 Row	Inlet / Outlet	38 / 38
Oil Cooler	N/A		
Condenser	CNX755	Receiver Drier	RDX750

Notes:

FOR15471

To suit Ford Transit VF - VG
4 cyl 2.5L Turbo Diesel 4/1996 - 12/2000



ALUMINIUM / PLASTIC
MANUAL

Core Height	600mm	Core Width	360mm
Core Thickness	38mm 1 Row	Inlet / Outlet	38 / 38
Oil Cooler	N/A		
Condenser	CNX755	Receiver Drier	RDX750

Notes:

FOR2219

To suit Ford Transit VE
4 cyl 2.5L Diesel 12/1994 - 4/1997



Core Height	700mm	Core Width	358mm
Core Thickness	28mm 1 Row	Inlet / Outlet	38 / 38
Oil Cooler	N/A		
Condenser		Receiver Drier	

Notes: 10mm Return Pipe Drivers Side

FRE53561

To suit Freightliner Argosy Evolution S60
6 cyl 430 - 620hp



Core Height	1195mm	Core Width	665mm
Core Thickness	52mm 1 Row	Inlet / Outlet	64 / 64
Oil Cooler	N/A		
Condenser	CNX775	Receiver Drier	RDX533

Notes:

FRE53251

To suit Freightliner Columbia CL112 C-12
6 cyl 12 & 12.8L inc Turbo



Core Height	1065mm	Core Width	798mm
Core Thickness	46mm 2 Row	Inlet / Outlet	64 / 64
Oil Cooler	N/A		
Condenser	CNX825	Receiver Drier	RDX542

Notes:

FRE61591

To suit Freightliner Century Class
2009 >



Core Height	915mm	Core Width	978mm
Core Thickness	52mm	Inlet / Outlet	64 / 64
Oil Cooler	N/A		
Condenser	CNX825	Receiver Drier	RDX542

Notes:

FRE53361

To suit Freightliner Century Class
CST120 C-15
6 cyl 600hp Diesel



Core Height	915mm	Core Width	800mm
Core Thickness	46mm 2 Row	Inlet / Outlet	64 / 64
Oil Cooler	N/A		
Condenser	CNX825	Receiver Drier	

Notes:

FRE53341

To suit Freightliner FL106



Core Height	865mm	Core Width	637mm
Core Thickness	46mm	Inlet / Outlet	58 / 50
Oil Cooler	N/A		
Condenser		Receiver Drier	

Notes:

FRE53351

To suit Freightliner FL112, FLD120
Diesel Truck



Core Height	915mm	Core Width	690mm
Core Thickness	51mm 2 Row	Inlet / Outlet	64 / 64
Oil Cooler	N/A		
Condenser	CNX770 / CNX771	Receiver Drier	RDX517

Notes:

FRE53471

To suit Freightliner FL80
6 cyl 14.6L



Core Height	730mm	Core Width	635mm
Core Thickness	48mm 2 Row	Inlet / Outlet	52 / 62
Oil Cooler	N/A		
Condenser		Receiver Drier	

Notes:

FRE53451

To suit Freightliner FLD Columbia



Core Height	940mm	Core Width	819mm
Core Thickness	56mm	Inlet / Outlet	76 / 76
Oil Cooler	N/A		
Condenser		Receiver Drier	

Notes:

HIN1123

To suit Hino Ranger FD1J, FG1J, FT1J,
GD1J, GH1J, J08CFT
6 cyl 8.0L Turbo Diesel 11/1993 - 1/2003



Core Height	720mm	Core Width	635mm
Core Thickness	36mm 1 Row	Inlet / Outlet	56 / 56
Oil Cooler	N/A		
Condenser		Receiver Drier	

Notes:

HIN1244

To suit Hino Ranger Pro Series
6 cyl 8.0L 2006 >



Core Height	720mm	Core Width	634mm
Core Thickness	36mm 1 Row	Inlet / Outlet	56 / 56
Oil Cooler	N/A		
Condenser		Receiver Drier	

Notes:

15-HOL24850

To suit Holden Adventra VZ
V6 3.6L 2/2005 - 1/2009



Core Height	675mm	Core Width	430mm
Core Thickness	32mm 1 Row	Inlet / Outlet	35 / 35
Oil Cooler	295mm		
Condenser	CNX231	Receiver Drier	RDX106

Notes: Stainless Steel Cooler

HOL24850

To suit Holden Adventra VZ
V6 3.6L 2/2005 - 1/2009



ALUMINIUM / PLASTIC
AUTOMATIC

Core Height	675mm	Core Width	430mm
Core Thickness	32mm 1 Row	Inlet / Outlet	35 / 35
Oil Cooler	295mm		
Condenser	CNX231	Receiver Drier	RDX106

Notes: Stainless Steel Plate Cooler

HOL3326C

To suit Holden Adventra VZ
V6 3.6L 2/2005 - 1/2009



ALUMINIUM / PLASTIC
AUTOMATIC

Core Height	675mm	Core Width	431mm
Core Thickness	27mm 1 Row	Inlet / Outlet	35 / 35
Oil Cooler	290mm		
Condenser	CNX231	Receiver Drier	RDX106

Notes:

HOL3325C

To suit Holden Adventra VZ Gen III
V8 5.7L 2/2005 - 1/2006



ALUMINIUM / PLASTIC
AUTOMATIC

Core Height	675mm	Core Width	430mm
Core Thickness	35mm 2 Row	Inlet / Outlet	35 / 35
Oil Cooler	290mm		
Condenser	CNX231	Receiver Drier	RDX106

Notes:

HOL24870

To suit Holden Adventra VZ Gen III
V8 5.7L 2/2005 - 1/2006



ALUMINIUM / PLASTIC
AUTOMATIC

Core Height	675mm	Core Width	430mm
Core Thickness	32mm 1 Row	Inlet / Outlet	35 / 35
Oil Cooler	290mm		
Condenser	CNX231	Receiver Drier	RDX106

Notes: Stainless Steel Plate Cooler

15-HOL24820

To suit Holden Adventra VY Gen III
V8 5.7L 9/2003 - 2/2005



ALUMINIUM / PLASTIC
AUTOMATIC

Core Height	675mm	Core Width	430mm
Core Thickness	32mm 1 Row	Inlet / Outlet	35 / 35
Oil Cooler	295mm		
Condenser	CNX228	Receiver Drier	RDX117

Notes: Stainless Steel Cooler

HOL24820

To suit Holden Adventra VY Gen III
V8 5.7L 9/2003 - 2/2005



ALUMINIUM / PLASTIC
AUTOMATIC

Core Height	675mm	Core Width	430mm
Core Thickness	32mm 1 Row	Inlet / Outlet	35 / 35
Oil Cooler	295mm		
Condenser	CNX228	Receiver Drier	RDX117

Notes: Stainless Steel Plate Cooler

TOY60232

To suit Holden Apollo JM JP
4 cyl V6 3.0L 2/1993 - 6/1997



COPPER / PLASTIC
AUTOMATIC

Core Height	425mm	Core Width	715mm
Core Thickness	32mm 2 Row	Inlet / Outlet	34 / 34
Oil Cooler	375mm		
Condenser	CNX055	Receiver Drier	RDX281

Notes:

15-TOY60230

To suit Holden Apollo JM JP
4 cyl 2.2L 2/1993 - 6/1997



ALUMINIUM / PLASTIC
AUTOMATIC

Core Height	425mm	Core Width	715mm
Core Thickness	32mm 2 Row	Inlet / Outlet	31 / 31
Oil Cooler	375mm		
Condenser	CNX055	Receiver Drier	RDX281

Notes:

TOY60230

To suit Holden Apollo JM JP
4 cyl 2.2L 2/1993 - 6/1997



COPPER / PLASTIC
AUTOMATIC

Core Height	425mm	Core Width	715mm
Core Thickness	32mm 2 Row	Inlet / Outlet	31 / 31
Oil Cooler	375mm		
Condenser	CNX055	Receiver Drier	RDX281

Notes:

TOY60228

To suit Holden Apollo JK JL
4 cyl 2.0L 8/1989 - 2/1993



COPPER / PLASTIC
MANUAL

Core Height	325mm	Core Width	665mm
Core Thickness	16mm 1 Row	Inlet / Outlet	31 / 31
Oil Cooler	N/A		
Condenser	CNX051	Receiver Drier	RDX161

Notes:

TOY60226

To suit Holden Apollo JK JL
4 cyl 2.0L 8/1989 - 2/1993

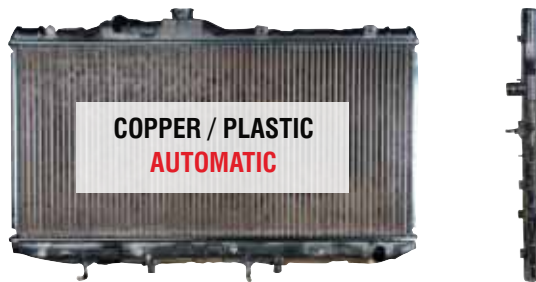

COPPER / PLASTIC
AUTOMATIC

Core Height	325mm	Core Width	665mm
Core Thickness	16mm 1 Row	Inlet / Outlet	31 / 31
Oil Cooler	275mm		
Condenser	CNX051	Receiver Drier	RDX161

Notes:

HOL12601

To suit Holden Astra AH
4 cyl 1.9L Turbo Diesel 5/2006 - 12/2009



ALUMINIUM / PLASTIC
MANUAL

Core Height	600mm	Core Width	368mm
Core Thickness	42mm 2 Row	Inlet / Outlet	34 / 34
Oil Cooler	N/A		
Condenser	CNX202	Receiver Drier	RDX0050

15-HOL10321

revolution

To suit Holden Astra AH
4 cyl 2.2L 1/2006 - 6/2009



Core Height	600mm	Core Width	375mm
Core Thickness	32mm 2 Row	Inlet / Outlet	34 / 34
Oil Cooler	N/A		
Condenser	CNX206 / CNX047	Receiver Drier	RDX119 / RDX114

Notes:

HOL10321

BEHR MELLER SERVICE

To suit Holden Astra AH
4 cyl 2.2L 1/2006 - 6/2009



Core Height	600mm	Core Width	375mm
Core Thickness	26mm 2 Row	Inlet / Outlet	34 / 34
Oil Cooler	250mm		
Condenser	CNX206 / CNX047	Receiver Drier	RDX119 / RDX114

Notes:

HOL10311

BEHR MELLER SERVICE

To suit Holden Astra AH
4 cyl 2.0L Turbo Diesel & 2.2L Petrol 1/2006 >



Core Height	600mm	Core Width	375mm
Core Thickness	26mm 2 Row	Inlet / Outlet	34 / 34
Oil Cooler	N/A		
Condenser	CNX206 / CNX047	Receiver Drier	RDX119 / RDX114

Notes:

HOL45771

BEHR MELLER SERVICE

To suit Holden Astra AH
4 cyl 1.8L 9/2004 - 12/2009



Core Height	600mm	Core Width	350mm
Core Thickness	16mm 1 Row	Inlet / Outlet	35 / 35
Oil Cooler	255mm		
Condenser	CNX204	Receiver Drier	RDX0050

Notes:

HOL54081

OEX

To suit Holden Astra AH
4 cyl 1.8L 9/2004 - 1/2010



Core Height	600mm	Core Width	365mm
Core Thickness	16mm 1 Row	Inlet / Outlet	35 / 35
Oil Cooler	N/A		
Condenser	CNX203	Receiver Drier	RDX0050

Notes:

HOL10331

BEHR MELLER SERVICE

To suit Holden Astra TS
4 cyl 2.2L 1/2001 - 12/2006



Core Height	600mm	Core Width	365mm
Core Thickness	34mm 1 Row	Inlet / Outlet	34 / 34
Oil Cooler	250mm		
Condenser	CNX206 / CNX047	Receiver Drier	RDX119 / RDX114

Notes:

HOL23015

To suit Holden Astra TS
4 cyl 1.8 & 2.2L 1/2001 - 4/2006



Core Height	600mm	Core Width	375mm
Core Thickness	32mm 1 Row	Inlet / Outlet	34 / 34
Oil Cooler	250mm		
Condenser	CNX206 / CNX047	Receiver Drier	RDX119 / RDX114

Notes:

15-HOL10321

To suit Holden Astra TS
4 cyl 1.8 & 2.2L 9/1998 - 12/2006



Core Height	600mm	Core Width	375mm
Core Thickness	26mm 2 Row	Inlet / Outlet	34 / 34
Oil Cooler	250mm		
Condenser	CNX206 / CNX047	Receiver Drier	RDX119 / RDX114

Notes:

HOL10321

To suit Holden Astra TS
4 cyl 1.8 & 2.2L 9/1998 - 12/2006



Core Height	600mm	Core Width	375mm
Core Thickness	26mm 2 Row	Inlet / Outlet	34 / 34
Oil Cooler	250mm		
Condenser	CNX206 / CNX047	Receiver Drier	RDX119 / RDX114

Notes:

HOL23012

To suit Holden Astra TR
4 cyl 1.6, 1.8 & 2.0L 9/1995 - 9/1998



Core Height	590mm	Core Width	360mm
Core Thickness	24mm 1 Row	Inlet / Outlet	35 / 35
Oil Cooler	N/A		
Condenser	CNX031	Receiver Drier	RDX107

Notes:

HOL23010

To suit Holden Astra TR
4 cyl 1.6, 1.8 & 2.0L 9/1995 - 9/1998



Core Height	590mm	Core Width	360mm
Core Thickness	24mm 1 Row	Inlet / Outlet	35 / 35
Oil Cooler	235mm		
Condenser	CNX031	Receiver Drier	RDX107

Notes:

NIS40025

To suit Holden Astra LC LD
4 cyl 1.6 & 1.8L 4/1986 - 1/1990



Core Height	588mm	Core Width	345mm
Core Thickness	24mm 1 Row	Inlet / Outlet	37 / 37
Oil Cooler	180mm		
Condenser	CNX526	Receiver Drier	RDX033

Notes:

NIS46150

To suit Holden Astra LC LD
4 cyl 1.6 & 1.8L 4/1986 - 1/1990

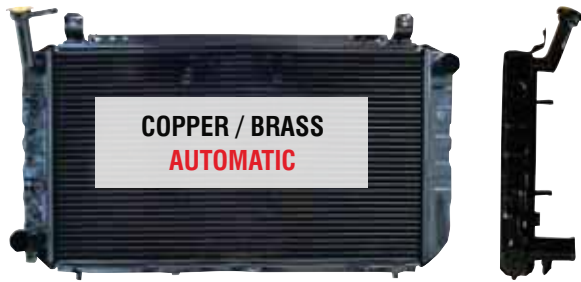

COPPER / BRASS
AUTOMATIC

Core Height	590mm	Core Width	345mm
Core Thickness	32mm 2 Row	Inlet / Outlet	36 / 36
Oil Cooler	180mm		
Condenser	CNX526	Receiver Drier	RDX033

Notes:

DAE1009

To suit Holden Barina TK
4 cyl 1.6L 10/2005 - 5/2009



ALUMINIUM / PLASTIC
MANUAL

Core Height	480mm	Core Width	410mm
Core Thickness	16mm 1 Row	Inlet / Outlet	34 / 34
Oil Cooler	N/A		
Condenser	CNX158	Receiver Drier	

Notes:

DAE0003

To suit Holden Barina TK
4 cyl 1.6L 10/2005 - 5/2009



ALUMINIUM / PLASTIC
AUTOMATIC

Core Height	600mm	Core Width	410mm
Core Thickness	16mm 1 Row	Inlet / Outlet	34 / 34
Oil Cooler	250mm		
Condenser	CNX158	Receiver Drier	

Notes:

HOL14371

To suit Holden Barina XC
4 cyl 1.4L 4/2001 - 10/2005



ALUMINIUM / PLASTIC
AUTOMATIC

Core Height	540mm	Core Width	350mm
Core Thickness	25mm 1 Row	Inlet / Outlet	34 / 34
Oil Cooler	250mm		
Condenser	CNX306	Receiver Drier	RDX134

Notes:

HOL14341

To suit Holden Barina XC
4 cyl 1.4 & 1.8L 4/2001 - 10/2005



ALUMINIUM / PLASTIC
MANUAL

Core Height	540mm	Core Width	375mm
Core Thickness	26mm 2 Row	Inlet / Outlet	35 / 35
Oil Cooler	N/A		
Condenser	CNX229	Receiver Drier	RDX110

Notes:

HOL14361

To suit Holden Barina XC
4 cyl 1.4 & 1.8L 4/2001 - 10/2005



ALUMINIUM / PLASTIC
MANUAL

Core Height	540mm	Core Width	375mm
Core Thickness	26mm 1 Row	Inlet / Outlet	34 / 34
Oil Cooler	N/A		
Condenser	CNX306	Receiver Drier	RDX134

Notes:

HOL12011

To suit Holden Barina SB
4 cyl 1.4L 1/1994 - 12/2000



ALUMINIUM / PLASTIC
AUTOMATIC & MANUAL

Core Height	530mm	Core Width	285mm
Core Thickness	26mm	Inlet / Outlet	29 / 29
Oil Cooler	N/A		
Condenser	CNX049	Receiver Drier	RDX108

Notes:

HOL12001

To suit Holden Barina SB
4 cyl 1.2 1.4 & 1.6L 1/1994 - 12/2000



ALUMINIUM / PLASTIC
MANUAL

Core Height	530mm	Core Width	285mm
Core Thickness	26mm 2 Row	Inlet / Outlet	34 / 34
Oil Cooler	N/A		
Condenser	CNX049	Receiver Drier	RDX108

Notes:

HOL25205

To suit Holden Barina MF MH SB
4 cyl 1.2 1.4 1.6L 1/1989 - 9/2002



COPPER / PLASTIC
AUTOMATIC

Core Height	680mm	Core Width	260mm
Core Thickness	30mm 2 Row	Inlet / Outlet	33 / 33
Oil Cooler	220mm		
Condenser	CNX309 / CNX049	Receiver Drier	RDX108 (SB)

Notes: Condenser options CNX309 (R12 only) / CNX049 (SB)

HOL25206

To suit Holden Barina MF MH SB
4 cyl 1.2 1.4 & 1.6L 1/1989 - 9/2002



COPPER / PLASTIC
MANUAL

Core Height	680mm	Core Width	260mm
Core Thickness	30mm 2 Row	Inlet / Outlet	33 / 33
Oil Cooler	N/A		
Condenser	CNX309 / CNX049	Receiver Drier	RDX108 (SB)

Notes: Condenser options CNX309 (R12only) / CNX049 (SB)

HOL25200

To suit Holden Barina SB
4 cyl 1.4L 1/1994 - 12/2000

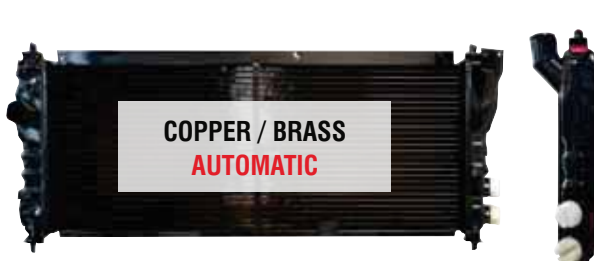

COPPER / BRASS
AUTOMATIC

Core Height	680mm	Core Width	270mm
Core Thickness	32mm 2 Rows	Inlet / Outlet	36 / 36
Oil Cooler	210mm		
Condenser	CNX049	Receiver Drier	RDX108

Notes:

SUZ58110

To suit Holden Barina MF - MH
4 cyl 1.3L 1/1989 - 4/1995



COPPER / PLASTIC
MANUAL

Core Height	325mm	Core Width	328mm
Core Thickness	32mm 2 Row	Inlet / Outlet	28 / 28
Oil Cooler	N/A	Receiver Drier	RDX160
Condenser	CNX309	Receiver Drier	RDX283

Notes:

HOL1260

To suit Holden Barina MB - ML
4 cyl 1.3L 2/1985 - 4/1995



COPPER / PLASTIC
MANUAL

Core Height	350mm	Core Width	360mm
Core Thickness	16mm 1 Row	Inlet / Outlet	29 / 29
Oil Cooler	N/A		
Condenser	CNX309	Receiver Drier	RDX086

Notes:

HOL1791

To suit Holden Barina MB - ML
4 cyl 1.3L 1991 - 1994



COPPER / PLASTIC
MANUAL

Core Height	325mm	Core Width	325mm
Core Thickness	32mm 2 Row	Inlet / Outlet	28 / 28
Oil Cooler	N/A		
Condenser		Receiver Drier	RDX086

Notes:

HOL2696

To suit Holden Colorado
4 cyl 3.0L Turbo Diesel 7/2008 >



ALUMINIUM / PLASTIC
AUTOMATIC

Core Height	475mm	Core Width	590mm
Core Thickness	28mm 1 Row	Inlet / Outlet	36 / 36
Oil Cooler	350mm		
Condenser	CNX237	Receiver Drier	RDX118

Notes: Condenser options CNX237

HOL2695

To suit Holden Colorado
4 cyl 3.0L Turbo Diesel 7/2008 >



ALUMINIUM / PLASTIC
MANUAL

Core Height	475mm	Core Width	590mm
Core Thickness	28mm 1 Row	Inlet / Outlet	38 / 38
Oil Cooler	N/A		
Condenser	CNX237	Receiver Drier	RDX118

Notes: Condenser options CNX237

HOL14341

To suit Holden Combo XC
4 cyl 1.4L 12/2004 - 10/2007



ALUMINIUM / PLASTIC
MANUAL

Core Height	540mm	Core Width	375mm
Core Thickness	26mm 2 Row	Inlet / Outlet	35 / 35
Oil Cooler	N/A		
Condenser	CNX229	Receiver Drier	RDX110

Notes:

HOL14361

To suit Holden Combo XC
4 cyl 1.6L 9/2002 - 1/2006



ALUMINIUM / PLASTIC
MANUAL

Core Height	540mm	Core Width	375mm
Core Thickness	26mm 1 Row	Inlet / Outlet	34 / 34
Oil Cooler	N/A		
Condenser	CNX306 / CNX229	Receiver Drier	RDX134 / RDX110

Notes:

HOL25209

To suit Holden Combo XC
4 cyl 1.6L 9/2002 - 1/2006



Core Height	540mm	Core Width	375mm
Core Thickness	24mm 1 Row	Inlet / Outlet	34 / 34
Oil Cooler	N/A		
Condenser	CNX229 / CNX306	Receiver Drier	RDX134 / RDX110

Notes:

HOL12001

To suit Holden Combo SB
4 cyl 1.4L 2/1996 - 8/1997



Core Height	530mm	Core Width	285mm
Core Thickness	26mm 2 Row	Inlet / Outlet	34 / 34
Oil Cooler	N/A		
Condenser	CNX049	Receiver Drier	RDX108

Notes:

HOL33431

To suit Holden Commodore VE SI & II
V6 3.0 & 3.6L 7/2006 >

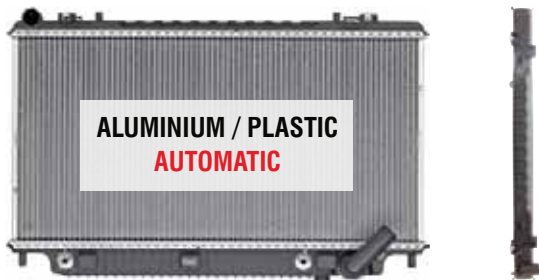

Core Height	385mm	Core Width	755mm
Core Thickness	24mm 1 Row	Inlet / Outlet	35 / 35
Oil Cooler	450mm		
Condenser	CNX235	Receiver Drier	RDX113

Notes: Stainless Steel Plate Cooler

HOL33451

To suit Holden Commodore VE SI & II
V6 3.0 & 3.6L 7/2006 >



Core Height	385mm	Core Width	755mm
Core Thickness	24mm 1 Row	Inlet / Outlet	35 / 35
Oil Cooler	N/A		
Condenser	CNX235	Receiver Drier	RDX113

Notes:

HOL24882

To suit Holden Commodore VE SI & II
V6 3.0 & 3.6L 7/2006 >

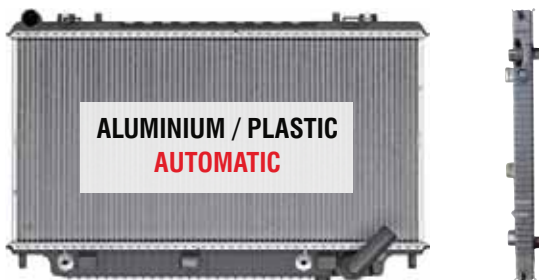

Core Height	385mm	Core Width	755mm
Core Thickness	26mm 1 Row	Inlet / Outlet	35 / 35
Oil Cooler	450mm		
Condenser	CNX235	Receiver Drier	RDX113

Notes:

HOL24883

To suit Holden Commodore VE SI & II
V6 3.0 & 3.6L 7/2006 >



Core Height	385mm	Core Width	755mm
Core Thickness	26mm 1 Row	Inlet / Outlet	35 / 35
Oil Cooler	N/A		
Condenser	CNX235	Receiver Drier	RDX113

Notes:

HOL24885

To suit Holden Commodore VE SI & II
V8 6.0L 7/2006 >



ALUMINIUM / PLASTIC
AUTOMATIC

Core Height	380mm	Core Width	755mm
Core Thickness	42mm 2 Row	Inlet / Outlet	35 / 35
Oil Cooler	450mm		
Condenser	CNX235	Receiver Drier	RDX113

Notes:

HOL24886

To suit Holden Commodore VE SI & II
V8 6.0L 7/2006 >



ALUMINIUM / PLASTIC
MANUAL

Core Height	385mm	Core Width	755mm
Core Thickness	42mm 2 Row	Inlet / Outlet	35 / 35
Oil Cooler	N/A		
Condenser	CNX235	Receiver Drier	RDX113

Notes:

HOL24850

To suit Holden Commodore VZ V6
3.6L 8/2004 - 4/2007



ALUMINIUM / PLASTIC
AUTOMATIC

Core Height	675mm	Core Width	430mm
Core Thickness	32mm 1 Row	Inlet / Outlet	35 / 35
Oil Cooler	295mm		
Condenser	CNX231	Receiver Drier	RDX106

Notes: Stainless Steel Plate Cooler

15-HOL24850

To suit Holden Commodore VZ V6
3.6L 8/2004 - 4/2007



ALUMINIUM / PLASTIC
AUTOMATIC

Core Height	675mm	Core Width	430mm
Core Thickness	32mm 1 Row	Inlet / Outlet	35 / 35
Oil Cooler	295mm		
Condenser	CNX231	Receiver Drier	RDX106

Notes: Stainless Steel Cooler

HOL24860

To suit Holden Commodore VZ V6
3.6L 8/2004 - 10/2007



ALUMINIUM / PLASTIC
MANUAL

Core Height	675mm	Core Width	430mm
Core Thickness	32mm 1 Row	Inlet / Outlet	35 / 35
Oil Cooler	N/A		
Condenser	CNX231	Receiver Drier	RDX106

Notes:

HOL3326C

To suit Holden Commodore VZ V6
3.6L 8/2004 - 10/2007



ALUMINIUM / PLASTIC
AUTOMATIC

Core Height	675mm	Core Width	431mm
Core Thickness	27mm 1 Row	Inlet / Outlet	35 / 35
Oil Cooler	290mm		
Condenser	CNX231	Receiver Drier	RDX106

Notes:

HOL3327C

To suit Holden Commodore VZ V6
3.6L 8/2004 - 10/2007



Core Height	675mm	Core Width	431mm
Core Thickness	27mm 1 Row	Inlet / Outlet	35 / 35
Oil Cooler	N/A		
Condenser	CNX231	Receiver Drier	RDX106

Notes:

HOL24870

To suit Holden Commodore VZ Gen III
V8 5.7 & 6.0L 8/2004 - 10/2007



Core Height	675mm	Core Width	430mm
Core Thickness	32mm 1 Row	Inlet / Outlet	35 / 35
Oil Cooler	290mm		
Condenser	CNX231	Receiver Drier	RDX106

Notes: Stainless Steel Plate Cooler

HOL24880

To suit Holden Commodore VZ Gen III
V8 5.7 & 6.0L 8/2004 - 10/2007



Core Height	675mm	Core Width	430mm
Core Thickness	32mm 1 Row	Inlet / Outlet	35 / 35
Oil Cooler	N/A		
Condenser	CNX231	Receiver Drier	RDX106

Notes:

HOL3325C

To suit Holden Commodore VZ Gen III
V8 5.7 & 6.0L 8/2004 - 10/2007



Core Height	675mm	Core Width	430mm
Core Thickness	35mm 2 Row	Inlet / Outlet	35 / 35
Oil Cooler	290mm		
Condenser	CNX231	Receiver Drier	RDX106

Notes:

HOL3328C

To suit Holden Commodore VZ Gen III
V8 5.7 & 6.0L 8/2004 - 10/2007



Core Height	675mm	Core Width	430mm
Core Thickness	35mm 1 Row	Inlet / Outlet	35 / 35
Oil Cooler	N/A		
Condenser	CNX231	Receiver Drier	RDX106

Notes:

HOL24800

To suit Holden Commodore VY SI & II
V6 3.8L inc Supercharged 9/2002 - 8/2004



Core Height	675mm	Core Width	430mm
Core Thickness	24mm 1 Row	Inlet / Outlet	35 / 35
Oil Cooler	295mm		
Condenser	CNX228	Receiver Drier	RDX117

Notes: Stainless Steel Plate Cooler

15-HOL24800

revolution

To suit Holden Commodore VY SI & II
V6 3.8L inc Supercharged 9/2002 - 8/2004



Core Height	675mm	Core Width	430mm
Core Thickness	24mm 1 Row	Inlet / Outlet	35 / 35
Oil Cooler	295mm		
Condenser	CNX228	Receiver Drier	RDX117

Notes: Stainless Steel Plate Cooler

HOL3320C

CALSONIC

To suit Holden Commodore VY SI & II
V6 3.8L inc Supercharged 9/2002 - 8/2004



Core Height	675mm	Core Width	430mm
Core Thickness	19mm 1 Row	Inlet / Outlet	35 / 35
Oil Cooler	290mm		
Condenser	CNX228	Receiver Drier	RDX117

Notes:

HOL81431

BEHR
HELL
SERVICE

To suit Holden Commodore VY SI & II
V6 3.8L inc Supercharged 9/2002 - 8/2004



Core Height	675mm	Core Width	446mm
Core Thickness	28mm	Inlet / Outlet	38 / 38
Oil Cooler	N/A		
Condenser	CNX228	Receiver Drier	RDX117

Notes:

HOL24810

OEX

To suit Holden Commodore VY SI & II
V6 3.8L 9/2002 - 8/2004



Core Height	675mm	Core Width	430mm
Core Thickness	24mm 1 Row	Inlet / Outlet	35 / 35
Oil Cooler	N/A		
Condenser	CNX228	Receiver Drier	RDX117

Notes:

HOL3321C

CALSONIC

To suit Holden Commodore VY SI & II
V6 3.8L 9/2002 - 8/2004



Core Height	675mm	Core Width	430mm
Core Thickness	19mm 1 Row	Inlet / Outlet	37 / 37
Oil Cooler	N/A		
Condenser	CNX228	Receiver Drier	RDX117

Notes:

HOL3323C

CALSONIC

To suit Holden Commodore VY SI & II Gen III
V8 5.7L 9/2002 - 12/2004



Core Height	670mm	Core Width	430mm
Core Thickness	35mm 2 Row	Inlet / Outlet	37 / 37
Oil Cooler	N/A		
Condenser	CNX228	Receiver Drier	RDX117

Notes:

HOL3322C

To suit Holden Commodore VY V8 Gen III
V8 5.7L 9/2002 - 12/2004

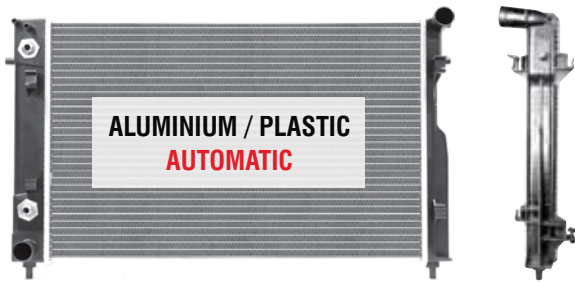

Core Height	670mm	Core Width	430mm
Core Thickness	35mm 2 Row	Inlet / Outlet	37 / 37
Oil Cooler	295mm		
Condenser	CNX228	Receiver Drier	RDX117

Notes:

HOL24820

To suit Holden Commodore VY Gen III
V8 5.7L 9/2002 - 12/2004



Core Height	675mm	Core Width	430mm
Core Thickness	32mm 1 Row	Inlet / Outlet	35 / 35
Oil Cooler	295mm		
Condenser	CNX228	Receiver Drier	RDX117

Notes: Stainless Steel Plate Cooler

15-HOL24820

To suit Holden Commodore VY Gen III
V8 5.7L 9/2002 - 12/2004



Core Height	675mm	Core Width	430mm
Core Thickness	32mm 1 Row	Inlet / Outlet	35 / 35
Oil Cooler	295mm		
Condenser	CNX228	Receiver Drier	RDX117

Notes: Stainless Steel Cooler

HOL24830

To suit Holden Commodore VY Gen III
V8 5.7L 9/2002 - 12/2004



Core Height	675mm	Core Width	430mm
Core Thickness	32mm 1 Row	Inlet / Outlet	35 / 35
Oil Cooler	N/A		
Condenser	CNX228	Receiver Drier	RDX117

Notes:

HOL24700

To suit Holden Commodore VU - VX SII
V6 3.8L inc Supercharged 8/2000 - 9/2002



Core Height	675mm	Core Width	430mm
Core Thickness	24mm 1 Row	Inlet / Outlet	35 / 35
Oil Cooler	305/305mm		
Condenser	CNX030	Receiver Drier	RDX106

Notes:

15-HOL24700

To suit Holden Commodore VU - VX SII
V6 3.8L inc Supercharged 8/2000 - 9/2002



Core Height	675mm	Core Width	430mm
Core Thickness	24mm 1 Row	Inlet / Outlet	35 / 35
Oil Cooler	305/305mm		
Condenser	CNX030	Receiver Drier	RDX106

Notes: Stainless Steel Cooler

HOL3298C

To suit Holden Commodore VU - VX SII
3.8L inc Supercharged 8/2000 - 9/2002



Core Height	675mm	Core Width	430mm
Core Thickness	24mm 1 Row	Inlet / Outlet	35 / 35
Oil Cooler	305/305mm		
Condenser	CNX030	Receiver Drier	RDX106

Notes:

HOL24705

To suit Holden Commodore VU - VX SII
V6 3.8L 8/2000 - 9/2002



Core Height	675mm	Core Width	430mm
Core Thickness	24mm 1 Row	Inlet / Outlet	35 / 35
Oil Cooler	N/A		
Condenser	CNX030	Receiver Drier	RDX106

Notes:

HOL3299C

To suit Holden Commodore VU - VX
SI & II Gen II
V8 5.7L 8/2000 - 9/2002



Core Height	675mm	Core Width	430mm
Core Thickness	35mm 1 Row	Inlet / Outlet	36 / 36
Oil Cooler	305mm		
Condenser	CNX030	Receiver Drier	RDX106

Notes:

HOL3300C

To suit Holden Commodore VU - VX
SI & II Gen III
V8 5.7L 8/2000 - 9/2002



Core Height	675mm	Core Width	430mm
Core Thickness	35mm 1 Row	Inlet / Outlet	36 / 36
Oil Cooler	N/A		
Condenser	CNX030	Receiver Drier	RDX106

Notes:

HOL24710

To suit Holden Commodore VU - VX Gen III
V8 5.7L 8/2000 - 9/2002



Core Height	675mm	Core Width	430mm
Core Thickness	32mm 1 Row	Inlet / Outlet	35 / 35
Oil Cooler	305mm		
Condenser	CNX030	Receiver Drier	RDX106

Notes:

HOL24715

To suit Holden Commodore VU - VX Gen III
V8 5.7L 8/2000 - 9/2002



Core Height	675mm	Core Width	430mm
Core Thickness	32mm 1 Row	Inlet / Outlet	35 / 35
Oil Cooler	N/A		
Condenser	CNX030	Receiver Drier	RDX106

Notes:

HOL24520

To suit Holden Commodore VT
V.8 5.0L 8/1997 - 5/2000



Core Height	675mm	Core Width	430mm
Core Thickness	32mm 1 Row	Inlet / Outlet	35 / 35
Oil Cooler	275 / 275mm		
Condenser	CNX030	Receiver Drier	RDX106

Notes: Stainless Steel Plate Coolers

HOL24530

To suit Holden Commodore VT
V.8 5.0L 8/1997 - 5/2000



Core Height	675mm	Core Width	430mm
Core Thickness	32mm 1 Row	Inlet / Outlet	35 / 35
Oil Cooler	N/A		
Condenser	CNX030	Receiver Drier	RDX106

Notes:

HOL3292C

To suit Holden Commodore VT
V.8 5.0L 8/1997 - 5/2000



Core Height	675mm	Core Width	425mm
Core Thickness	35mm 1 Row	Inlet / Outlet	37 / 37
Oil Cooler	275/275mm		
Condenser	CNX030	Receiver Drier	RDX106

Notes:

HOL3291C

To suit Holden Commodore VT
V.8 5.0L 8/1997 - 5/2000



Core Height	675mm	Core Width	425mm
Core Thickness	35mm 1 Row	Inlet / Outlet	37 / 37
Oil Cooler	N/A		
Condenser	CNX030	Receiver Drier	RDX106

Notes:

HOL3289C

To suit Holden Commodore VT
V6 3.8L inc Supercharged 8/1997 - 10/2000



Core Height	675mm	Core Width	425mm
Core Thickness	25mm 1 Row	Inlet / Outlet	36 / 36
Oil Cooler	305mm		
Condenser	CNX030	Receiver Drier	RDX106

Notes:

HOL24600

To suit Holden Commodore VT
V6 3.8L inc Supercharged 8/1997 - 10/2000



Core Height	675mm	Core Width	425mm
Core Thickness	25mm 1 Row	Inlet / Outlet	36 / 36
Oil Cooler	305mm		
Condenser	CNX030	Receiver Drier	RDX106

Notes: Stainless Steel Plate Cooler

HOL1833



To suit Holden Commodore VT
V6 3.8L inc Supercharged 8/1997 - 10/2000



Core Height	675mm	Core Width	425mm
Core Thickness	25mm 1 Row	Inlet / Outlet	35 / 35
Oil Cooler	305 / 305mm		
Condenser	CNX030	Receiver Drier	RDX106

Notes: 2 Oil Coolers

15-HOL24600



To suit Holden Commodore VT
V6 3.8L inc Supercharged 8/1997 - 10/2000



Core Height	675mm	Core Width	425mm
Core Thickness	25mm 1 Row	Inlet / Outlet	36 / 36
Oil Cooler	305mm		
Condenser	CNX030	Receiver Drier	RDX106

Notes: Stainless Steel Cooler

HOL24500



To suit Holden Commodore VT
V6 3.8L inc Supercharged 8/1997 - 10/2000



Core Height	675mm	Core Width	430mm
Core Thickness	24mm 1 Row	Inlet / Outlet	36 / 36
Oil Cooler	275 / 275mm		
Condenser	CNX030	Receiver Drier	RDX106

Notes: 2 Oil Coolers

HOL3290C



To suit Holden Commodore VT
V6 3.8L 8/1997 - 10/2000



Core Height	675mm	Core Width	425mm
Core Thickness	25mm 1 Row	Inlet / Outlet	37 / 37
Oil Cooler	N/A		
Condenser	CNX030	Receiver Drier	RDX106

Notes:

15-HOL24500



To suit Holden Commodore VT
V6 3.8L inc Supercharged 8/1997 - 10/2000



Core Height	675mm	Core Width	430mm
Core Thickness	24mm 1 Row	Inlet / Outlet	36 / 36
Oil Cooler	275 / 275mm		
Condenser	CNX030	Receiver Drier	RDX106

Notes: 2 Oil Coolers

HOL3293C



To suit Holden Commodore VT Gen III
V8 5.7L 6/1999 - 10/2000



Core Height	675mm	Core Width	430mm
Core Thickness	35mm 1 Row	Inlet / Outlet	37 / 37
Oil Cooler	305/305mm		
Condenser	CNX030	Receiver Drier	RDX106

Notes:

HOL24540

To suit Holden Commodore VT - VX Gen III
V8 5.7L 6/1999 - 10/2000



ALUMINIUM / PLASTIC
AUTOMATIC

Core Height	675mm	Core Width	430mm
Core Thickness	32mm 1 Row	Inlet / Outlet	35 / 35
Oil Cooler	305/305mm		
Condenser	CNX030	Receiver Drier	RDX106

Notes:

HOL24550

To suit Holden Commodore VT - VX Gen III
V8 5.7L 6/1999 - 10/2000



ALUMINIUM / PLASTIC
MANUAL

Core Height	675mm	Core Width	430mm
Core Thickness	32mm 1 Row	Inlet / Outlet	35 / 35
Oil Cooler	N/A		
Condenser	CNX030	Receiver Drier	RDX106

Notes:

HOL24300

To suit Holden Commodore VS SII
V6 3.8L 4/1995 - 12/2000



ALUMINIUM / PLASTIC
AUTOMATIC

Core Height	548mm	Core Width	420mm
Core Thickness	24mm 1 Row	Inlet / Outlet	35 / 40
Oil Cooler	275mm		
Condenser	CNX028	Receiver Drier	RDX101

Notes: Screw on Oil Cooler Fittings

15-HOL24300

To suit Holden Commodore VS SII
V6 3.8L 4/1995 - 12/2000

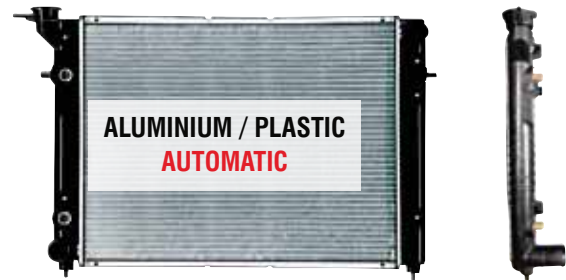

ALUMINIUM / PLASTIC
AUTOMATIC

Core Height	548mm	Core Width	420mm
Core Thickness	24mm 1 Row	Inlet / Outlet	35 / 40
Oil Cooler	275mm		
Condenser	CNX028	Receiver Drier	RDX101

Notes: Screw on Oil Cooler Fittings

HOL24200

To suit Holden Commodore VP - VS SI
V6 3.8L 10/1991 - 12/2000



ALUMINIUM / PLASTIC
AUTOMATIC

Core Height	545mm	Core Width	420mm
Core Thickness	24mm 1 Row	Inlet / Outlet	35 / 39
Oil Cooler	275mm		
Condenser	CNX028	Receiver Drier	RDX101

Notes: Push on Oil Lines

15-HOL24200

To suit Holden Commodore VP - VS SI
V6 3.8L 10/1991 - 12/2000



ALUMINIUM / PLASTIC
AUTOMATIC

Core Height	545mm	Core Width	420mm
Core Thickness	24mm 1 Row	Inlet / Outlet	35 / 39
Oil Cooler	275mm		
Condenser	CNX028	Receiver Drier	RDX101

Notes: Push on Oil Lines

HOL24400

To suit Holden Commodore VN - VS SIII
V8 5.0L 3/1989 - 12/2000



ALUMINIUM / PLASTIC
AUTOMATIC

Core Height	550mm	Core Width	420mm
Core Thickness	32mm 1 Row	Inlet / Outlet	40 / 40
Oil Cooler	275mm		
Condenser	CNX028	Receiver Drier	RDX101

Notes: Screw on Oil Cooler Fittings

HOL24100

To suit Holden Commodore VN
V6 3.8L 8/1988 - 10/1991



ALUMINIUM / PLASTIC
AUTOMATIC

Core Height	545mm	Core Width	420mm
Core Thickness	24mm 1 Row	Inlet / Outlet	35 / 39
Oil Cooler	250mm		
Condenser	CNX027	Receiver Drier	RDX104

Notes: Push on Oil Fittings

HOL26270

To suit Holden Commodore VL - VR
V8 5.0L 3/1986 - 4/1995



COPPER / BRASS
AUTOMATIC

Core Height	545mm	Core Width	435mm
Core Thickness	45mm 3 Row	Inlet / Outlet	39 / 39
Oil Cooler	190mm		
Condenser	CNX029	Receiver Drier	RDX104

Notes:

HOL26260

To suit Holden Commodore VB - VK
6 cyl 1.9, 2.8 & 3.3L 11/1978 - 3/1986

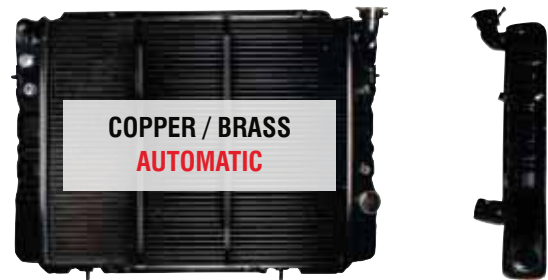

COPPER / BRASS
AUTOMATIC

Core Height	540mm	Core Width	440mm
Core Thickness	45mm 3 Row	Inlet / Outlet	33 / 39
Oil Cooler	140mm		
Condenser	CNX305	Receiver Drier	RDX033

Notes:

H39CA

To suit Holden Cruze YG
4 cyl 1.5L 7/2002 - 6/2007



ALUMINIUM / PLASTIC
AUTOMATIC

Core Height	375mm	Core Width	350mm
Core Thickness	27mm 1 Row	Inlet / Outlet	28 / 28
Oil Cooler	250mm		
Condenser	CNX233	Receiver Drier	RDX115

Notes:

H39CM

To suit Holden Cruze YG
4 cyl 1.5L 7/2002 - 6/2007



ALUMINIUM / PLASTIC
MANUAL

Core Height	375mm	Core Width	350mm
Core Thickness	27mm 1 Row	Inlet / Outlet	28 / 28
Oil Cooler	N/A		
Condenser	CNX233	Receiver Drier	RDX115

Notes:

HOL1823

To suit Holden Frontera
V6 3.2L 2/1999 - 4/2004



Core Height	425mm	Core Width	620mm
Core Thickness	36mm 2 Row	Inlet / Outlet	39 / 39
Oil Cooler	350mm		
Condenser	CNX046	Receiver Drier	RDX022

Notes:

HOL08601

To suit Holden Frontera M7 UES
4 cyl 2.0 & 2.2L 10/1995 - 4/2004



Core Height	424mm	Core Width	595mm
Core Thickness	32mm 1 Row	Inlet / Outlet	34 / 34
Oil Cooler	N/A		
Condenser		Receiver Drier	

Notes:

HOL1953

To suit Holden Jackaroo UBSII,
UBS25, UBS26, UBS69
V6 3.2 & 3.5L & 3.1L Turbo Diesel 4/1992 - 4/2004

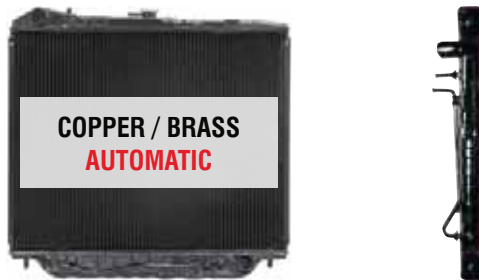

Core Height	500mm	Core Width	620mm
Core Thickness	32mm 2 Row	Inlet / Outlet	38 / 38
Oil Cooler	360mm		
Condenser	CNX050	Receiver Drier	RDX604

Notes:

HOL1765

To suit Holden Jackaroo UBS26 UBS73
V6 3.5L & 4 cyl 3.0L Turbo Diesel 1/1998 - 2001



Core Height	480mm	Core Width	630mm
Core Thickness	27mm 1 Row	Inlet / Outlet	38 / 38
Oil Cooler	375mm		
Condenser	CNX050	Receiver Drier	RDX604

Notes:

HOL1764

To suit Holden Jackaroo UBS26 UBS73
V6 3.5L & 4 cyl 3.0L Turbo Diesel 1/1998 - 2001



Core Height	480mm	Core Width	630mm
Core Thickness	27mm 1 Row	Inlet / Outlet	38 / 38
Oil Cooler	N/A		
Condenser	CNX050	Receiver Drier	RDX604

Notes:

E29CA2

To suit Holden Nova LG
4 cyl 1.6 & 1.8L 10/1994 - 9/1996



Core Height	350mm	Core Width	640mm
Core Thickness	16mm 1 Row	Inlet / Outlet	31 / 31
Oil Cooler	225mm		
Condenser	CNX060	Receiver Drier	RDX604

Notes:

TOY60218

To suit Holden Nova LG
4 cyl 1.6 & 1.8L 10/1994 - 9/1996



Core Height	350mm	Core Width	642mm
Core Thickness	16mm 1 Row	Inlet / Outlet	31 / 31
Oil Cooler	225mm		
Condenser	CNX060	Receiver Drier	RDX604

Notes:

15-TOY60218

To suit Holden Nova LG
4 cyl 1.6 & 1.8L 10/1994 - 9/1996



Core Height	350mm	Core Width	642mm
Core Thickness	16mm 1 Row	Inlet / Outlet	31 / 31
Oil Cooler	225mm		
Condenser	CNX060	Receiver Drier	RDX604

Notes:

TOY60220

To suit Holden Nova LG
4 cyl 1.6 & 1.8L 10/1994 - 9/1996



Core Height	350mm	Core Width	638mm
Core Thickness	16mm 1 Row	Inlet / Outlet	32 / 32
Oil Cooler	N/A		
Condenser	CNX060	Receiver Drier	RDX604

Notes:

TOY60214

To suit Holden Nova LE, LF
4 cyl 1.6 & 1.8L 8/1989 - 10/1994



Core Height	325mm	Core Width	665mm
Core Thickness	16mm 1 Row	Inlet / Outlet	31 / 31
Oil Cooler	225mm	Receiver Drier	RDX284 (R134a)
Condenser	CNX056 / CNX059	Receiver Drier	RDX282 (R12)

Notes: Condenser options CNX056 (R12) / CNX059 (R134a)

15-TOY60214

To suit Holden Nova LE, LF
4 cyl 1.6 & 1.8L 8/1989 - 10/1994



Core Height	325mm	Core Width	665mm
Core Thickness	16mm 1 Row	Inlet / Outlet	31 / 31
Oil Cooler	225mm	Receiver Drier	RDX284 (R134a)
Condenser	CNX056 / CNX059	Receiver Drier	RDX282 (R12)

Notes: Condenser options CNX056 (R12) CNX059 (R134a)

TOY60216

To suit Holden Nova LE LF
4 cyl 1.6 & 1.8L 8/1989 - 10/1994



Core Height	325mm	Core Width	665mm
Core Thickness	16mm 1 Row	Inlet / Outlet	31 / 31
Oil Cooler	N/A	Receiver Drier	RDX284 (R134a)
Condenser	CNX056 / CNX059	Receiver Drier	RDX282 (R12)

Notes: Condenser options CNX056 (R12) CNX059 (R134a)

HOL2696

To suit Holden Rodeo R9 RA
4 cyl 2.4L 3.0L Turbo Diesel V6 3.5 & 3.6L
12/2001 - 12/2008



Core Height	475mm	Core Width	590mm
Core Thickness	26mm 1 Row	Inlet / Outlet	36 / 36
Oil Cooler	350mm		
Condenser	CNX237 / CNX236	Receiver Drier	RDX118

Notes: Condenser options CNX237 (DSL) / CNX236 (Petrol)

HOL2695

To suit Holden Rodeo R9 RA
4 cyl 3.0L Turbo Diesel & V6 3.5L
12/2001 - 7/2008



Core Height	475mm	Core Width	592mm
Core Thickness	26mm 1 Row	Inlet / Outlet	38 / 38
Oil Cooler	350mm		
Condenser	CNX237	Receiver Drier	RDX118

Notes: Sender Port Drivers Side Top Tank

HOL1823

To suit Holden Rodeo R7, R9
V6 3.2L 2/1998 - 2/2004



Core Height	425mm	Core Width	620mm
Core Thickness	36mm 2 Row	Inlet / Outlet	39 / 39
Oil Cooler	350mm		
Condenser	CNX046	Receiver Drier	RDX022

Notes:

HOL25060

To suit Holden Rodeo TF R7, R9
V6 3.2L 2/1998 - 2/2004



Core Height	425mm	Core Width	615mm
Core Thickness	35mm 2 Row	Inlet / Outlet	38 / 38
Oil Cooler	365mm		
Condenser	CNX046	Receiver Drier	RDX022

Notes:

HOL25050

To suit Holden Rodeo G3, G6
4 cyl 2.6L 1/1993 - 1/1997

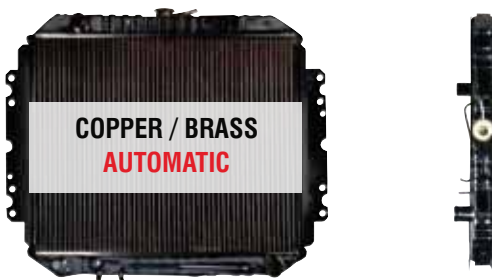

Core Height	420mm	Core Width	540mm
Core Thickness	32mm 2 Row	Inlet / Outlet	33 / 33
Oil Cooler	300mm		
Condenser	CNX402	Receiver Drier	RDX022

Notes:

HOL25040

To suit Holden Rodeo G3, G6
4 cyl 2.8L Turbo Diesel 1/1993 - 1/1997



Core Height	420mm	Core Width	540mm
Core Thickness	32mm 2 Row	Inlet / Outlet	32 / 32
Oil Cooler	N/A		
Condenser	CNX230	Receiver Drier	RDX022

Notes:

HOL25040

To suit Holden Rodeo TF R7, R9
4 cyl 2.8L Turbo Diesel 5/1990 - 1/2004



Core Height	420mm	Core Width	540mm
Core Thickness	32mm 2 Row	Inlet / Outlet	32 / 32
Oil Cooler	N/A		
Condenser	CNX230	Receiver Drier	RDX022

Notes:

HOL25050

To suit Holden Rodeo TF R7
4 cyl 2.6L 7/1988 - 12/1998

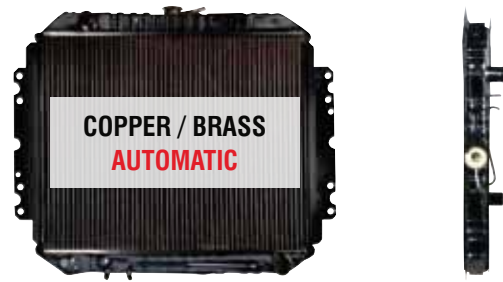

Core Height	420mm	Core Width	540mm
Core Thickness	32mm 2 Row	Inlet / Outlet	33 / 33
Oil Cooler	300mm		
Condenser	CNX402	Receiver Drier	RDX022

Notes:

HOL24885

To suit Holden Statesman WM
V8 6.0L 8/2006 >



Core Height	380mm	Core Width	755mm
Core Thickness	42mm 2 Row	Inlet / Outlet	35 / 35
Oil Cooler	450mm		
Condenser	CNX235	Receiver Drier	RDX113

Notes:

HOL24882

To suit Holden Statesman WM
V6 3.6L 8/2006 >

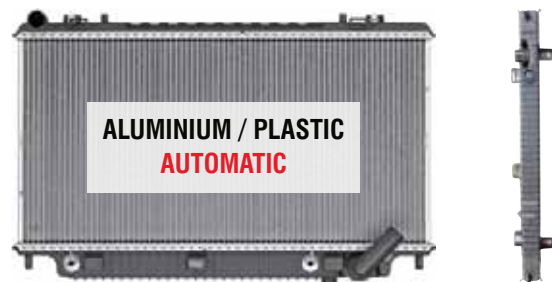

Core Height	385mm	Core Width	755mm
Core Thickness	26mm 1 Row	Inlet / Outlet	35 / 35
Oil Cooler	450mm		
Condenser	CNX235	Receiver Drier	RDX113

Notes:

HOL24850

To suit Holden Statesman WL
V6 3.6L 8/2004 - 8/2006



Core Height	675mm	Core Width	430mm
Core Thickness	32mm 1 Row	Inlet / Outlet	35 / 35
Oil Cooler	295mm		
Condenser	CNX231	Receiver Drier	RDX106

Notes: Stainless Steel Plate Cooler

15-HOL24850

To suit Holden Statesman WL
V6 3.6L 8/2004 - 8/2006



Core Height	675mm	Core Width	430mm
Core Thickness	32mm 1 Row	Inlet / Outlet	35 / 35
Oil Cooler	295mm		
Condenser	CNX231	Receiver Drier	RDX106

Notes: Stainless Steel Cooler

HOL3326C

To suit Holden Statesman WL
V6 3.6L 8/2004 - 8/2006



ALUMINIUM / PLASTIC
AUTOMATIC

Core Height	675mm	Core Width	431mm
Core Thickness	27mm 1 Row	Inlet / Outlet	35 / 35
Oil Cooler	290mm		
Condenser	CNX231	Receiver Drier	RDX106

Notes:

HOL24870

To suit Holden Statesman WL Gen III
V8 5.7 & 6.0L 8/2004 - 8/2006



ALUMINIUM / PLASTIC
AUTOMATIC

Core Height	675mm	Core Width	430mm
Core Thickness	32mm 1 Row	Inlet / Outlet	35 / 35
Oil Cooler	290mm		
Condenser	CNX231	Receiver Drier	RDX106

Notes: Stainless Steel Plate Cooler

HOL3325C

To suit Holden Statesman WL Gen III
V8 5.7 & 6.0L 8/2004 - 8/2006



ALUMINIUM / PLASTIC
AUTOMATIC

Core Height	675mm	Core Width	430mm
Core Thickness	35mm 2 Row	Inlet / Outlet	35 / 35
Oil Cooler	290mm		
Condenser	CNX231	Receiver Drier	RDX106

Notes:

HOL24800

To suit Holden Statesman WK
V6 3.8L inc Supercharged 4/2003 - 8/2004



ALUMINIUM / PLASTIC
AUTOMATIC

Core Height	675mm	Core Width	430mm
Core Thickness	24mm 1 Row	Inlet / Outlet	35 / 35
Oil Cooler	295mm		
Condenser	CNX228	Receiver Drier	RDX117

Notes: Stainless Steel Plate Cooler

15-HOL24800

To suit Holden Statesman WK
V6 3.8L inc Supercharged 4/2003 - 8/2004



ALUMINIUM / PLASTIC
AUTOMATIC

Core Height	675mm	Core Width	430mm
Core Thickness	24mm 1 Row	Inlet / Outlet	35 / 35
Oil Cooler	295mm		
Condenser	CNX228	Receiver Drier	RDX117

Notes: Stainless Steel Cooler

HOL3320C

To suit Holden Statesman WK
Supercharged V6 3.8L 4/2003 - 8/2004



ALUMINIUM / PLASTIC
AUTOMATIC

Core Height	675mm	Core Width	430mm
Core Thickness	19mm 1 Row	Inlet / Outlet	35 / 35
Oil Cooler	290mm		
Condenser	CNX228	Receiver Drier	RDX117

Notes:

HOL24820

To suit Holden Statesman WK Gen III
V8 5.7L 4/2003 - 8/2004



ALUMINIUM / PLASTIC
AUTOMATIC

Core Height	675mm	Core Width	430mm
Core Thickness	32mm 1 Row	Inlet / Outlet	35 / 35
Oil Cooler	295mm		
Condenser	CNX228	Receiver Drier	RDX117

Notes: Stainless Steel Plate Cooler

15-HOL24820

To suit Holden Statesman WK Gen III
V8 5.7L 4/2003 - 8/2004



ALUMINIUM / PLASTIC
AUTOMATIC

Core Height	675mm	Core Width	430mm
Core Thickness	32mm 1 Row	Inlet / Outlet	35 / 35
Oil Cooler	295mm		
Condenser	CNX228	Receiver Drier	RDX117

Notes: Stainless Steel Cooler

HOL24520

To suit Holden Statesman WH
V6 3.8L inc Supercharged 6/1999 - 4/2004



ALUMINIUM / PLASTIC
AUTOMATIC

Core Height	675mm	Core Width	430mm
Core Thickness	32mm 1 Row	Inlet / Outlet	35 / 35
Oil Cooler	275 / 275mm		
Condenser	CNX030	Receiver Drier	RDX106

Notes: Stainless Steel Plate Coolers

HOL3292C

To suit Holden Statesman WH
V6 3.8L inc Supercharged 6/1999 - 4/2004

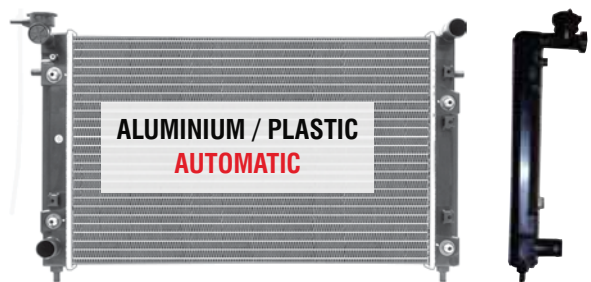

ALUMINIUM / PLASTIC
AUTOMATIC

Core Height	675mm	Core Width	425mm
Core Thickness	35mm 1 Row	Inlet / Outlet	37 / 37
Oil Cooler	275 / 275mm		
Condenser	CNX030	Receiver Drier	RDX106

Notes:

HOL24540

To suit Holden Statesman WH Gen III
V8 5.7L 6/1999 - 4/2004



ALUMINIUM / PLASTIC
AUTOMATIC

Core Height	675mm	Core Width	430mm
Core Thickness	32mm 1 Row	Inlet / Outlet	35 / 35
Oil Cooler	305 / 305mm		
Condenser	CNX030	Receiver Drier	RDX106

Notes:

HOL24710

To suit Holden Statesman WH Gen III
V8 5.7L 6/1999 - 4/2004



ALUMINIUM / PLASTIC
AUTOMATIC

Core Height	675mm	Core Width	430mm
Core Thickness	32mm 1 Row	Inlet / Outlet	35 / 35
Oil Cooler	305mm		
Condenser	CNX030	Receiver Drier	RDX106

Notes:

HOL3293C

To suit Holden Statesman WH Gen III
V8 5.7L 6/1999 - 4/2004



Core Height	675mm	Core Width	430mm
Core Thickness	35mm 1 Row	Inlet / Outlet	37 / 37
Oil Cooler	305/305mm		
Condenser	CNX030	Receiver Drier	RDX106

Notes:

HOL24700

To suit Holden Statesman WH - WK
V6 3.8L inc Supercharged 6/1999 - 8/2004



Core Height	675mm	Core Width	430mm
Core Thickness	24mm 1 Row	Inlet / Outlet	35 / 35
Oil Cooler	305/305mm		
Condenser	CNX030	Receiver Drier	RDX106

Notes:

15-HOL24700

To suit Holden Statesman WH - WK
V6 3.8L inc Supercharged 6/1999 - 8/2004



Core Height	675mm	Core Width	430mm
Core Thickness	24mm 1 Row	Inlet / Outlet	35 / 35
Oil Cooler	305/305mm		
Condenser	CNX030	Receiver Drier	RDX106

Notes: Stainless Steel Cooler

HOL3298C

To suit Holden Statesman WH - WK
V6 3.8L inc Supercharged 6/1999 - 8/2004



Core Height	675mm	Core Width	430mm
Core Thickness	24mm 1 Row	Inlet / Outlet	35 / 35
Oil Cooler	305/305mm		
Condenser	CNX030	Receiver Drier	RDX106

Notes:

HOL26270

To suit Holden Statesman VQ - VR
V8 5.0L 3/1994 - 4/1995



Core Height	545mm	Core Width	435mm
Core Thickness	45mm 3 Row	Inlet / Outlet	39 / 39
Oil Cooler	190mm		
Condenser	CNX029	Receiver Drier	RDX104

Notes:

HOL24300

To suit Holden Statesman VR - VS
V6 3.8L inc Supercharged 3/1994 - 6/1999



Core Height	548mm	Core Width	420mm
Core Thickness	24mm 1 Row	Inlet / Outlet	35 / 40
Oil Cooler	275mm		
Condenser	CNX028	Receiver Drier	RDX101

Notes: Screw on Oil Cooler Fittings

15-HOL24300

To suit Holden Statesman VR - VS
V6 3.8L inc Supercharged 3/1994 - 6/1999

revolution

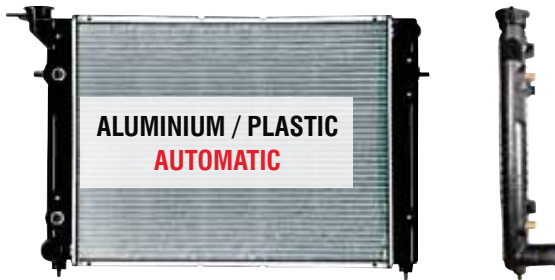

ALUMINIUM / PLASTIC
AUTOMATIC

Core Height	548mm	Core Width	420mm
Core Thickness	24mm 1 Row	Inlet / Outlet	35 / 40
Oil Cooler	275mm		
Condenser	CNX028	Receiver Drier	RDX101

Notes: Screw on Oil Cooler Fittings

HOL24200

To suit Holden Statesman VQ SII - VS
V6 3.8L 1/1992 - 6/1999

OEX



ALUMINIUM / PLASTIC
AUTOMATIC

Core Height	545mm	Core Width	420mm
Core Thickness	24mm 1 Row	Inlet / Outlet	35 / 39
Oil Cooler	275mm		
Condenser	CNX028	Receiver Drier	RDX101

Notes: Push on Oil Fittings

15-HOL24200

To suit Holden Statesman VQ SII - VS
V6 3.8L 1/1992 - 6/1999

revolution



ALUMINIUM / PLASTIC
AUTOMATIC

Core Height	545mm	Core Width	420mm
Core Thickness	24mm 1 Row	Inlet / Outlet	35 / 39
Oil Cooler	275mm		
Condenser	CNX028	Receiver Drier	RDX101

Notes: Push on Oil Fittings

HOL24400

To suit Holden Statesman VQ - VS SI
V8 5.0L 3/1990 - 6/1999

OEX



ALUMINIUM / PLASTIC
AUTOMATIC

Core Height	550mm	Core Width	420mm
Core Thickness	32mm 1 Row	Inlet / Outlet	40 / 40
Oil Cooler	275mm		
Condenser	CNX028	Receiver Drier	RDX101

Notes: Screw on Oil Cooler Fittings

HOL14361

To suit Holden Tigra XC
4 cyl 1.8L 9/2005 - 1/2008

BEHR MELLER SERVICE



ALUMINIUM / PLASTIC
MANUAL

Core Height	540mm	Core Width	375mm
Core Thickness	26mm 1 Row	Inlet / Outlet	34 / 34
Oil Cooler	N/A		
Condenser	CNX306	Receiver Drier	RDX134

Notes:

HOL71211

To suit Holden Vectra ZC
4 cyl 2.2L & V6 3.2L 3/2003 - 3/2007

OEX



ALUMINIUM / PLASTIC
AUTOMATIC

Core Height	650mm	Core Width	405mm
Core Thickness	29mm 1 Row	Inlet / Outlet	35 / 35
Oil Cooler	255mm		
Condenser	CNX234	Receiver Drier	RDX163

Notes:

HOL20641

To suit Holden Vectra JR - JS SII
V6 2.5 & 2.6L 6/1997 - 3/2004



Core Height	610mm	Core Width	365mm
Core Thickness	28mm 1 Row	Inlet / Outlet	34 / 34
Oil Cooler	345mm		
Condenser	CNX032	Receiver Drier	RDX109

Notes:

HOL23005

To suit Holden Vectra JR - JS SII
V6 2.5 & 2.6L 6/1997 - 3/2004



Core Height	610mm	Core Width	355mm
Core Thickness	24mm 1 Row	Inlet / Outlet	34 / 34
Oil Cooler	245mm		
Condenser	CNX032	Receiver Drier	RDX109

Notes:

HOL23007

To suit Holden Vectra JR - JS SII
V6 2.5 & 2.6L 6/1997 - 3/2004



Core Height	610mm	Core Width	360mm
Core Thickness	24mm 1 Row	Inlet / Outlet	34 / 34
Oil Cooler	N/A		
Condenser	CNX032	Receiver Drier	RDX109

Notes:

HOL20401

To suit Holden Vectra JR
4 cyl 2.0L 6/1997 - 8/1998



Core Height	540mm	Core Width	375mm
Core Thickness	24mm 1 Row	Inlet / Outlet	34 / 34
Oil Cooler	245mm		
Condenser	CNX032	Receiver Drier	RDX109

Notes:

DAE0004

To suit Holden Viva JF
4 cyl 1.8L 10/2005 - 12/2009



Core Height	375mm	Core Width	700mm
Core Thickness	16mm 1 Row	Inlet / Outlet	34 / 34
Oil Cooler	290mm		
Condenser		Receiver Drier	RDX164

Notes:

DAE1004

To suit Holden Viva JF
4 cyl 1.8L 10/2005 - 12/2009



Core Height	375mm	Core Width	700mm
Core Thickness	16mm 1 Row	Inlet / Outlet	34 / 34
Oil Cooler	N/A		
Condenser		Receiver Drier	RDX164

Notes:

HOL10321

To suit Holden Zafira TT
4 cyl 2.2L 6/2001 - 3/2006



Core Height	600mm	Core Width	375mm
Core Thickness	26mm 2 Row	Inlet / Outlet	34 / 34
Oil Cooler	250mm		
Condenser	CNX206 / CNX047	Receiver Drier	RDX119 / RDX114

Notes:

15-HOL10321

To suit Holden Zafira TT
4 cyl 2.2L 6/2001 - 3/2006



Core Height	600mm	Core Width	375mm
Core Thickness	26mm 2 Row	Inlet / Outlet	34 / 34
Oil Cooler	250mm		
Condenser	CNX206 / CNX047	Receiver Drier	RDX119 / RDX114

Notes:

HOL10331

To suit Holden Zafira TT
4 cyl 2.2L 6/2001 - 3/2006



Core Height	600mm	Core Width	365mm
Core Thickness	34mm 1 Row	Inlet / Outlet	34 / 34
Oil Cooler	250mm		
Condenser	CNX206 / CNX047	Receiver Drier	RDX119 / RDX114

Notes:

H58CA

To suit Honda Accord Euro K24
4 cyl 2.4L 6/2008 >



Core Height	400mm	Core Width	765mm
Core Thickness	16mm 1 Row	Inlet / Outlet	32 / 32
Oil Cooler	320mm		
Condenser	CNX710	Receiver Drier	RDX0050

Notes: 2 x Mount brackets on grill side

H64CA

To suit Honda Accord
V6 3.5L 2/2008 >



Core Height	400mm	Core Width	766mm
Core Thickness	16mm 1 Row	Inlet / Outlet	32 / 32
Oil Cooler	325mm		
Condenser	CNX8210	Receiver Drier	RDX0050

Notes:

HON28060

To suit Honda Accord 7th Gen CM5 Euro
4 cyl 2.4L 1/2003 - 6/2008



Core Height	405mm	Core Width	720mm
Core Thickness	16mm 1 Row	Inlet / Outlet	32 / 32
Oil Cooler	325mm		
Condenser	CNX710	Receiver Drier	RDX0050

Notes:

HON28065

To suit Honda Accord CM6
V6 3.0L 1/1999 - 2/2008



ALUMINIUM / PLASTIC
AUTOMATIC

Core Height	380mm	Core Width	720mm
Core Thickness	24mm 1 Row	Inlet / Outlet	32 / 32
Oil Cooler	N/A		
Condenser	CNX710	Receiver Drier	RDX0040

Notes:

HON1839

To suit Honda Accord CG5
4 cyl 2.3L 12/1997 - 1/1999



ALUMINIUM / PLASTIC
AUTOMATIC

Core Height	375mm	Core Width	675mm
Core Thickness	16mm 1 Row	Inlet / Outlet	33 / 33
Oil Cooler	325mm		
Condenser	CNX616	Receiver Drier	RDX653

Notes:

H10CA

To suit Honda Accord CD7, CD9, CE1, CG5
4 cyl 2.2 & 2.3L 11/1993 - 1/1999



ALUMINIUM / PLASTIC
AUTOMATIC

Core Height	350mm	Core Width	680mm
Core Thickness	16mm 1 Row	Inlet / Outlet	34 / 34
Oil Cooler	325mm		
Condenser	CNX609	Receiver Drier	RDX653

Notes:

HON28001

To suit Honda Accord CD7, CE9, CE1, CG5
4 cyl 2.2 & 2.3L 11/1993 - 01/1999

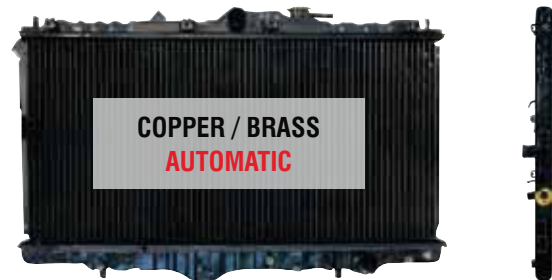

COPPER / BRASS
AUTOMATIC

Core Height	350mm	Core Width	680mm
Core Thickness	16mm 1 Row	Inlet / Outlet	33 / 33
Oil Cooler	325mm		
Condenser	CNX609	Receiver Drier	RDX653

Notes:

HON28004

To suit Honda Accord CB, CB7
4 cyl 2.2L 11/1989 - 6/1995



COPPER / PLASTIC
AUTOMATIC

Core Height	350mm	Core Width	670mm
Core Thickness	32mm 2 Row	Inlet / Outlet	33 / 33
Oil Cooler	325mm		
Condenser		Receiver Drier	RDX282

Notes:

HON28004

To suit Honda Ascot F20A
4 cyl 2.0L 1/1989 - 12/1995 (NZ)



COPPER / PLASTIC
AUTOMATIC

Core Height	350mm	Core Width	670mm
Core Thickness	32mm 2 Row	Inlet / Outlet	33 / 33
Oil Cooler	325mm		
Condenser		Receiver Drier	RDX282

Notes:

HON28010

To suit Honda Civic 8th Gen
4 cyl 2.0L 6/2007 >



Core Height	375mm	Core Width	670mm
Core Thickness	16mm 1 Row	Inlet / Outlet	33 / 33
Oil Cooler	300mm		
Condenser	CNX8180	Receiver Drier	RDX0050

Notes: Sender

H55CA

To suit Honda Civic 8th Gen
4 cyl 1.8 & 2.0L 2/2006 >



Core Height	375mm	Core Width	670mm
Core Thickness	16mm 1 Row	Inlet / Outlet	32 / 26 / 32
Oil Cooler	300mm		
Condenser	CNX8180	Receiver Drier	RDX0050

Notes:

H55CM

To suit Honda Civic 8th Gen
4 cyl 1.8 & 2.0L 2/2006 >



Core Height	375mm	Core Width	670mm
Core Thickness	16mm 1 Row	Inlet / Outlet	32 / 26 / 32
Oil Cooler	N/A		
Condenser	CNX8180	Receiver Drier	RDX0050

Notes:

H65CM

To suit Honda Civic 8th Gen
4 cyl 1.8 & 2.0L 2006 >



Core Height	375mm	Core Width	670mm
Core Thickness	26mm 2 Row	Inlet / Outlet	32 / 26 / 32
Oil Cooler	N/A		
Condenser	CNX8180	Receiver Drier	RDX0050

Notes:

H65CMAF

To suit Honda Civic 8th Gen
4 cyl 1.8 & 2.0L 2/2006 >



Core Height	375mm	Core Width	670mm
Core Thickness	26mm 2 Row	Inlet / Outlet	32 / 26 / 32
Oil Cooler	N/A		
Condenser	CNX8180	Receiver Drier	RDX0050

Notes: Includes Fan

H61CA

To suit Honda Civic Hybrid LDA2
4 cyl 1.3L 2/2006 >



Core Height	360mm	Core Width	660mm
Core Thickness	16mm 1 Row	Inlet / Outlet	28 / 28
Oil Cooler	375mm		
Condenser		Receiver Drier	

Notes:

HON28022

To suit Honda Civic 7th Gen D17
4 cyl 1.7L 11/2000 - 2/2006



Core Height	350mm	Core Width	660mm
Core Thickness	16mm 1 Row	Inlet / Outlet	28 / 28
Oil Cooler	325mm		
Condenser	CNX711	Receiver Drier	RDX653

Notes:

HON28020

To suit Honda Civic 7th Gen D17
4 cyl 1.7L 11/2000 - 2/2006



Core Height	350mm	Core Width	660mm
Core Thickness	16mm 1 Row	Inlet / Outlet	28 / 28
Oil Cooler	N/A		
Condenser	CNX711	Receiver Drier	RDX653

Notes:

HON28018

To suit Honda Civic ED - EK GLI VTI
4 cyl 1.3, 1.5 & 1.6L 10/1991 - 10/2000



Core Height	350mm	Core Width	355mm
Core Thickness	32mm 2 Row	Inlet / Outlet	28 / 28
Oil Cooler	200mm		
Condenser	CNX602	Receiver Drier	RDX602

Notes: Multi-Fit Fan Mounts

HON28019

To suit Honda Civic D15 EG - EK VTI
4 cyl 1.3, 1.5, 1.6L 10/1991 - 10/2000



Core Height	350mm	Core Width	345mm
Core Thickness	32mm 2 Row	Inlet / Outlet	28 / 28
Oil Cooler	N/A	Receiver Drier	RDX120
Condenser		Receiver Drier	RDX602

Notes: Multi-Fit Fan Mounts

HON28012

To suit Honda Civic D15 EG - EK VTI
4 cyl 1.3, 1.5 & 1.6L 10/1991 - 10/2000



Core Height	350mm	Core Width	350mm
Core Thickness	30mm 2 Row	Inlet / Outlet	32 / 32
Oil Cooler	N/A	Receiver Drier	RDX120
Condenser		Receiver Drier	RDX602

Notes:

HON28017

To suit Honda Civic AH EE
4 cyl 1.5L 5/1988 - 5/1990



Core Height	325mm	Core Width	670mm
Core Thickness	16mm 1 Row	Inlet / Outlet	28 / 28
Oil Cooler	N/A		
Condenser		Receiver Drier	RDX121

Notes:

HON28016

To suit Honda Civic ED
4 cyl 1.5L 1/1987 - 10/1993



Core Height	325mm	Core Width	670mm
Core Thickness	16mm 1 Row	Inlet / Outlet	28 / 28
Oil Cooler	325mm		
Condenser		Receiver Drier	RDX654

Notes:

H57CA

To suit Honda CRV K24
4 cyl 2.4L 2/2007 >



Core Height	400mm	Core Width	730mm
Core Thickness	16mm 1 Row	Inlet / Outlet	32 / 32
Oil Cooler	325mm		
Condenser	CNX717	Receiver Drier	RDX0040

Notes:

H57CM

To suit Honda CRV K24
4 cyl 2.4L 2/2007 >



Core Height	400mm	Core Width	730mm
Core Thickness	16mm 1 Row	Inlet / Outlet	32 / 32
Oil Cooler	N/A		
Condenser	CNX717	Receiver Drier	RDX0040

Notes:

HON1089

To suit Honda CRV K24
4 cyl 2.4L 2/2007 >



Core Height	400mm	Core Width	725mm
Core Thickness	16mm 1 Row	Inlet / Outlet	32 / 32
Oil Cooler	325mm		
Condenser	CNX600	Receiver Drier	RDX0040

Notes: Clip on pipe fitting

H40CA

To suit Honda CRV K24 RD7
4 cyl 2.4L 12/2001 - 2/2007



Core Height	400mm	Core Width	740mm
Core Thickness	16mm 1 Row	Inlet / Outlet	32 / 32
Oil Cooler	325mm		
Condenser	CNX600	Receiver Drier	RDX0040

Notes:

H40CM

To suit Honda CRV K24 RD7
4 cyl 2.4L 12/2001 - 2/2007



Core Height	400mm	Core Width	740mm
Core Thickness	16mm 1 Row	Inlet / Outlet	34 / 34
Oil Cooler	N/A		
Condenser	CNX600	Receiver Drier	RDX0040

Notes:

HON28030

To suit Honda CRV RD1
4 cyl 2.0L 10/1997 - 12/2001



Core Height	350mm	Core Width	670mm
Core Thickness	32mm 2 Row	Inlet / Outlet	36 / 36
Oil Cooler	325mm		
Condenser	CNX610	Receiver Drier	RDX653

Notes:

HON28019

To suit Honda HRV GH2 GH4
4 cyl 1.6L 1/1999 - 5/2002



Core Height	350mm	Core Width	345mm
Core Thickness	32mm 2 Row	Inlet / Outlet	28 / 28
Oil Cooler	N/A		
Condenser	CNX601	Receiver Drier	RDX120

Notes: Multi-Fit Fan Mounts

H46CA

To suit Honda Insight ECA121
3 cyl 1.0L 3/2001 - 8/2004



Core Height	325mm	Core Width	410mm
Core Thickness	16mm 1 Row	Inlet / Outlet	28 / 28
Oil Cooler	200mm		
Condenser		Receiver Drier	

Notes:

H46CM

To suit Honda Insight ECA121
3 cyl 1.0L 3/2001 - 8/2004



Core Height	325mm	Core Width	410mm
Core Thickness	16mm 1 Row	Inlet / Outlet	28 / 28
Oil Cooler	N/A		
Condenser		Receiver Drier	

Notes:

H44CA

To suit Honda Integra DC5 4th Gen
4 cyl 2.0L 8/2001 - 3/2007



Core Height	350mm	Core Width	698mm
Core Thickness	16mm 1 Row	Inlet / Outlet	33 / 33
Oil Cooler	325mm		
Condenser	CNX713	Receiver Drier	RDX653

Notes:

H44CM

To suit Honda Integra DC5 4th Gen
4 cyl 2.0L 8/2001 - 3/2007



Core Height	350mm	Core Width	698mm
Core Thickness	16mm 1 Row	Inlet / Outlet	33 / 33
Oil Cooler	N/A		
Condenser	CNX713	Receiver Drier	RDX653

Notes:

HON1204

To suit Honda Integra DC4 B18B
4 cyl 1.8L 7/1993 - 8/2001

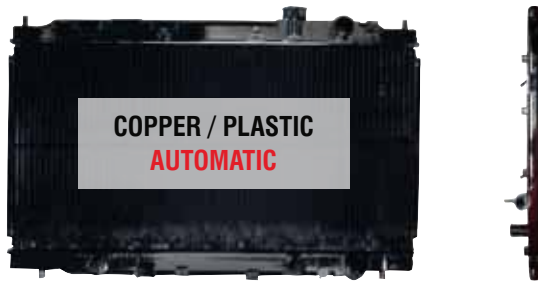

Core Height	350mm	Core Width	658mm
Core Thickness	16mm 1 Row	Inlet / Outlet	33 / 33
Oil Cooler	325mm		
Condenser	CNX610	Receiver Drier	RDX602

Notes:

H34CM

To suit Honda Integra DC2 DC4
4 cyl 1.8L 1/1993 - 8/2001



Core Height	350mm	Core Width	660mm
Core Thickness	16mm 1 Row	Inlet / Outlet	34 / 34
Oil Cooler	N/A		
Condenser	CNX610	Receiver Drier	RDX602

Notes:

H26CM

To suit Honda Integra
4 cyl 1.6 & 1.8L 5/1986 - 7/1993



Core Height	325mm	Core Width	670mm
Core Thickness	16mm 1 Row	Inlet / Outlet	33 / 33
Oil Cooler	N/A		
Condenser	CNX610	Receiver Drier	RDX123

Notes:

HON1789

To suit Honda Jazz GD1 GLI
4 cyl 1.3L 10/2002 - 8/2004



Core Height	325mm	Core Width	376mm
Core Thickness	26mm 1 Row	Inlet / Outlet	25 / 28 / 28
Oil Cooler	200mm		
Condenser	CNX5590	Receiver Drier	RDX0050

Notes:

HON28042

To suit Honda Jazz GD3
4 cyl 1.5L 10/2002 - 8/2008



Core Height	325mm	Core Width	655mm
Core Thickness	16mm 1 Row	Inlet / Outlet	25 / 28 / 28
Oil Cooler	N/A		
Condenser	CNX9531	Receiver Drier	RDX0050

Notes:

HON28040

To suit Honda Jazz GD3
4 cyl 1.5L 10/2002 - 8/2008



Core Height	325mm	Core Width	655mm
Core Thickness	16mm 1 Row	Inlet / Outlet	25 / 28 / 28
Oil Cooler	330mm		
Condenser	CNX9531	Receiver Drier	RDX0050

Notes:

H43CA

To suit Honda Legend KA9 KB1
V6 3.5L 5/1996 - 9/2008



ALUMINIUM / PLASTIC
AUTOMATIC

Core Height	450mm	Core Width	680mm
Core Thickness	16mm 1 Row	Inlet / Outlet	34 / 34
Oil Cooler	375mm		
Condenser		Receiver Drier	

Notes:

H30CA

To suit Honda Legend KA7 KA8
V6 3.2L 3/1991 - 5/1997



ALUMINIUM / PLASTIC
AUTOMATIC

Core Height	425mm	Core Width	680mm
Core Thickness	27mm 2 Row	Inlet / Outlet	32 / 32
Oil Cooler	375mm		
Condenser		Receiver Drier	

Notes:

HON28058

To suit Honda MDX YD1
V6 3.5L 4/2003 - 3/2007



ALUMINIUM / PLASTIC
AUTOMATIC

Core Height	500mm	Core Width	775mm
Core Thickness	24mm 1 Row	Inlet / Outlet	32 / 32
Oil Cooler	375mm		
Condenser		Receiver Drier	

Notes:

HON1127

To suit Honda Odyssey RB1 K24
4 cyl 2.4L 6/2004 - 4/2010



ALUMINIUM / PLASTIC
AUTOMATIC

Core Height	425mm	Core Width	765mm
Core Thickness	16mm 1 Row	Inlet / Outlet	32 / 32
Oil Cooler	325mm		
Condenser	CNX9300	Receiver Drier	RDX0050

Notes:

H47CM

To suit Honda Odyssey F23 RA3 RA8
4 cyl 2.3L & V6 3.0L 1/1998 - 12/2004



ALUMINIUM / PLASTIC
MANUAL

Core Height	450mm	Core Width	716mm
Core Thickness	16mm 1 Row	Inlet / Outlet	32 / 32
Oil Cooler	N/A		
Condenser	CNX714	Receiver Drier	RDX287

Notes:

HON28054

To suit Honda Odyssey F23 RA3 RA8
4 cyl 2.3L & V6 3.0L 1/1998 - 12/2004



ALUMINIUM / PLASTIC
AUTOMATIC

Core Height	450mm	Core Width	780mm
Core Thickness	16mm 1 Row	Inlet / Outlet	32 / 32
Oil Cooler	375mm		
Condenser	CNX714	Receiver Drier	RDX287

Notes:

H38CA

To suit Honda Odyssey RA1 RA3
4 cyl 2.2 & 2.3L 6/1995 - 6/2004



Core Height	450mm	Core Width	720mm
Core Thickness	16mm 1 Row	Inlet / Outlet	32 / 32
Oil Cooler	325mm		
Condenser	CNX615	Receiver Drier	RDX284

Notes:

H31CA

To suit Honda Odyssey RA1 RA3
4 cyl 2.2 & 2.3L 6/1995 - 6/2004



Core Height	425mm	Core Width	680mm
Core Thickness	25mm 1 Row	Inlet / Outlet	33 / 33
Oil Cooler	325mm		
Condenser	CNX615	Receiver Drier	RDX284

Notes:

H38CA

To suit Honda Prelude BB5
4 cyl 2.2L 2/1997 - 5/2002



Core Height	450mm	Core Width	718mm
Core Thickness	16mm 1 Row	Inlet / Outlet	32 / 32
Oil Cooler	325mm		
Condenser	CNX615	Receiver Drier	RDX284

Notes:

H28CA

To suit Honda Prelude
4 cyl 2.2 & 2.3L 12/1991 - 2/1997



Core Height	375mm	Core Width	700mm
Core Thickness	16mm 1 Row	Inlet / Outlet	33 / 33
Oil Cooler	325mm		
Condenser		Receiver Drier	RDX025

Notes:

H29CA

To suit Honda Prelude
4 cyl 2.0L 1/1986 - 12/1991



Core Height	350mm	Core Width	670mm
Core Thickness	16mm 1 Row	Inlet / Outlet	33 / 33
Oil Cooler	325mm		
Condenser	CNX614	Receiver Drier	RDX025

Notes:

HYU0034

To suit Hyundai Accent MC
4 cyl 1.6L 5/2006 >



Core Height	370mm	Core Width	650mm
Core Thickness	26mm 1 Row	Inlet / Outlet	33 / 33
Oil Cooler	370mm		
Condenser	CNX145	Receiver Drier	

Notes:

HYU1034

To suit Hyundai Accent MC
4 cyl 1.6L 5/2006>



Core Height	370mm	Core Width	650mm
Core Thickness	14mm 1 Row	Inlet / Outlet	33 / 33
Oil Cooler	N/A		
Condenser	CNX148	Receiver Drier	

Notes:

HYU0003

To suit Hyundai Accent LC LCS
4 cyl 1.5 & 1.6L 5/2000 - 5/2007



Core Height	340mm	Core Width	640mm
Core Thickness	16mm 1 Row	Inlet / Outlet	33 / 33
Oil Cooler	360mm		
Condenser	CNX146	Receiver Drier	RDX0050

Notes:

HYU1003

To suit Hyundai Accent LC LCS
4 cyl 1.5 & 1.6L 5/2000 - 5/2007



Core Height	330mm	Core Width	325mm
Core Thickness	18mm 1 Row	Inlet / Outlet	33 / 33
Oil Cooler	N/A		
Condenser	CNX146	Receiver Drier	RDX491

Notes:

HYU0035

To suit Hyundai Elantra HD
4 cyl 2.0L 9/2006>



Core Height	600mm	Core Width	455mm
Core Thickness	14mm 1 Row	Inlet / Outlet	33 / 33
Oil Cooler	335mm		
Condenser	CNX122	Receiver Drier	RDX0050

Notes:

HYU1035

To suit Hyundai Elantra HD
4 cyl 2.0L 9/2006>



Core Height	600mm	Core Width	455mm
Core Thickness	14mm 1 Row	Inlet / Outlet	33 / 33
Oil Cooler	N/A		
Condenser	CNX122	Receiver Drier	RDX0050

Notes:

HYU0018

To suit Hyundai Elantra Lavita XD
4 cyl 1.8 & 2.0L 10/2000 - 1/2004



Core Height	360mm	Core Width	620mm
Core Thickness	26mm 1 Row	Inlet / Outlet	33 / 33
Oil Cooler	400mm		
Condenser	CNX147	Receiver Drier	RDX491

Notes:

HYU1018

To suit Hyundai Elantra Lavita XD
4 cyl 1.8 & 2.0L 10/2000 - 1/2004



ALUMINIUM / PLASTIC
MANUAL

Core Height	360mm	Core Width	620mm
Core Thickness	18mm 1 Row	Inlet / Outlet	33 / 33
Oil Cooler	N/A		
Condenser	CNX147	Receiver Drier	RDX491

Notes:

HYU0019

To suit Hyundai Elantra XD
4 cyl 1.8 & 2.0L 10/2000 - 9/2006



ALUMINIUM / PLASTIC
AUTOMATIC

Core Height	375mm	Core Width	670mm
Core Thickness	19mm 1 Row	Inlet / Outlet	33 / 33
Oil Cooler	370mm		
Condenser	CNX147	Receiver Drier	RDX491

Notes:

HYU30060

To suit Hyundai Elantra XD
4 cyl 1.8 & 2.0L 10/2000 - 9/2006



ALUMINIUM / PLASTIC
AUTOMATIC

Core Height	375mm	Core Width	670mm
Core Thickness	16mm 1 Row	Inlet / Outlet	33 / 33
Oil Cooler	370mm		
Condenser	CNX147	Receiver Drier	RDX491

Notes:

15-HYU30060

To suit Hyundai Elantra XD
4 cyl 1.8 & 2.0L 10/2000 - 9/2006



ALUMINIUM / PLASTIC
AUTOMATIC

Core Height	375mm	Core Width	670mm
Core Thickness	16mm 1 Row	Inlet / Outlet	33 / 33
Oil Cooler	370mm		
Condenser	CNX147	Receiver Drier	RDX491

Notes:

HYU1004

To suit Hyundai Elantra XD
4 cyl 1.8 & 2.0L 10/2000 - 9/2006



ALUMINIUM / PLASTIC
MANUAL

Core Height	375mm	Core Width	670mm
Core Thickness	18mm 1 Row	Inlet / Outlet	33 / 33
Oil Cooler	N/A		
Condenser	CNX147	Receiver Drier	RDX491

Notes:

HYU30062

To suit Hyundai Elantra XD
4 cyl 1.8 & 2.0L 10/2000 - 9/2006



ALUMINIUM / PLASTIC
MANUAL

Core Height	375mm	Core Width	670mm
Core Thickness	16mm 1 Row	Inlet / Outlet	33 / 33
Oil Cooler	N/A		
Condenser	CNX147	Receiver Drier	RDX491

Notes:

HYU0006

To suit Hyundai Excel X3
4 cyl 1.5L 1/1994 - 5/2001



ALUMINIUM / PLASTIC
AUTOMATIC

Core Height	335mm	Core Width	600mm
Core Thickness	26mm 1 Row	Inlet / Outlet	31 / 31
Oil Cooler	400mm		
Condenser	CNX128	Receiver Drier	RDX477

Notes:

HYU1006

To suit Hyundai Excel X3
4 cyl 1.5L 1/1994 - 5/2001



ALUMINIUM / PLASTIC
MANUAL

Core Height	335mm	Core Width	600mm
Core Thickness	18mm 1 Row	Inlet / Outlet	33 / 33
Oil Cooler	N/A		
Condenser	CNX128	Receiver Drier	RDX477

Notes:

15-HYU1006

To suit Hyundai Excel X3
4 cyl 1.5L 1/1994 - 5/2001



ALUMINIUM / PLASTIC
MANUAL

Core Height	335mm	Core Width	600mm
Core Thickness	18mm 1 Row	Inlet / Outlet	33 / 33
Oil Cooler	N/A		
Condenser	CNX128	Receiver Drier	RDX477

Notes:

HYU0005

To suit Hyundai Excel X2
4 cyl 1.5L 1/1990 - 12/1995



ALUMINIUM / PLASTIC
AUTOMATIC

Core Height	335mm	Core Width	600mm
Core Thickness	26mm 1 Row	Inlet / Outlet	25 / 35
Oil Cooler	305mm		
Condenser	CNX129	Receiver Drier	RDX477

Notes:

HYU1005

To suit Hyundai Excel X2
4 cyl 1.5L 1/1990 - 12/1995



ALUMINIUM / PLASTIC
MANUAL

Core Height	335mm	Core Width	665mm
Core Thickness	16mm 1 Row	Inlet / Outlet	28 / 35
Oil Cooler	350mm		
Condenser	CNX129	Receiver Drier	RDX477

Notes:

HYU30020

To suit Hyundai Excel X1
4 cyl 1.5L 2/1986 - 12/1990

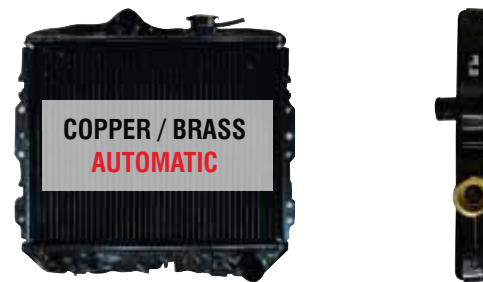

COPPER / BRASS
AUTOMATIC

Core Height	325mm	Core Width	410mm
Core Thickness	32mm 2 Row	Inlet / Outlet	36 / 39
Oil Cooler	195mm		
Condenser		Receiver Drier	RDX414

Notes:

HYU0008

To suit Hyundai Getz TB
4 cyl 1.3, 1.4, 1.5 & 1.6L 9/2002 - 10/2008



Core Height	375mm	Core Width	490mm
Core Thickness	18mm 1 Row	Inlet / Outlet	32 / 32
Oil Cooler	365mm		
Condenser	CNX125	Receiver Drier	RDX0040

Notes:

HYU1008

To suit Hyundai Getz TB
4 cyl 1.3, 1.4, 1.5 & 1.6L 9/2002 - 10/2008



Core Height	375mm	Core Width	490mm
Core Thickness	18mm 1 Row	Inlet / Outlet	33 / 33
Oil Cooler	N/A		
Condenser	CNX125	Receiver Drier	RDX0040

Notes:

HYU30070

To suit Hyundai Grandeur T41
V6 3.0L 9/1999 - 4/2003



Core Height	405mm	Core Width	715mm
Core Thickness	24mm 1 Row	Inlet / Outlet	35 / 35
Oil Cooler	380mm		
Condenser	CNX732	Receiver Drier	RDX492

Notes:

HYU0035

To suit Hyundai i30 FD
4 cyl 1.6L Turbo Diesel & 2.0L Petrol 10/2007 >



Core Height	600mm	Core Width	455mm
Core Thickness	14mm 1 Row	Inlet / Outlet	33 / 33
Oil Cooler	335mm		
Condenser	CNX122	Receiver Drier	RDX0050

Notes:

HYU1035

To suit Hyundai i30 FD
4 cyl 1.6L Turbo Diesel & 2.0L Petrol 10/2007 >



Core Height	600mm	Core Width	455mm
Core Thickness	14mm 1 Row	Inlet / Outlet	33 / 33
Oil Cooler	N/A		
Condenser	CNX122	Receiver Drier	RDX0050

Notes:

HYU1042

To suit Hyundai iLoad iMax TQ
4 cyl 2.4L Petrol 1/2008 >



Core Height	435mm	Core Width	775mm
Core Thickness	18mm 1 Row	Inlet / Outlet	35 / 35
Oil Cooler	N/A		
Condenser	CNX163	Receiver Drier	

Notes:

HYU0042

To suit Hyundai iLoad iMax TQ
4 cyl 2.4L Petrol 1/2008 >



Core Height	435mm	Core Width	775mm
Core Thickness	18mm 1 Row	Inlet / Outlet	35 / 35
Oil Cooler	400mm		
Condenser	CNX163	Receiver Drier	

Notes:

HYU1043

To suit Hyundai iLoad iMax TQ
4 cyl 2.5L Turbo Diesel 1/2008 >



Core Height	435mm	Core Width	775mm
Core Thickness	18mm 1 Row	Inlet / Outlet	35 / 35
Oil Cooler	N/A		
Condenser	CNX163	Receiver Drier	

Notes:

HYU0043

To suit Hyundai iLoad iMax TQ
4 cyl 2.5L Turbo Diesel 1/2008 >



Core Height	435mm	Core Width	775mm
Core Thickness	18mm 1 Row	Inlet / Outlet	35 / 35
Oil Cooler	400mm		
Condenser	CNX163	Receiver Drier	

Notes:

HYU0010

To suit Hyundai Lantra J2 J3
4 cyl 1.8 & 2.0L 9/1995 - 10/2000



Core Height	375mm	Core Width	665mm
Core Thickness	16mm 1 Row	Inlet / Outlet	33 / 33
Oil Cooler	350mm		
Condenser	CNX143	Receiver Drier	RDX476

Notes:

HYU1010

To suit Hyundai Lantra J2 J3
4 cyl 1.8 & 2.0L 9/1995 - 10/2000



Core Height	375mm	Core Width	665mm
Core Thickness	16mm 1 Row	Inlet / Outlet	35 / 35
Oil Cooler	N/A		
Condenser	CNX143	Receiver Drier	RDX476

Notes:

HYU0020

To suit Hyundai Lantra
4 cyl 1.8L 10/1992 - 8/1995



Core Height	370mm	Core Width	670mm
Core Thickness	18mm 1 Row	Inlet / Outlet	35 / 35
Oil Cooler	380mm		
Condenser	CNX132	Receiver Drier	RDX022

Notes: Sensor Port Bottom Tank

HYU1020

To suit Hyundai Lantra
4 cyl 1.8L 10/1992 - 8/1995



ALUMINIUM / PLASTIC
MANUAL

Core Height	370mm	Core Width	670mm
Core Thickness	16mm 1 Row	Inlet / Outlet	35 / 35
Oil Cooler	N/A		
Condenser	CNX132	Receiver Drier	RDX022

Notes: Sendor Port Bottom Tank

R11CA

To suit Hyundai Lantra G4 CN
4 cyl 1.8L 10/1992 - 8/1995



ALUMINIUM / PLASTIC
AUTOMATIC

Core Height	375mm	Core Width	669mm
Core Thickness	16mm 1 Row	Inlet / Outlet	36 / 36
Oil Cooler	350mm		
Condenser	CNX132	Receiver Drier	RDX022

Notes: 2 x Sendor

HYU1152

To suit Hyundai Santa Fe CM
V6 2.7L 5/2006>



ALUMINIUM / PLASTIC
AUTOMATIC

Core Height	435mm	Core Width	770mm
Core Thickness	18mm 1 Row	Inlet / Outlet	35 / 35
Oil Cooler	440mm		
Condenser	CNX123	Receiver Drier	

Notes:

HYU1012

To suit Hyundai Santa Fe B81
4 cyl 2.4L 1/2001 - 9/2003



ALUMINIUM / PLASTIC
MANUAL

Core Height	400mm	Core Width	725mm
Core Thickness	18mm 1 Row	Inlet / Outlet	36 / 36
Oil Cooler	N/A		
Condenser	CNX150	Receiver Drier	RDX491

Notes:

HYU30080

To suit Hyundai Santa Fe SM
V6 2.7L 11/2000 - 4/2006



ALUMINIUM / PLASTIC
AUTOMATIC

Core Height	405mm	Core Width	725mm
Core Thickness	24mm 1 Row	Inlet / Outlet	35 / 35
Oil Cooler	440mm		
Condenser	CNX150	Receiver Drier	RDX0050

Notes:

HYU0011

To suit Hyundai Santa Fe SM
V6 2.7L 11/2000 - 4/2006



ALUMINIUM / PLASTIC
AUTOMATIC

Core Height	400mm	Core Width	720mm
Core Thickness	18mm 1 Row	Inlet / Outlet	35 / 35
Oil Cooler	440mm		
Condenser	CNX150	Receiver Drier	RDX0050

Notes:

HYU0013

To suit Hyundai S Coupe
4 cyl 1.5L 7/1990 - 5/1996



ALUMINIUM / PLASTIC
AUTOMATIC

Core Height	335mm	Core Width	600mm
Core Thickness	26mm 1 Row	Inlet / Outlet	36 / 36
Oil Cooler	315mm		
Condenser	CNX129	Receiver Drier	RDX478

Notes:

R7CA

To suit Hyundai S Coupe
4 cyl 1.5L 7/1990 - 5/1996



ALUMINIUM / PLASTIC
AUTOMATIC

Core Height	335mm	Core Width	603mm
Core Thickness	25mm 1 Row	Inlet / Outlet	35 / 35
Oil Cooler	300mm		
Condenser	CNX129	Receiver Drier	RDX478

Notes:

HYU0001

To suit Hyundai Sonata NF
4 cyl 2.4L & V6 3.3L 6/2005 - 6/2008



ALUMINIUM / PLASTIC
AUTOMATIC

Core Height	640mm	Core Width	480mm
Core Thickness	16mm 1 Row	Inlet / Outlet	35 / 35
Oil Cooler	375mm		
Condenser	CNX149	Receiver Drier	RDX0050

Notes:

HYU30070

To suit Hyundai Sonata EF-B
4 cyl 2.4L & V6 2.7L 9/2001 - 6/2005



ALUMINIUM / PLASTIC
AUTOMATIC

Core Height	405mm	Core Width	715mm
Core Thickness	24mm 1 Row	Inlet / Outlet	35 / 35
Oil Cooler	380mm		
Condenser	CNX732	Receiver Drier	RDX492

Notes:

HYU30070

To suit Hyundai Sonata EF
4 cyl 2.0L & V6 2.5L 8/1998 - 9/2001



ALUMINIUM / PLASTIC
AUTOMATIC

Core Height	405mm	Core Width	715mm
Core Thickness	24mm 1 Row	Inlet / Outlet	35 / 35
Oil Cooler	380mm		
Condenser	CNX732	Receiver Drier	RDX492

Notes:

HYU0002

To suit Hyundai Sonata F21
4 cyl 2.0L 11/1993 - 8/1998



ALUMINIUM / PLASTIC
AUTOMATIC

Core Height	400mm	Core Width	680mm
Core Thickness	28mm 1 Row	Inlet / Outlet	35 / 35
Oil Cooler	380mm		
Condenser	CNX126	Receiver Drier	RDX475

Notes: 2 x Sensor Port Bottom Tank

HYU1002

To suit Hyundai Sonata F21
4 cyl 2.0L 11/1993 - 8/1998



Core Height	400mm	Core Width	675mm
Core Thickness	28mm 1 Row	Inlet / Outlet	33 / 33
Oil Cooler			
Condenser	CNX126	Receiver Drier	RDX475

Notes: Twin Sender Ports

HYU30050

To suit Hyundai Sonata F21
4 cyl 2.0 & 2.4L 3/1989 - 8/1998

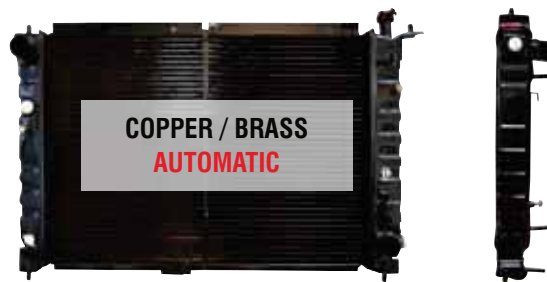

Core Height	580mm	Core Width	400mm
Core Thickness	32mm 2 Row	Inlet / Outlet	40 / 40
Oil Cooler	275mm		
Condenser	CNX130	Receiver Drier	RDX489

Notes: Open Sender

HYU1205

To suit Hyundai Terracan CRDI J3
4 cyl 2.9L Turbo Diesel 1/2005 - 1/2009



Core Height	510mm	Core Width	570mm
Core Thickness	26mm 1 Row	Inlet / Outlet	36 / 36
Oil Cooler	440mm		
Condenser	CNX168	Receiver Drier	

Notes:

HYU1206

To suit Hyundai Terracan G6CU
V6 3.5L 11/2001 - 1/2009



Core Height	510mm	Core Width	570mm
Core Thickness	34mm 2 Row	Inlet / Outlet	36 / 36
Oil Cooler	440mm		
Condenser	CNX168	Receiver Drier	

Notes:

HYU30060

To suit Hyundai Tiburon
4 cyl 2.0L 2/2002 - 5/2004



Core Height	375mm	Core Width	670mm
Core Thickness	16mm 1 Row	Inlet / Outlet	33 / 33
Oil Cooler	370mm		
Condenser	CNX147	Receiver Drier	RDX491

Notes:

15-HYU30060

To suit Hyundai Tiburon
4 cyl 2.0L 2/2002 - 5/2004



Core Height	375mm	Core Width	670mm
Core Thickness	16mm 1 Row	Inlet / Outlet	33 / 33
Oil Cooler	370mm		
Condenser	CNX147	Receiver Drier	RDX491

Notes:

HYU0016

To suit Hyundai Tiburon N61
V6 2.7L 3/2002>



ALUMINIUM / PLASTIC
AUTOMATIC

Core Height	375mm	Core Width	655mm
Core Thickness	16mm 1 Row	Inlet / Outlet	33 / 33
Oil Cooler	375mm		
Condenser	CNX147	Receiver Drier	RDX491

Notes:

HYU1016

To suit Hyundai Tiburon N61
V6 2.7L 3/2002>



ALUMINIUM / PLASTIC
MANUAL

Core Height	375mm	Core Width	660mm
Core Thickness	16mm 1 Row	Inlet / Outlet	33 / 33
Oil Cooler	N/A		
Condenser	CNX147	Receiver Drier	RDX491

Notes:

HYU0021

To suit Hyundai Trajet
V6 2.7L 7/2000 - 6/2009



ALUMINIUM / PLASTIC
AUTOMATIC

Core Height	400mm	Core Width	720mm
Core Thickness	35mm 1 Row	Inlet / Outlet	35 / 35
Oil Cooler	385mm		
Condenser	CNX735	Receiver Drier	RDX491

Notes:

HYU1510

To suit Hyundai Tucson N81 City
4 cyl 2.0L & V6 2.7L 8/2004 - 8/2008



ALUMINIUM / PLASTIC
AUTOMATIC

Core Height	640mm	Core Width	455mm
Core Thickness	16mm 1 Row	Inlet / Outlet	35 / 35
Oil Cooler	290mm		
Condenser	CNX738	Receiver Drier	RDX491

Notes:

HOL25060

To suit Isuzu MU 4JG2
4 cyl 3.1L Diesel 1/1993 - 12/1999



COPPER / BRASS
AUTOMATIC

Core Height	425mm	Core Width	615mm
Core Thickness	35mm 2 Row	Inlet / Outlet	38 / 38
Oil Cooler	365mm		
Condenser	CNX046	Receiver Drier	RDX022

Notes:

ISU1240

To suit Isuzu Truck
6 cyl 5.2L Diesel 2000 - 2004



ALUMINIUM / PLASTIC
MANUAL

Core Height	620mm	Core Width	595mm
Core Thickness	36mm 1 Row	Inlet / Outlet	38 / 38
Oil Cooler	N/A		
Condenser		Receiver Drier	RDX5810 / RDX5811

Notes:

ISU1236

To suit Isuzu Truck N Series
4 cyl 3.0L Diesel 2000 >



Core Height	510mm	Core Width	465mm
Core Thickness	32mm 1 Row	Inlet / Outlet	38 / 38
Oil Cooler	N/A		
Condenser		Receiver Drier	RDX5810 / RDX5811

Notes:

ISU1239

To suit Isuzu NPR
6 cyl 5.2L Diesel 2000 >



Core Height	510mm	Core Width	462mm
Core Thickness	32mm 1 Row	Inlet / Outlet	38 / 38
Oil Cooler	N/A		
Condenser		Receiver Drier	RDX5810 / RDX5811

Notes:

ISU1237

To suit Isuzu Truck N Series
4 cyl 3.0L Diesel 1999 - 2002



Core Height	510mm	Core Width	466mm
Core Thickness	32mm 1 Row	Inlet / Outlet	38 / 38
Oil Cooler	N/A		
Condenser		Receiver Drier	RDX5810 / RDX5811

Notes:

ISU1124

To suit Isuzu Truck NPR
4 cyl 3.0L Diesel 1999 >



Core Height	580mm	Core Width	535mm
Core Thickness	36mm 1 Row	Inlet / Outlet	38 / 38
Oil Cooler	N/A		
Condenser		Receiver Drier	RDX5810 / RDX5811

Notes:

IVE17551

To suit Iveco Daily
4 cyl 2.3L Turbo Diesel 5/2005 - 4/2007



Core Height	625mm	Core Width	460mm
Core Thickness	32mm 2 Row	Inlet / Outlet	38 / 38
Oil Cooler	N/A		
Condenser	CNX454	Receiver Drier	

Notes:

IVE74431

To suit Iveco Daily
4 cyl 2.3, 2.8 & 3.0L Turbo Diesel
1/2002 - 12/2007



Core Height	650mm	Core Width	456mm
Core Thickness	37mm 2 Row	Inlet / Outlet	38 / 36
Oil Cooler	N/A		
Condenser	CNX454	Receiver Drier	

Notes:

IVE24561**To suit Iveco Daily**

4 cyl 2.8L Turbo Diesel 1/1998 - 1/2003



Core Height	650mm	Core Width	440mm
Core Thickness	27mm 1 Row	Inlet / Outlet	38 / 38
Oil Cooler	N/A		
Condenser		Receiver Drier	

Notes: M22 x 1.5 Switch Port. 8mm Bleeder Pipe

IVE24501**To suit Iveco Daily SI**

4 cyl 2.8L 1991 - 2006



Core Height	625mm	Core Width	375mm
Core Thickness	36mm 1 Row	Inlet / Outlet	38 / 38
Oil Cooler	N/A		
Condenser		Receiver Drier	

Notes: M22 x 1.5 Switch Port. 8mm Bleeder Pipe

IVE04611**To suit Iveco Eurocargo ML Series**4 & 6 cyl 3.9L & 5.9L Turbo Diesel
11/1998 - 12/2008

Core Height	542mm	Core Width	568mm
Core Thickness	42mm	Inlet / Outlet	45 / 45
Oil Cooler	N/A		
Condenser	CNX455	Receiver Drier	

Notes:

IVE58001**To suit Iveco Eurocargo ML Series**4 cyl 3.9L & 6 cyl 5.9L Turbo Diesel
11/1998 - 12/2008

Core Height	640mm	Core Width	568mm
Core Thickness	42mm	Inlet / Outlet	45 / 45
Oil Cooler	N/A		
Condenser	CNX455	Receiver Drier	

Notes:

IVE05761**To suit Iveco Eurocargo 170E**

1992 >



Core Height	625mm	Core Width	608mm
Core Thickness	42mm	Inlet / Outlet	
Oil Cooler	N/A		
Condenser		Receiver Drier	

Notes: 8mm Bleed Pipe top left tank

IVE21581**To suit Iveco Eurostar**6 cyl 9.5, 13.8 & 17.2L Turbo Diesel
1/1996 - 1/2002

Core Height	900mm	Core Width	745mm
Core Thickness	45mm 1 Row	Inlet / Outlet	60 / 60
Oil Cooler	N/A		
Condenser	CNX453	Receiver Drier	

Notes:

IVE21611

To suit Iveco Eurotech
6 cyl 7.8L Turbo Diesel 1/2004 - 1/2008



Core Height	800mm	Core Width	748mm
Core Thickness	42mm 1 Row	Inlet / Outlet	60 / 60
Oil Cooler	N/A		
Condenser		Receiver Drier	

Notes:

IVE21601

To suit Iveco Eurotech
6 cyl 13.8L Turbo Diesel 1/1997 - 12/2000



Core Height	900mm	Core Width	748mm
Core Thickness	42mm 1 Row	Inlet / Outlet	60 / 60
Oil Cooler	N/A		
Condenser		Receiver Drier	

Notes:

IVE21741

To suit Iveco Stralis Cursor
6 cyl 10.3 & 12.9L Turbo Diesel 3/2005 >



Core Height	1125mm	Core Width	750mm
Core Thickness	42mm 2 Row	Inlet / Outlet	56 / 56
Oil Cooler	N/A		
Condenser		Receiver Drier	

Notes:

IVE21791

To suit Iveco Stralis Cursor 10
405 - 4350hp 6 cyl 10.3L Diesel 2003 >



Core Height	900mm	Core Width	750mm
Core Thickness	42mm 1 Row	Inlet / Outlet	56 / 56
Oil Cooler	N/A		
Condenser		Receiver Drier	

Notes:

JAG64141

To suit Jaguar X-Type X400
V6 2.1, 2.5 & 3.0L 1/2001 - 11/2004



Core Height	620mm	Core Width	433mm
Core Thickness	26mm 1 Row	Inlet / Outlet	34 / 34
Oil Cooler	N/A		
Condenser		Receiver Drier	

Notes: Clip on Bottom Pipe

JAG64041

To suit Jaguar XK8 Classic
V8 4.0L 11/1996 - 10/2002



Core Height	665mm	Core Width	440mm
Core Thickness	26mm 1 Row	Inlet / Outlet	42 / 42
Oil Cooler	305mm		
Condenser		Receiver Drier	RDX147

Notes:

JEE31136

To suit Jeep Cherokee KJ
6 cyl 3.7L 9/2001 - 3/2008



Core Height	510mm	Core Width	510mm
Core Thickness	32mm 1 Row	Inlet / Outlet	39 / 48
Oil Cooler	300mm		
Condenser		Receiver Drier	RDX588

Notes:

JEE31120

To suit Jeep Cherokee XJ
6 cyl 4.0L & 2.5L Turbo Diesel
4/1994 - 12/2001



Core Height	790mm	Core Width	280mm
Core Thickness	45mm 3 Row	Inlet / Outlet	33 / 39
Oil Cooler	195mm		
Condenser	CNX670	Receiver Drier	RDX585

Notes: Oil Cooler on Passenger side

JEE31127

To suit Jeep Cherokee XJ
6 cyl 4.0L 4/1994 - 12/2001



Core Height	787mm	Core Width	278mm
Core Thickness	32mm 1 Row	Inlet / Outlet	32 / 38
Oil Cooler	190mm		
Condenser	CNX670	Receiver Drier	RDX585

Notes: Oil Cooler on Drivers side

JEE31125

To suit Jeep Cherokee XJ
6 cyl 4.0L 4/1994 - 12/2001



Core Height	787mm	Core Width	278mm
Core Thickness	30mm 2 Row	Inlet / Outlet	32 / 38
Oil Cooler	190mm		
Condenser	CNX670	Receiver Drier	RDX585

Notes: Oil Cooler on Drivers side

JEE31144

To suit Jeep Cherokee XJ
6 cyl 4.0L 4/1994 - 12/2001



Core Height	590mm	Core Width	515mm
Core Thickness	32mm 1 Row	Inlet / Outlet	39 / 46
Oil Cooler	N/A		
Condenser	CNX670	Receiver Drier	RDX585

Notes: External Oil Cooler

JEE31140

To suit Jeep Grand Cherokee WG
V8 4.7L 1/2001 - 6/2005



Core Height	600mm	Core Width	505mm
Core Thickness	24mm 1 Row	Inlet / Outlet	38 / 38
Oil Cooler	300mm		
Condenser	CNX282	Receiver Drier	

Notes:

JEE31138

To suit Jeep Grand Cherokee WG WJ
6 cyl 4.0L 6/1999 - 6/2005



Core Height	595mm	Core Width	556mm
Core Thickness	24mm 1 Row	Inlet / Outlet	38 / 38
Oil Cooler	305mm		
Condenser	CNX282	Receiver Drier	

Notes:

JEE31125

To suit Jeep Grand Cherokee WJ
6 cyl 4.0L 6/1999 - 1/2001



Core Height	787mm	Core Width	278mm
Core Thickness	30mm 2 Row	Inlet / Outlet	32 / 38
Oil Cooler	190mm		
Condenser	CNX670	Receiver Drier	RDX585

Notes: Oil Cooler on Drivers side

JEE31144

To suit Jeep Grand Cherokee WJ
V8 4.7L 6/1999 - 1/2001



Core Height	590mm	Core Width	515mm
Core Thickness	32mm 1 Row	Inlet / Outlet	39 / 46
Oil Cooler	N/A		
Condenser	CNX282	Receiver Drier	

Notes: External Oil Cooler

JEE31131

To suit Jeep Grand Cherokee ZG
6 cyl 4.0L 3/1996 - 7/1999



Core Height	565mm	Core Width	498mm
Core Thickness	32mm 1 Row	Inlet / Outlet	32 / 38
Oil Cooler	305mm		
Condenser	CNX671	Receiver Drier	RDX586

Notes:

JEE31130

To suit Jeep Grand Cherokee ZG
6 cyl 4.0L 3/1996 - 7/1999

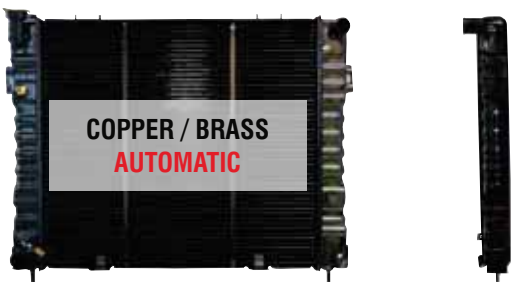

Core Height	565mm	Core Width	500mm
Core Thickness	45mm 3 Row	Inlet / Outlet	33 / 39
Oil Cooler	300mm		
Condenser	CNX671	Receiver Drier	RDX586

Notes:

JEE31132

To suit Jeep Wrangler TJ
6 cyl 4.0L 1992 - 1996



Core Height	455mm	Core Width	490mm
Core Thickness	32mm 1 Row	Inlet / Outlet	32 / 38
Oil Cooler	305mm		
Condenser		Receiver Drier	

Notes:

JOD10011

To suit John Deere 6 Series 6100 - 6900
1992 - 1998



Core Height	516mm	Core Width	503mm
Core Thickness	77mm 4 Row	Inlet / Outlet	60 / 60
Oil Cooler	N/A	Receiver Drier	RDX510
Condenser		Receiver Drier	RDX679

Notes:

JOD10051

To suit John Deere 6 Series 6100 - 6900
1992 - 1998



Core Height	516mm	Core Width	503mm
Core Thickness	57mm 4 Row	Inlet / Outlet	60 / 60
Oil Cooler	N/A	Receiver Drier	RDX510
Condenser		Receiver Drier	RDX679

Notes:

JOD10021

To suit John Deere 6 Series 6500 - 6800



Core Height	575mm	Core Width	490mm
Core Thickness	78mm 2 Row	Inlet / Outlet	60 / 60
Oil Cooler	N/A		
Condenser		Receiver Drier	RDX510

Notes:

KIA0001

To suit Kia Carens TB
4 cyl 1.8L 7/2000 - 10/2002



Core Height	345mm	Core Width	680mm
Core Thickness	28mm 2 Row	Inlet / Outlet	33 / 33
Oil Cooler	350mm		
Condenser		Receiver Drier	

Notes:

R33CM

To suit Kia Carens TB
4 cyl 1.8L 7/2000 - 10/2002



Core Height	430mm	Core Width	670mm
Core Thickness	27mm 1 Row	Inlet / Outlet	33 / 33
Oil Cooler	N/A		
Condenser		Receiver Drier	

Notes:

KIA0003

To suit Kia Carnival KV SI & II KV6
V6 2.5L 9/1999 - 12/2006



Core Height	700mm	Core Width	420mm
Core Thickness	28mm 1 Row	Inlet / Outlet	36 / 36
Oil Cooler	295mm		
Condenser	CNX733	Receiver Drier	

Notes:

KIA1003

To suit Kia Carnival KV SI & II KV6
V6 2.5L 9/1999 - 12/2006



ALUMINIUM / PLASTIC
MANUAL

Core Height	700mm	Core Width	420mm
Core Thickness	28mm 1 Row	Inlet / Outlet	36 / 36
Oil Cooler	N/A		
Condenser	CNX733	Receiver Drier	

Notes:

KIA1153

To suit Kia Cerato
4 cyl 2.0L 4/2006 - 1/2009



ALUMINIUM / PLASTIC
AUTOMATIC

Core Height	375mm	Core Width	665mm
Core Thickness	18mm 1 Row	Inlet / Outlet	34 / 34
Oil Cooler	375mm		
Condenser	CNX739	Receiver Drier	

Notes:

KIA0013

To suit Kia Cremos G11 FE
4 cyl 2.0L 5/1998 - 5/2001



ALUMINIUM / PLASTIC
AUTOMATIC

Core Height	690mm	Core Width	390mm
Core Thickness	26mm 1 Row	Inlet / Outlet	35 / 35
Oil Cooler	245mm		
Condenser		Receiver Drier	

Notes:

KIA1699

To suit Kia Cremos G11 FE
4 cyl 2.0L 5/1998 - 5/2001



ALUMINIUM / PLASTIC
MANUAL

Core Height	690mm	Core Width	390mm
Core Thickness	26mm 2 Row	Inlet / Outlet	36 / 36
Oil Cooler	N/A		
Condenser		Receiver Drier	

Notes:

HYU0001

To suit Kia Magentis LX MG
4 cyl 2.4 & V6 2.7L 9/2006 - 10/2009



ALUMINIUM / PLASTIC
AUTOMATIC

Core Height	640mm	Core Width	480mm
Core Thickness	14mm 1 Row	Inlet / Outlet	35 / 35
Oil Cooler	375mm		
Condenser	CNX149	Receiver Drier	RDX0050

Notes:

KIA0002

To suit Kia Mentor BF
4 cyl 1.5 & 1.8L 4/1998 - 4/2001



ALUMINIUM / PLASTIC
AUTOMATIC

Core Height	345mm	Core Width	700mm
Core Thickness	18mm 1 Row	Inlet / Outlet	33 / 33
Oil Cooler	375mm		
Condenser	CNX725	Receiver Drier	

Notes:

KIA0001

To suit Kia Mentor BF
4 cyl 1.5 & 1.8L 4/1998 - 4/2001

OEX

Core Height	345mm	Core Width	680mm
Core Thickness	28mm 2 Row	Inlet / Outlet	33 / 33
Oil Cooler	350mm		
Condenser	CNX725	Receiver Drier	

Notes:

KIA1002

To suit Kia Mentor BF
4 cyl 1.5 & 1.8L 4/1998 - 4/2001

OEX

Core Height	345mm	Core Width	700mm
Core Thickness	18mm 1 Row	Inlet / Outlet	33 / 33
Oil Cooler	N/A		
Condenser	CNX725	Receiver Drier	

Notes:

KIA0004

To suit Kia Mentor B5
4 cyl 1.5L 11/1996 - 4/1999

OEX

Core Height	375mm	Core Width	645mm
Core Thickness	18mm 1 Row	Inlet / Outlet	32 / 32
Oil Cooler	275mm		
Condenser	CNX726	Receiver Drier	

Notes:

KIA1004

To suit Kia Mentor B5
4 cyl 1.5L 11/1996 - 4/1999

OEX

Core Height	375mm	Core Width	645mm
Core Thickness	18mm 1 Row	Inlet / Outlet	32 / 32
Oil Cooler	N/A		
Condenser	CNX726	Receiver Drier	

Notes:

HYU30070

To suit Kia Optima GD22
V6 2.5 & 2.7L 5/2001 - 1/2007

OEX

Core Height	405mm	Core Width	715mm
Core Thickness	24mm 1 Row	Inlet / Outlet	35 / 35
Oil Cooler	380mm		
Condenser	CNX732	Receiver Drier	RDX492

Notes:

KIA0007

To suit Kia Pregio
4 cyl 2.7L Diesel 7/2002 - 3/2007

OEX

Core Height	400mm	Core Width	540mm
Core Thickness	33mm 1 Row	Inlet / Outlet	36 / 36
Oil Cooler	300mm		
Condenser		Receiver Drier	

Notes:

KIA1007

To suit Kia Pregio
4 cyl 2.7L Diesel 7/2002 - 3/2007



Core Height	400mm	Core Width	540mm
Core Thickness	33mm 1 Row	Inlet / Outlet	36 / 36
Oil Cooler	N/A		
Condenser		Receiver Drier	RDX311

Notes:

HYU0034

To suit Kia Rio JB
4 cyl 1.6L 8/2005 >



Core Height	370mm	Core Width	650mm
Core Thickness	26mm 1 Row	Inlet / Outlet	33 / 33
Oil Cooler	N/A		
Condenser	CNX722	Receiver Drier	RDX0040

Notes:

HYU1034

To suit Kia Rio JB
4 cyl 1.6L 8/2005 >



Core Height	370mm	Core Width	650mm
Core Thickness	16mm 1 Row	Inlet / Outlet	33 / 33
Oil Cooler	N/A		
Condenser	CNX722	Receiver Drier	

Notes:

KIA0006

To suit Kia Rio
4 cyl 1.5L 1/2003 - 1/2005



Core Height	350mm	Core Width	645mm
Core Thickness	16mm 1 Row	Inlet / Outlet	31 / 31
Oil Cooler	400mm		
Condenser	CNX736	Receiver Drier	RDX491

Notes:

KIA1006

To suit Kia Rio
4 cyl 1.5L 1/2003 - 1/2005



Core Height	350mm	Core Width	645mm
Core Thickness	16mm 1 Row	Inlet / Outlet	31 / 31
Oil Cooler	N/A		
Condenser	CNX736	Receiver Drier	RDX491

Notes:

KIA0005

To suit Kia Rio BC
4 cyl 1.5L 7/2000 - 12/2005



Core Height	350mm	Core Width	645mm
Core Thickness	25mm 1 Row	Inlet / Outlet	31 / 31
Oil Cooler	380mm		
Condenser	CNX731	Receiver Drier	

Notes:

KIA1005

To suit Kia Rio BC
4 cyl 1.5L 7/2000 - 12/2005

OEX

Core Height	350mm	Core Width	645mm
Core Thickness	16mm 1 Row	Inlet / Outlet	32 / 32
Oil Cooler	N/A		
Condenser	CNX731	Receiver Drier	

Notes:

KIA0002

To suit Kia Shuma TE
4 cyl 1.8L 4/2000 - 5/2002

OEX

Core Height	345mm	Core Width	700mm
Core Thickness	18mm 1 Row	Inlet / Outlet	33 / 33
Oil Cooler	375mm		
Condenser	CNX725	Receiver Drier	

Notes:

KIA0001

To suit Kia Shuma TE
4 cyl 1.8L 4/2000 - 5/2002

OEX

Core Height	345mm	Core Width	680mm
Core Thickness	28mm 2 Row	Inlet / Outlet	33 / 33
Oil Cooler	350mm		
Condenser	CNX737	Receiver Drier	RDX653

Notes:

KIA1002

To suit Kia Shuma TE
4 cyl 1.8L 4/2000 - 5/2002

OEX

Core Height	345mm	Core Width	700mm
Core Thickness	18mm 1 Row	Inlet / Outlet	33 / 33
Oil Cooler	N/A		
Condenser	CNX725	Receiver Drier	

Notes:

KIA0011

To suit Kia Sorento BL
4 cyl 2.5L Turbo Diesel 8/2007 - 12/2009

OEX

Core Height	474mm	Core Width	640mm
Core Thickness	26mm 1 Row	Inlet / Outlet	35 / 35
Oil Cooler	380mm		
Condenser		Receiver Drier	

Notes:

KIA1203

To suit Kia Sorento BL
V6 3.5L 2/2003 - 10/2004

OEX

Core Height	575mm	Core Width	640mm
Core Thickness	26mm 1 Row	Inlet / Outlet	35 / 35
Oil Cooler	380mm		
Condenser	CNX167	Receiver Drier	

Notes:

KIA0002

To suit Kia Spectra TE
cyl 1.8L 5/2001 - 11/2004



Core Height	345mm	Core Width	700mm
Core Thickness	18mm 1 Row	Inlet / Outlet	33 / 33
Oil Cooler	375mm		
Condenser	CNX725	Receiver Drier	

Notes:

KIA0001

To suit Kia Spectra TE
4 cyl 1.8L 5/2001 - 11/2004



Core Height	345mm	Core Width	680mm
Core Thickness	28mm 2 Row	Inlet / Outlet	33 / 33
Oil Cooler	350mm		
Condenser	CNX737	Receiver Drier	RDX653

Notes:

KIA1002

To suit Kia Spectra TE
4 cyl 1.8L 5/2001 - 11/2004



Core Height	345mm	Core Width	700mm
Core Thickness	18mm 1 Row	Inlet / Outlet	33 / 33
Oil Cooler	N/A		
Condenser	CNX725	Receiver Drier	

Notes:

KIA0012

To suit Kia Sportage FE
4 cyl 2.0L 4/2000 - 7/2003

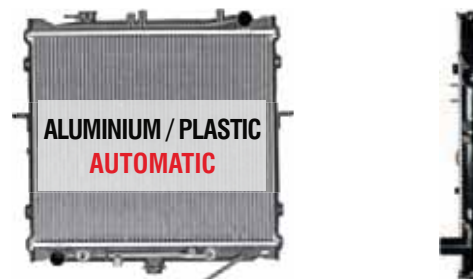

Core Height	455mm	Core Width	515mm
Core Thickness	26mm 1 Row	Inlet / Outlet	36 / 36
Oil Cooler	275mm		
Condenser	CNX730	Receiver Drier	RDX461

Notes:

KIA1012

To suit Kia Sportage FE
4 cyl 2.0L 4/2000 - 7/2003



Core Height	450mm	Core Width	520mm
Core Thickness	26mm 1 Row	Inlet / Outlet	36 / 36
Oil Cooler	N/A		
Condenser	CNX730	Receiver Drier	RDX461

Notes:

ROV45721

To suit Land Rover Range Rover 111 LM
4.2L 5/2005 >



Core Height	628mm	Core Width	608mm
Core Thickness	40mm 1 Row	Inlet / Outlet	35 / 38
Oil Cooler	N/A		
Condenser		Receiver Drier	

Notes: Bleeder Pipe

ROV18321

To suit Land Rover Range Rover
V8 4.4L 8/2002 >



Core Height	608mm	Core Width	628mm
Core Thickness	40mm 1 Row	Inlet / Outlet	38 / 38
Oil Cooler	N/A		
Condenser		Receiver Drier	

Notes:

TOY60270

To suit Lexus ES300 MCV20 30R
V6 3.0L 10/1996 - 11/2005



Core Height	400mm	Core Width	740mm
Core Thickness	24mm 1 Row	Inlet / Outlet	34 / 34
Oil Cooler	375mm		
Condenser	CNX809	Receiver Drier	RDX281

Notes:

E32CA

To suit Lexus ES300 MCV20R
V6 3.0L 10/1996 - 11/2005



Core Height	399mm	Core Width	737mm
Core Thickness	27mm 2 Row	Inlet / Outlet	35 / 35
Oil Cooler	375mm		
Condenser	CNX809	Receiver Drier	RDX281

Notes:

E70CA

To suit Lexus ES300 VCV10R
V6 3.0L 6/1992 - 10/1996



Core Height	424mm	Core Width	718mm
Core Thickness	27mm 1 Row	Inlet / Outlet	35 / 35
Oil Cooler	375mm		
Condenser	CNX809	Receiver Drier	RDX281

Notes:

TOY60070

To suit Lexus ES300 VCV10R
V6 3.0L 6/1992 - 10/1996



Core Height	424mm	Core Width	718mm
Core Thickness	24mm 1 Row	Inlet / Outlet	35 / 35
Oil Cooler	375mm		
Condenser	CNX1580	Receiver Drier	RDX281

Notes:

E71CA

To suit Lexus GS300
6 cyl 3.0L 10/1997 - 3/2005



Core Height	400mm	Core Width	756mm
Core Thickness	16mm 1 Row	Inlet / Outlet	35 / 41
Oil Cooler	375mm		
Condenser	CNX8400	Receiver Drier	RDX0070

Notes:

E80CA

To suit Lexus IS200 GXE10R
6 cyl 2.0L 3/1999 - 11/2005



ALUMINIUM / PLASTIC
AUTOMATIC

Core Height	374mm	Core Width	716mm
Core Thickness	16mm 1 Row	Inlet / Outlet	35 / 35
Oil Cooler	375mm		
Condenser	CNX0240	Receiver Drier	RDX0050

Notes:

E80CM

To suit Lexus IS200 GXE10R
6 cyl 2.0L 3/1999 - 11/2005



ALUMINIUM / PLASTIC
MANUAL

Core Height	375mm	Core Width	718mm
Core Thickness	16mm 1 Row	Inlet / Outlet	34 / 34
Oil Cooler	N/A		
Condenser	CNX0240	Receiver Drier	RDX0050

Notes:

E116CM

To suit Lexus IS250 BK
V6 2.5L 11/2005 >



ALUMINIUM / PLASTIC
AUTOMATIC & MANUAL

Core Height	375mm	Core Width	710mm
Core Thickness	16mm 1 Row	Inlet / Outlet	38 / 38
Oil Cooler	N/A		
Condenser	CNX1122	Receiver Drier	RDX0040

Notes: External Oil Cooler

E81CA

To suit Lexus IS300 JCE10R
6 cyl 3.0L 8/2001 - 11/2005



ALUMINIUM / PLASTIC
AUTOMATIC

Core Height	375mm	Core Width	716mm
Core Thickness	28mm 1 Row	Inlet / Outlet	35 / 35
Oil Cooler	375mm		
Condenser	CNX0240	Receiver Drier	RDX0050

Notes:

E109CA

To suit Lexus LS430 UCF30R
V8 4.3L 11/2000 - 5/2008



ALUMINIUM / PLASTIC
AUTOMATIC

Core Height	424mm	Core Width	756mm
Core Thickness	27mm 1 Row	Inlet / Outlet	38 / 38
Oil Cooler	380mm		
Condenser	CNX8360	Receiver Drier	RDX0070

Notes:

TOY61260

To suit Lexus LX470 UZJ100R
V8 4.7L Petrol 4/1998 - 4/2008



ALUMINIUM / PLASTIC
AUTOMATIC

Core Height	510mm	Core Width	705mm
Core Thickness	52mm 2 Row	Inlet / Outlet	38 / 42
Oil Cooler	390mm		
Condenser	CNX0861	Receiver Drier	RDX0020

Notes:

E44CA

To suit Lexus LS400 UCF10R UCF20R
V8 4.0L 1/1990 - 11/2000



ALUMINIUM / PLASTIC
AUTOMATIC

Core Height	400mm	Core Width	747mm
Core Thickness	32mm 2 Row	Inlet / Outlet	41 / 41
Oil Cooler	375mm		
Condenser		Receiver Drier	

Notes:

E120CA

To suit Lexus RX330 MCU38R
V6 3.3L 4/2003 - 2/2006



ALUMINIUM / PLASTIC
AUTOMATIC

Core Height	670mm	Core Width	495mm
Core Thickness	22mm 1 Row	Inlet / Outlet	34 / 38
Oil Cooler	350mm		
Condenser	CNX8380	Receiver Drier	RDX0070

Notes:

E102CA

To suit Lexus RX330 MCU38R
V6 3.3L 4/2003 - 2/2006



ALUMINIUM / PLASTIC
AUTOMATIC

Core Height	670mm	Core Width	491mm
Core Thickness	22mm 1 Row	Inlet / Outlet	34 / 38
Oil Cooler	350mm		
Condenser	CNX8380	Receiver Drier	RDX0070

Notes:

E126CA

To suit Lexus RX350 GGL15R & GS435R
V6 3.5L 1/2006 >



ALUMINIUM / PLASTIC
AUTOMATIC

Core Height	675mm	Core Width	478mm
Core Thickness	22mm 1 Row	Inlet / Outlet	35 / 38
Oil Cooler	350mm		
Condenser	CNX1271	Receiver Drier	RDX0070

Notes:

E88CA

To suit Lexus SC430 N48
V8 4.3L 10/2001 >



ALUMINIUM / PLASTIC
AUTOMATIC

Core Height	400mm	Core Width	755mm
Core Thickness	26mm 1 Row	Inlet / Outlet	38 / 38
Oil Cooler	375mm		
Condenser	CNX3020	Receiver Drier	

Notes:

MAC26481

To suit Mack Premium 320 36V
6 cyl 11.1L Turbo Diesel 1/2003 >



ALUMINIUM / PLASTIC
AUTOMATIC & MANUAL

Core Height	915mm	Core Width	727mm
Core Thickness	52mm 3 Row	Inlet / Outlet	50 / 50
Oil Cooler	N/A		
Condenser		Receiver Drier	

Notes: 8mm Bleed Pipe top left tank

MAC21781

To suit Mack Premium 36V
6 cyl 6.2 & 11L inc Turbo 1/1997 >



Core Height	810mm	Core Width	708mm
Core Thickness	52mm 3 Row	Inlet / Outlet	50 / 50
Oil Cooler	N/A		
Condenser		Receiver Drier	

Notes:

MAC53551

To suit Mack Vision EA7-370
6 cyl 12.0L Turbo Diesel 1/2003 >



Core Height	810mm	Core Width	730mm
Core Thickness	52mm 1 Row	Inlet / Outlet	50 / 50
Oil Cooler	N/A		
Condenser		Receiver Drier	

Notes:

MAN22411

To suit Man Bus
Gas Powered 2006 >



Core Height	940mm	Core Width	690mm
Core Thickness	42mm 1 Row	Inlet / Outlet	50 / 50
Oil Cooler	N/A		
Condenser		Receiver Drier	

Notes:

MAN30621

To suit Man Bus TGL TGM
2005 >



Core Height	710mm	Core Width	610mm
Core Thickness	40mm 1 Row	Inlet / Outlet	50 / 50
Oil Cooler	N/A		
Condenser		Receiver Drier	

Notes:

MAN74441

To suit Man Bus M2000L
2000 >



Core Height	618mm	Core Width	590mm
Core Thickness	55mm	Inlet / Outlet	52 / 52
Oil Cooler	N/A		
Condenser		Receiver Drier	

Notes:

MAN22241

To suit Man Bus
NG - NU 9/1996 >



Core Height	810mm	Core Width	708mm
Core Thickness	52mm	Inlet / Outlet	48 / 48
Oil Cooler	N/A		
Condenser		Receiver Drier	

Notes:

MAN21461

To suit Man F2000 Truck
1994 >



Core Height	1065mm	Core Width	708mm
Core Thickness	44mm 1 Row	Inlet / Outlet	60 / 60
Oil Cooler	N/A		
Condenser		Receiver Drier	

Notes:

MAN21711

To suit Man TGA
10.5 & 12.4L 2000 >



Core Height	765mm	Core Width	938mm
Core Thickness	42mm	Inlet / Outlet	60 / 60
Oil Cooler	N/A		
Condenser		Receiver Drier	

Notes:

G10CA

To suit Mazda 121 B3 B5 Metro
4 cyl 1.3 & 1.5L 1/1994 - 12/2002



Core Height	350mm	Core Width	380mm
Core Thickness	26mm 1 Row	Inlet / Outlet	29 / 29
Oil Cooler	275mm		
Condenser	CNX010	Receiver Drier	RDX283

Notes:

G10CM

To suit Mazda 121 B3 B5 Metro
4 cyl 1.3 & 1.5L 1/1994 - 12/2002



Core Height	350mm	Core Width	380mm
Core Thickness	26mm 1 Row	Inlet / Outlet	29 / 29
Oil Cooler	N/A		
Condenser	CNX010	Receiver Drier	RDX283

Notes:

G8CA

To suit Mazda 121 B3 B5 Metro
4 cyl 1.3 & 1.5L 1/1994 - 12/2002



Core Height	349mm	Core Width	380mm
Core Thickness	27mm 1 Row	Inlet / Outlet	28 / 28
Oil Cooler	275mm		
Condenser	CNX010	Receiver Drier	RDX283

Notes:

G8CM

To suit Mazda 121 B3 B5 Metro
4 cyl 1.3 & 1.5L 1/1994 - 12/2002



Core Height	350mm	Core Width	383mm
Core Thickness	27mm 2 Row	Inlet / Outlet	29 / 29
Oil Cooler	N/A		
Condenser	CNX010	Receiver Drier	RDX283

Notes:

M35CA

To suit Mazda 121 DB - DW Metro
4 cyl 1.3 & 1.5L 11/1990 - 12/2002



Core Height	350mm	Core Width	641mm
Core Thickness	16mm 1 Row	Inlet / Outlet	29 / 33
Oil Cooler	275mm		
Condenser	CNX010	Receiver Drier	RDX283

Notes:

M36CA

To suit Mazda 121 DB - DW Metro
4 cyl 1.3 & 1.5L 11/1990 - 12/2002



Core Height	320mm	Core Width	382mm
Core Thickness	25mm 1 Row	Inlet / Outlet	29 / 29
Oil Cooler	200mm		
Condenser		Receiver Drier	RDX600

Notes:

M36CM

To suit Mazda 121 DB - DW Metro
4 cyl 1.3 & 1.5L 11/1990 - 12/2002



Core Height	320mm	Core Width	382mm
Core Thickness	16mm 1 Row	Inlet / Outlet	29 / 29
Oil Cooler	N/A		
Condenser		Receiver Drier	RDX600

Notes: Sendor Port in Bottom Tank. No Plug

G27CM

To suit Mazda 2
4 cyl 1.5L 2007 >



Core Height	350mm	Core Width	555mm
Core Thickness	16mm 1 Row	Inlet / Outlet	28 / 28
Oil Cooler	N/A		
Condenser		Receiver Drier	

Notes:

G26CA

To suit Mazda 2 DE, NEO, MAXX
4 cyl 1.5L 9/2007 >



Core Height	350mm	Core Width	555mm
Core Thickness	16mm 1 Row	Inlet / Outlet	28 / 28
Oil Cooler	275mm		
Condenser		Receiver Drier	

Notes:

G26CM

To suit Mazda 2 DE, NEO, MAXX
4 cyl 1.5L 9/2007 >



Core Height	350mm	Core Width	555mm
Core Thickness	16mm 1 Row	Inlet / Outlet	28 / 28
Oil Cooler	N/A		
Condenser		Receiver Drier	

Notes:

MAZ40162

To suit Mazda 2 DE, NEO, MAXX
4 cyl 1.5L 9/2007 >



ALUMINIUM / PLASTIC
AUTOMATIC

Core Height	350mm	Core Width	555mm
Core Thickness	24mm 1 Row	Inlet / Outlet	28 / 28
Oil Cooler	275mm		
Condenser		Receiver Drier	

Notes:

MAZ40163

To suit Mazda 2 DE, NEO, MAXX
4 cyl 1.5L 9/2007 >



ALUMINIUM / PLASTIC
MANUAL

Core Height	350mm	Core Width	555mm
Core Thickness	24mm 1 Row	Inlet / Outlet	28 / 28
Oil Cooler	N/A		
Condenser		Receiver Drier	

Notes:

G17CA

To suit Mazda 2 DY
4 cyl 1.5L 12/2002 - 9/2007



ALUMINIUM / PLASTIC
AUTOMATIC

Core Height	324mm	Core Width	536mm
Core Thickness	16mm 1 Row	Inlet / Outlet	28 / 28
Oil Cooler	275mm		
Condenser	CNX114	Receiver Drier	

Notes:

G18CM

To suit Mazda 2 DY
4 cyl 1.5L 12/2002 - 9/2007



ALUMINIUM / PLASTIC
MANUAL

Core Height	325mm	Core Width	536mm
Core Thickness	16mm 1 Row	Inlet / Outlet	28 / 28
Oil Cooler	N/A		
Condenser	CNX114	Receiver Drier	

Notes:

MAZ40160

To suit Mazda 3 BK
4 cyl 2.0 & 2.3L 1/2004 - 4/2010



ALUMINIUM / PLASTIC
AUTOMATIC & MANUAL

Core Height	670mm	Core Width	365mm
Core Thickness	16mm 1 Row	Inlet / Outlet	33 / 33
Oil Cooler	N/A		
Condenser	CNX112	Receiver Drier	RDX280

Notes: External Oil Cooler

M41CM

To suit Mazda 323 Astina BJ
4 cyl 1.6, 1.8 & 2.0L 2/1999 - 10/2002



ALUMINIUM / PLASTIC
MANUAL

Core Height	325mm	Core Width	680mm
Core Thickness	16mm 1 Row	Inlet / Outlet	29 / 29
Oil Cooler	N/A		
Condenser	CNX759	Receiver Drier	RDX182

Notes:

MAZ40144

To suit Mazda 323 Astina BJ
4 cyl 1.6 & 1.8L 1/1998 - 3/2004



ALUMINIUM / PLASTIC
MANUAL

Core Height	330mm	Core Width	688mm
Core Thickness	16mm 1 Row	Inlet / Outlet	28 / 28
Oil Cooler	N/A		
Condenser	CNX011	Receiver Drier	RDX612

Notes:

FOR40065

To suit Mazda 323 Astina BA - BJ
4 cyl 1.6 & 1.8L 8/1994 - 3/2004



ALUMINIUM / PLASTIC
AUTOMATIC

Core Height	330mm	Core Width	690mm
Core Thickness	24mm 1 Row	Inlet / Outlet	28 / 28
Oil Cooler	350mm		
Condenser	CNX011	Receiver Drier	RDX612

Notes: Multi-Fit. Oil cooler fittings included.

FOR40067

To suit Mazda 323 Astina BA - BJ
4 cyl 1.6 & 1.8L 8/1994 - 3/2004



ALUMINIUM / PLASTIC
MANUAL

Core Height	330mm	Core Width	690mm
Core Thickness	24mm 1 Row	Inlet / Outlet	28 / 28
Oil Cooler	N/A		
Condenser	CNX011	Receiver Drier	RDX612

Notes: Multi-Fit

FOR40120

To suit Mazda 323 Astina BA - BJ
4 cyl 1.6 & 1.8L 8/1994 - 3/2004



COPPER / BRASS
AUTOMATIC

Core Height	325mm	Core Width	692mm
Core Thickness	32mm 2 Row	Inlet / Outlet	29 / 29
Oil Cooler	350mm		
Condenser	CNX011	Receiver Drier	RDX612

Notes:

MAZ40142

To suit Mazda 323 Astina BA
4 cyl 1.6, 1.8 & 2.0L 9/1998 - 6/2002



ALUMINIUM / PLASTIC
AUTOMATIC

Core Height	330mm	Core Width	688mm
Core Thickness	16mm 1 Row	Inlet / Outlet	28 / 28
Oil Cooler	350mm		
Condenser	CNX759	Receiver Drier	RDX182

Notes:

MAZ08031

To suit Mazda 323 Astina BA
4 cyl 1.6, 1.8L & V6 2.0L 8/1994 - 3/2004



ALUMINIUM / PLASTIC
AUTOMATIC

Core Height	670mm	Core Width	344mm
Core Thickness	27mm 1 Row	Inlet / Outlet	35 / 35
Oil Cooler	N/A		
Condenser	CNX007	Receiver Drier	RDX182

Notes:

MAZ40140

To suit Mazda 323 Astina BA
4 cyl 1.6, 1.8L V6 2.0L 8/1994 - 9/1998



Core Height	670mm	Core Width	368mm
Core Thickness	24mm 1 Row	Inlet / Outlet	32 / 32
Oil Cooler	225mm		
Condenser		Receiver Drier	RDX477

Notes: Oil Cooler 1 X barb, 1 F/F fittings

MAZ81471

To suit Mazda 323 Astina BA
4 cyl 1.8 & 2.0L 8/1994 - 9/1998



Core Height	675mm	Core Width	340mm
Core Thickness	27mm 1 Row	Inlet / Outlet	35 / 35
Oil Cooler	N/A		
Condenser	CNX102	Receiver Drier	RDX087

Notes:

MAZ1801

To suit Mazda 323 Astina BA
4 cyl 1.8L & V6 2.0L 8/1994 - 9/1998



Core Height	674mm	Core Width	340mm
Core Thickness	26mm 1 Row	Inlet / Outlet	31 / 31
Oil Cooler	N/A		
Condenser	CNX007	Receiver Drier	RDX182

Notes:

M33CM

To suit Mazda 323 Astina BA
4 cyl 1.8L 8/1994 - 3/2004



Core Height	325mm	Core Width	680mm
Core Thickness	16mm 1 Row	Inlet / Outlet	29 / 29
Oil Cooler	N/A		
Condenser	CNX011	Receiver Drier	RDX612

Notes:

MAZ40050

To suit Mazda 323 Astina BG
4 cyl 1.6 & 1.8L 10/1989 - 11/1996



Core Height	390mm	Core Width	640mm
Core Thickness	32mm 2 Row	Inlet / Outlet	33 / 33
Oil Cooler	275mm		
Condenser	CNX007	Receiver Drier	RDX180

Notes:

MAZ40052

To suit Mazda 323 Astina BG
4 cyl 1.6 & 1.8L 10/1989 - 11/1996



Core Height	350mm	Core Width	646mm
Core Thickness	16mm 1 Row	Inlet / Outlet	33 / 33
Oil Cooler	N/A		
Condenser	CNX007	Receiver Drier	RDX182

Notes:

FOR40059

To suit Mazda 323 Astina BG
4 cyl 1.8L 10/1989 - 11/1996



Core Height	390mm	Core Width	648mm
Core Thickness	24mm 1 Row	Inlet / Outlet	31 / 31
Oil Cooler	270mm		
Condenser	CNX007	Receiver Drier	RDX180

Notes:

MAZ1774

To suit Mazda 323 Astina BG
4 cyl 1.8L 10/1989 - 8/1994



Core Height	350mm	Core Width	645mm
Core Thickness	16mm 1 Row	Inlet / Outlet	32 / 32
Oil Cooler	275mm		
Condenser	CNX007	Receiver Drier	RDX182

Notes:

FOR40057

To suit Mazda 323 BG
4 cyl 1.8L 10/1989 - 12/1997



Core Height	390mm	Core Width	648mm
Core Thickness	24mm 1 Row	Inlet / Outlet	32 / 32
Oil Cooler	N/A		
Condenser	CNX007	Receiver Drier	RDX180

Notes:

FOR40055

To suit Mazda 323 BG
4 cyl 1.6L 10/1989 - 12/1997



Core Height	390mm	Core Width	570mm
Core Thickness	16mm 1 Row	Inlet / Outlet	32 / 32
Oil Cooler	N/A		
Condenser	CNX007	Receiver Drier	RDX180

Notes:

FOR40051

To suit Mazda 323 BG
4 cyl 1.6 & 1.8L 10/1989 - 11/1996



Core Height	348mm	Core Width	570mm
Core Thickness	24mm 1 Row	Inlet / Outlet	35 / 35
Oil Cooler	N/A		
Condenser	CNX006	Receiver Drier	RDX086

Notes:

FOR40053

To suit Mazda 323 BG
4 cyl 1.6 & 1.8L 10/1989 - 11/1996



Core Height	348mm	Core Width	570mm
Core Thickness	24mm 1 Row	Inlet / Outlet	35 / 35
Oil Cooler	200mm		
Condenser	CNX006	Receiver Drier	RDX086

Notes:

M14CA

To suit Mazda 323 BF, BW SI & II
4 cyl 1.6L 1/1985 - 10/1989



COPPER / PLASTIC
AUTOMATIC



Core Height	350mm	Core Width	448mm
Core Thickness	32mm 2 Row	Inlet / Outlet	36 / 36
Oil Cooler	225mm		
Condenser	CNX006	Receiver Drier	RDX086

Notes:

M13CM

To suit Mazda 323 BF, Bus SI & II
4 cyl 1.6L 1/1985 - 10/1989



COPPER / PLASTIC
MANUAL



Core Height	350mm	Core Width	528mm
Core Thickness	16mm 1 Row	Inlet / Outlet	36 / 36
Oil Cooler	N/A		
Condenser	CNX006	Receiver Drier	RDX086

Notes:

MAZ40051

To suit Mazda 323 BD Series & I BD Series 1
4 cyl 1.3L 11/1982 - 10/1985



COPPER / BRASS
MANUAL



Core Height	300mm	Core Width	590mm
Core Thickness	32mm 2 Row	Inlet / Outlet	36 / 36
Oil Cooler	N/A		
Condenser		Receiver Drier	RDX086

Notes:

MAZ40151

To suit Mazda 323 FA
4 cyl 1.3 & 1.4L 1/1977 - 11/1982



COPPER / BRASS
MANUAL



Core Height	300mm	Core Width	420mm
Core Thickness	32mm 2 Row	Inlet / Outlet	36 / 36
Oil Cooler	N/A		
Condenser		Receiver Drier	RDX086

Notes:

G28CA

To suit Mazda 6 GH
4 cyl 2.5L 2/2008 >



ALUMINIUM / PLASTIC
AUTOMATIC



Core Height	375mm	Core Width	730mm
Core Thickness	16mm 1 Row	Inlet / Outlet	32 / 32
Oil Cooler	350mm		
Condenser		Receiver Drier	

Notes: H Clip lower fan mount

MAZ1249

To suit Mazda 6 GH
4 cyl 2.5L 2/2008 >



ALUMINIUM / PLASTIC
AUTOMATIC



Core Height	375mm	Core Width	725mm
Core Thickness	16mm 1 Row	Inlet / Outlet	32 / 32
Oil Cooler	350mm		
Condenser		Receiver Drier	

Notes: H Clip lower fan mount

MAZ1830

To suit Mazda 6 GG GY
4 cyl 2.3L 8/2002 - 2/2006



Core Height	380mm	Core Width	730mm
Core Thickness	25mm 1 Row	Inlet / Outlet	32 / 32
Oil Cooler	350mm		
Condenser	CNX116	Receiver Drier	RDX0050

Notes: No Filler Neck, Dowel lower fan mount

MAZ1858

To suit Mazda 6 GG GY
4 cyl 2.3L 8/2002 - 2/2006



Core Height	375mm	Core Width	680mm
Core Thickness	16mm 1 Row	Inlet / Outlet	32 / 32
Oil Cooler	350mm		
Condenser	CNX116	Receiver Drier	RDX0050

Notes: H Clip lower fan mount

MAZ69671

To suit Mazda 6 GG GY
4 cyl 2.3L 8/2002 / 2/2008



Core Height	375mm	Core Width	753mm
Core Thickness	16mm 1 Row	Inlet / Outlet	30 / 30
Oil Cooler	N/A		
Condenser	CNX116	Receiver Drier	

Notes: 8mm Bleeder Pipe, Dowel fan mount

MAZ54251

To suit Mazda 6 GG GY
4 cyl 2.3 8/2002 - 2/2008



Core Height	375mm	Core Width	752mm
Core Thickness	23mm 1 Row	Inlet / Outlet	32 / 32
Oil Cooler	N/A		
Condenser	CNX116	Receiver Drier	RDX0050

Notes: Dowel lower fan mount

G30CM

To suit Mazda 6 GG
4 cyl 2.3L 8/2005 - 2/2008



Core Height	375mm	Core Width	725mm
Core Thickness	16mm 1 Row	Inlet / Outlet	32 / 32
Oil Cooler	350mm		
Condenser	CNX116	Receiver Drier	RDX0050

Notes: Dowel lower fan mount

MAZ1829

To suit Mazda 6 GG GY
4 cyl 2.3L 8/2002 - 2/2006

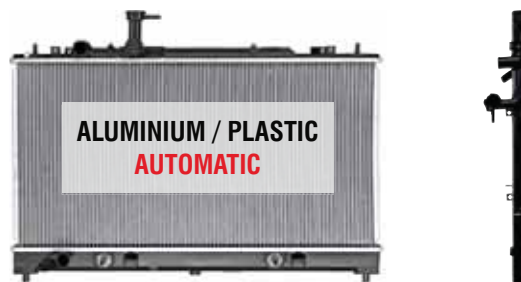

Core Height	380mm	Core Width	730mm
Core Thickness	16mm 1 Row	Inlet / Outlet	32 / 32
Oil Cooler	350mm		
Condenser	CNX116	Receiver Drier	RDX0050

Notes: 8mm Bleed Pipe, Dowel fan mount

MAZ40130

To suit Mazda 626 GE
V6 2.5L 12/1991 - 8/1997



Core Height	688mm	Core Width	338mm
Core Thickness	32mm 2 Rows	Inlet / Outlet	36 / 36
Oil Cooler	225mm		
Condenser	CNX103	Receiver Drier	RDX182

Notes:

MAZ40135

To suit Mazda 626 GE MX-6
V6 2.5L 12/1991 - 8/1997



Core Height	690mm	Core Width	348mm
Core Thickness	24mm 1 Row	Inlet / Outlet	36 / 36
Oil Cooler	225mm		
Condenser	CNX102	Receiver Drier	RDX087

Notes:

MAZ40120

To suit Mazda 626 GE GF
4 cyl 2.0L 1/1991 - 8/2002



Core Height	688mm	Core Width	338mm
Core Thickness	32mm 2 Rows	Inlet / Outlet	36 / 36
Oil Cooler	300mm		
Condenser	CNX102	Receiver Drier	RDX087

Notes:

MAZ40125

To suit Mazda 626 GE GF
4 cyl 2.0L 1/1991 - 8/2002



Core Height	688mm	Core Width	338mm
Core Thickness	32mm 2 Row	Inlet / Outlet	36 / 36
Oil Cooler	225mm		
Condenser	CNX102	Receiver Drier	RDX087

Notes:

MAZ81471

To suit Mazda 626 GE GF
4 cyl 2.0L & V6 2.5L 12/1991 - 8/2002



Core Height	675mm	Core Width	340mm
Core Thickness	27mm 1 Row	Inlet / Outlet	35 / 35
Oil Cooler	N/A		
Condenser	CNX102	Receiver Drier	RDX087

Notes:

MAZ40103

To suit Mazda 626 GD MX-6
4 cyl 2.2L inc Turbo 10/1987 - 5/1995



Core Height	400mm	Core Width	640mm
Core Thickness	32mm 2 Row	Inlet / Outlet	36 / 36
Oil Cooler	300mm		
Condenser	CNX014	Receiver Drier	RDX089

Notes:

MAZ40100

To suit Mazda 626 CB
4 cyl 2.0L 12/1978 - 2/1983



COPPER / BRASS
MANUAL

Core Height	350mm	Core Width	490mm
Core Thickness	32mm 2 Row	Inlet / Outlet	36 / 36
Oil Cooler	N/A		
Condenser		Receiver Drier	

Notes:

MAZ40201

To suit Mazda 929 HC HD
V6 3.0L 7/1991 - 8/1998

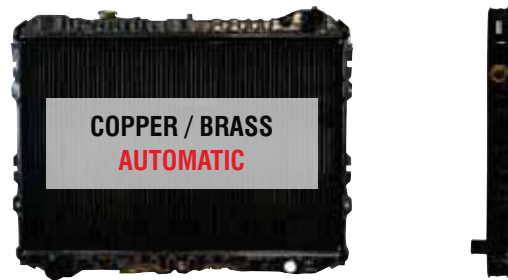

COPPER / BRASS
AUTOMATIC

Core Height	430mm	Core Width	645mm
Core Thickness	32mm 2 Row	Inlet / Outlet	36 / 43
Oil Cooler	350mm		
Condenser		Receiver Drier	RDX089

Notes: 2 Senders

MAZ40220

To suit Mazda 929 HC HD
V6 3.0L 7/1991 - 8/1998



ALUMINIUM / PLASTIC
AUTOMATIC

Core Height	430mm	Core Width	648mm
Core Thickness	24mm 1 Row	Inlet / Outlet	36 / 42
Oil Cooler	350mm		
Condenser	CNX113	Receiver Drier	RDX281

Notes:

MAZ40200

To suit Mazda 929 HB
4 cyl 1.8L 1/1974 - 6/1978



COPPER / BRASS
MANUAL

Core Height	330mm	Core Width	460mm
Core Thickness	32mm 2 Row	Inlet / Outlet	36 / 36
Oil Cooler	N/A		
Condenser		Receiver Drier	

Notes:

MAZ40420

To suit Mazda B1600
4 cyl 1.6L 7/1971 - 10/1977



COPPER / BRASS
MANUAL

Core Height	325mm	Core Width	450mm
Core Thickness	32mm 2 Row	Inlet / Outlet	36 / 37
Oil Cooler	N/A		
Condenser		Receiver Drier	

Notes:

FOR40315

To suit Mazda Bounty
4 cyl 2.5L Turbo Diesel 1/1999 - 12/2005 (NZ)



ALUMINIUM / PLASTIC
AUTOMATIC

Core Height	454mm	Core Width	648mm
Core Thickness	24mm 1 Row	Inlet / Outlet	35 / 35
Oil Cooler	375mm		
Condenser	CNX008	Receiver Drier	RDX022

Notes: Suits Thailand OE

FOR40318

To suit Mazda Bounty

4 cyl 2.5L Turbo Diesel 1/1999 - 12/2005 (NZ)



ALUMINIUM / PLASTIC
AUTOMATIC

Core Height	454mm	Core Width	648mm
Core Thickness	32mm 1 Row	Inlet / Outlet	35 / 35
Oil Cooler	375mm		
Condenser	CNX008	Receiver Drier	RDX022

Notes: Multi-Fit

FOR40315

To suit Mazda Bravo B2500 B2600

4 cyl 2.6L & 2.5L Turbo Diesel 11/1991 - 1/2007



ALUMINIUM / PLASTIC
AUTOMATIC

Core Height	454mm	Core Width	648mm
Core Thickness	24mm 1 Row	Inlet / Outlet	35 / 35
Oil Cooler	375mm		
Condenser	CNX008	Receiver Drier	RDX022

Notes: Suits Thailand OE

FOR40316

To suit Mazda Bravo B2500 B2600

4 cyl 2.6L & 2.5L Turbo Diesel 11/1991 - 1/2007



ALUMINIUM / PLASTIC
MANUAL

Core Height	454mm	Core Width	648mm
Core Thickness	24mm 1 Row	Inlet / Outlet	35 / 35
Oil Cooler	N/A		
Condenser	CNX008	Receiver Drier	RDX022

Notes: Suits Thailand OE

FOR40318

To suit Mazda Bravo B2500 B2600

4 cyl 2.6L & 2.5L Turbo Diesel 11/1991 - 1/2007



ALUMINIUM / PLASTIC
AUTOMATIC

Core Height	454mm	Core Width	648mm
Core Thickness	32mm 1 Row	Inlet / Outlet	35 / 35
Oil Cooler	375mm		
Condenser	CNX008	Receiver Drier	RDX022

Notes: Multi-Fit

FOR40319

To suit Mazda Bravo B2500 B2600

4 cyl 2.6L & 2.5L Turbo Diesel 11/1991 - 1/2007



ALUMINIUM / PLASTIC
MANUAL

Core Height	454mm	Core Width	648mm
Core Thickness	32mm 1 Row	Inlet / Outlet	35 / 35
Oil Cooler	N/A		
Condenser	CNX008	Receiver Drier	RDX022

Notes: Multi-Fit

15-FOR40319

To suit Mazda Bravo B2500 B2600

4 cyl 2.6L & 2.5L Turbo Diesel 11/1991 - 1/2007



ALUMINIUM / PLASTIC
MANUAL

Core Height	454mm	Core Width	648mm
Core Thickness	32mm 1 Row	Inlet / Outlet	35 / 35
Oil Cooler	N/A		
Condenser	CNXD008	Receiver Drier	RDX022

Notes: Multi-Fit

M32CM

To suit Mazda Bravo B2600
4 cyl 2.6L & 2.5L Turbo Diesel
12/1994 - 7/2006



ALUMINIUM / PLASTIC
MANUAL

Core Height	450mm	Core Width	640mm
Core Thickness	27mm 1 Row	Inlet / Outlet	36 / 36
Oil Cooler	N/A		
Condenser	CNX008	Receiver Drier	RDX086

Notes:

FOR43022

To suit Mazda Bravo B2600
4 cyl 2.6L 1/1992 - 1/1996



ALUMINIUM / PLASTIC
MANUAL

Core Height	400mm	Core Width	645mm
Core Thickness	32mm 1 Row	Inlet / Outlet	35 / 35
Oil Cooler	N/A		
Condenser	CNX2860	Receiver Drier	RDX026

Notes:

FOR43020

To suit Mazda Bravo B2600
4 cyl 2.6L 1/1990 - 7/2006



ALUMINIUM / PLASTIC
AUTOMATIC

Core Height	400mm	Core Width	645mm
Core Thickness	32mm 1 Row	Inlet / Outlet	35 / 35
Oil Cooler	350mm		
Condenser	CNX008	Receiver Drier	RDX022

Notes:

MAZ40400

To suit Mazda Bravo B2200 B2600
4 cyl 2.6L & 2.2L Diesel 3/1987 - 3/1996



COPPER / BRASS
AUTOMATIC

Core Height	400mm	Core Width	640mm
Core Thickness	32mm 2 Row	Inlet / Outlet	36 / 36
Oil Cooler	350mm		
Condenser	CNX2860	Receiver Drier	RDX026

Notes:

MAZ40350

To suit Mazda Bravo B2600
4 cyl 2.0, 2.6L Petrol & 2.5L Diesel
3/1987 - 11/2002



COPPER / BRASS
MANUAL

Core Height	400mm	Core Width	640mm
Core Thickness	29mm 2 Row	Inlet / Outlet	36 / 36
Oil Cooler	N/A		
Condenser	CNX2860	Receiver Drier	RDX026

Notes:

MAZ40430

To suit Mazda Bravo B2600
4 cyl 2.6L 3/1987 - 12/1991



COPPER / BRASS
AUTOMATIC

Core Height	375mm	Core Width	588mm
Core Thickness	32mm 2 Row	Inlet / Outlet	36 / 36
Oil Cooler	275mm		
Condenser	CNX008	Receiver Drier	RDX022

Notes:

MAZ40401

To suit Mazda Bravo B2000 B2200
4 cyl 2.0L Petrol & 2.2L Diesel 6/1985 - 12/1991

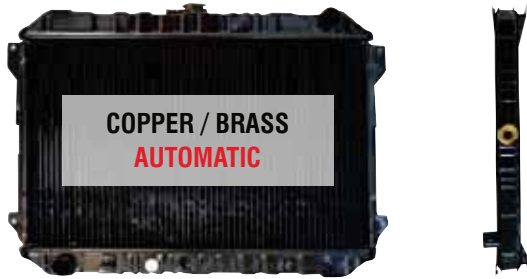

Core Height	375mm	Core Width	590mm
Core Thickness	32mm 2 Row	Inlet / Outlet	36 / 36
Oil Cooler	250mm		
Condenser	CNX2860	Receiver Drier	RDX086

Notes:

FOR40319

To suit Mazda BT50 B2500 B3000
4 cyl 2.5 & 3.0L Turbo Diesel 11/2006 >



Core Height	454mm	Core Width	648mm
Core Thickness	32mm 1 Row	Inlet / Outlet	35 / 35
Oil Cooler	N/A		
Condenser	CNX400 / CNX409	Receiver Drier	RDX0050 / RDX191

Notes: Multi-Fit

15-FOR40319

To suit Mazda BT50 B2500 B3000
4 cyl 2.5 & 3.0L Turbo Diesel 11/2006 >



Core Height	454mm	Core Width	648mm
Core Thickness	32mm 1 Row	Inlet / Outlet	35 / 35
Oil Cooler	N/A		
Condenser	CNX400 / CNX409	Receiver Drier	RDX0050 / RDX191

Notes: Multi-Fit

MAZ40125

To suit Mazda Capella
4 cyl 2.0L 1/1997 - 12/2002 (NZ)



Core Height	688mm	Core Width	338mm
Core Thickness	32mm 2 Row	Inlet / Outlet	36 / 36
Oil Cooler	225mm		
Condenser	CNX102	Receiver Drier	RDX087

Notes:

MAZ1719

To suit Mazda CX-7 ER MZR
4 cyl 2.3 & 2.5L inc Turbo 11/2006 >

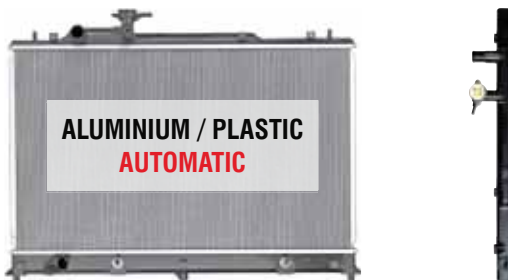

Core Height	450mm	Core Width	750mm
Core Thickness	26mm 1 Row	Inlet / Outlet	32 / 32
Oil Cooler	375mm		
Condenser	CNX1480	Receiver Drier	

Notes:

G24CA

To suit Mazda CX-7 ER MZR
4 cyl 2.3 & 2.5L Turbo 11/2006 >



Core Height	450mm	Core Width	750mm
Core Thickness	26mm 1 Row	Inlet / Outlet	32 / 32
Oil Cooler	380mm		
Condenser	CNX1480	Receiver Drier	

Notes:

G25CA

To suit Mazda CX-9 TB
V6 3.7L 12/2007 >



ALUMINIUM / PLASTIC
AUTOMATIC

Core Height	500mm	Core Width	745mm
Core Thickness	27mm 1 Row	Inlet / Outlet	35 / 35
Oil Cooler	380mm		
Condenser	CNX3521	Receiver Drier	RDX0070

Notes:

MAZ1088

To suit Mazda CX-9 TB
V6 3.7L 12/2007 >



ALUMINIUM / PLASTIC
AUTOMATIC

Core Height	500mm	Core Width	750mm
Core Thickness	27mm 1 Row	Inlet / Outlet	35 / 35
Oil Cooler	380mm		
Condenser	CNX3521	Receiver Drier	RDX0070

Notes: 10 & 15mm Connector T/Tank. 19 & 20mm Connector B/Tank

G8CA

To suit Mazda Demio
4 cyl 1.3 & 1.5L 1/1996 - 12/2002 (NZ)



ALUMINIUM / PLASTIC
AUTOMATIC

Core Height	349mm	Core Width	380mm
Core Thickness	27mm 1 Row	Inlet / Outlet	28 / 28
Oil Cooler	275mm		
Condenser	CNX010	Receiver Drier	RDX283

Notes:

M43CM

To suit Mazda E1800 E2000
4 cyl 1.8 & 2.0L 10/1999 - 5/2007



ALUMINIUM / PLASTIC
MANUAL

Core Height	350mm	Core Width	545mm
Core Thickness	16mm 1 Row	Inlet / Outlet	37 / 37
Oil Cooler	N/A		
Condenser	CNX410	Receiver Drier	RDX5810

Notes:

M40CM

To suit Mazda E1800 E2000
4 cyl 1.8 & 2.0L 1/1995 - 12/2002



ALUMINIUM / PLASTIC
MANUAL

Core Height	350mm	Core Width	545mm
Core Thickness	16mm 1 Row	Inlet / Outlet	35 / 35
Oil Cooler	N/A		
Condenser		Receiver Drier	RDX025

Notes: 1 sender port. No plug.

FOR40210

To suit Mazda E1800
4 cyl 1.8L 2/1984 - 12/1996



COPPER / BRASS
MANUAL

Core Height	350mm	Core Width	556mm
Core Thickness	45mm 3 Row	Inlet / Outlet	35 / 35
Oil Cooler	N/A		
Condenser	CNX401	Receiver Drier	RDX025

Notes:

G23CM

To suit Mazda E2000
4 cyl 2.0L 11/2001 - 5/2007



ALUMINIUM / PLASTIC
MANUAL

Core Height	424mm	Core Width	545mm
Core Thickness	27mm 1 Row	Inlet / Outlet	35 / 35
Oil Cooler	N/A		
Condenser	CNX410	Receiver Drier	RDX5510

Notes:

FOR40200

To suit Mazda E2200
4 cyl 2.2L Diesel 5/1981 - 8/1997



COPPER / BRASS
MANUAL

Core Height	350mm	Core Width	570mm
Core Thickness	49mm 3 Row	Inlet / Outlet	36 / 36
Oil Cooler	N/A		
Condenser		Receiver Drier	

Notes:

G21CM

To suit Mazda E2500 WL
4 cyl 2.5L Diesel 8/1997 - 5/2003



ALUMINIUM / PLASTIC
MANUAL

Core Height	450mm	Core Width	640mm
Core Thickness	27mm 1 Row	Inlet / Outlet	35 / 35
Oil Cooler	N/A		
Condenser		Receiver Drier	

Notes:

FOR40065

To suit Mazda Familia
4 cyl 2.0L 1/1999 - 12/2003 (NZ)



ALUMINIUM / PLASTIC
AUTOMATIC

Core Height	330mm	Core Width	690mm
Core Thickness	24mm 1 Row	Inlet / Outlet	28 / 28
Oil Cooler	350mm		
Condenser	CNX011	Receiver Drier	RDX612

Notes: Multi-Fit. Oil cooler fitting included.

MAZ40142

To suit Mazda Familia
4 cyl 1.5 & 2.0L 1/1999 - 12/2003 (NZ)



ALUMINIUM / PLASTIC
AUTOMATIC

Core Height	330mm	Core Width	688mm
Core Thickness	16mm 1 Row	Inlet / Outlet	28 / 28
Oil Cooler	350mm		
Condenser	CNX759	Receiver Drier	RDX182

Notes:

FOR40120

To suit Mazda Familia
4 cyl 1.5, 1.6 & 1.8L 1/1994 - 12/1999 (NZ)



COPPER / BRASS
AUTOMATIC

Core Height	325mm	Core Width	692mm
Core Thickness	32mm 2 Row	Inlet / Outlet	29 / 29
Oil Cooler	350mm		
Condenser	CNX011	Receiver Drier	RDX612

Notes:

FOR40059

To suit Mazda Familia
4 cyl 1.3 & 1.5L 1/1989 - 12/1996 (NZ)



ALUMINIUM / PLASTIC
AUTOMATIC

Core Height	390mm	Core Width	648mm
Core Thickness	24mm 1 Row	Inlet / Outlet	31 / 31
Oil Cooler	270mm		
Condenser	CNX007	Receiver Drier	RDX180

Notes:

FOR40057

To suit Mazda Familia
4 cyl 1.3 & 1.5L 1/1989 - 12/1996 (NZ)



ALUMINIUM / PLASTIC
MANUAL

Core Height	390mm	Core Width	648mm
Core Thickness	24mm 1 Row	Inlet / Outlet	32 / 32
Oil Cooler	N/A		
Condenser	CNX007	Receiver Drier	RDX180

Notes:

MAZ40050

To suit Mazda Familia
4 cyl 1.3 & 1.5L 1/1989 - 12/1996 (NZ)

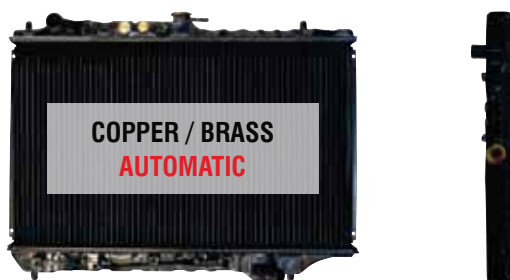

COPPER / BRASS
AUTOMATIC

Core Height	390mm	Core Width	640mm
Core Thickness	32mm 2 Row	Inlet / Outlet	33 / 33
Oil Cooler	275mm		
Condenser	CNX007	Receiver Drier	RDX180

Notes: 1 sender port. No plug.

FOR40120

To suit Mazda Lantis
4 cyl 1.8L 1/1993 - 12/1997 (NZ)



COPPER / BRASS
AUTOMATIC

Core Height	325mm	Core Width	692mm
Core Thickness	32mm 2 Row	Inlet / Outlet	29 / 29
Oil Cooler	350mm		
Condenser	CNX011	Receiver Drier	RDX612

Notes:

G19CA

To suit Mazda MPV LW
V6 3.0L 1/2002 - 11/2006



ALUMINIUM / PLASTIC
AUTOMATIC

Core Height	430mm	Core Width	640mm
Core Thickness	28mm 1 Row	Inlet / Outlet	34 / 42
Oil Cooler	350mm		
Condenser	CNX4410	Receiver Drier	RDX0040

Notes:

MAZ40220

To suit Mazda MPV GY
V6 2.5 & 3.0L 9/1993 - 6/2002



ALUMINIUM / PLASTIC
AUTOMATIC

Core Height	430mm	Core Width	648mm
Core Thickness	24mm 1 Row	Inlet / Outlet	36 / 42
Oil Cooler	350mm		
Condenser	CNX113	Receiver Drier	RDX281

Notes:

MAZ40157

To suit Mazda MX-5 NB
4 cyl 1.8L 3/1998 - 9/2005



Core Height	318mm	Core Width	648mm
Core Thickness	16mm 1 Row	Inlet / Outlet	32 / 32
Oil Cooler	275mm		
Condenser		Receiver Drier	

Notes:

MAZ40158

To suit Mazda MX-5 NB
4 cyl 1.8L 3/1998 - 9/2005



Core Height	318mm	Core Width	648mm
Core Thickness	16mm 1 Row	Inlet / Outlet	32 / 32
Oil Cooler	N/A		
Condenser		Receiver Drier	

Notes:

MAZ40155

To suit Mazda MX-5 NA NB
4 cyl 1.8L 11/1993 - 9/2005



Core Height	320mm	Core Width	650mm
Core Thickness	24mm 1 Row	Inlet / Outlet	32 / 32
Oil Cooler	275mm		
Condenser	CNX2070	Receiver Drier	RDX087

Notes:

MAZ40156

To suit Mazda MX-5 NA NB
4 cyl 1.6 & 1.8L 11/1993 - 11/2000



Core Height	320mm	Core Width	650mm
Core Thickness	24mm 1 Row	Inlet / Outlet	32 / 32
Oil Cooler	N/A		
Condenser	CNX2070	Receiver Drier	RDX087

Notes:

FOR43020

To suit Mazda Proceed
4 cyl 2.6L 1/1991 - 12/1996 (NZ)



Core Height	400mm	Core Width	645mm
Core Thickness	32mm 1 Row	Inlet / Outlet	35 / 35
Oil Cooler	350mm		
Condenser	CNX008	Receiver Drier	RDX022

Notes:

MAZ40300

To suit Mazda RX-7 FC SI & II
Rotary 1.3L inc Turbo 1/1986 - 2/1992



Core Height	430mm	Core Width	558mm
Core Thickness	32mm 2 Row	Inlet / Outlet	39 / 39
Oil Cooler	350mm		
Condenser		Receiver Drier	RDX086

Notes:

MAZ40180

To suit Mazda RX-8 FE
Rotary 1.3L 7/2003 >



Core Height	360mm	Core Width	645mm
Core Thickness	32mm 1 Row	Inlet / Outlet	35 / 35
Oil Cooler	70mm		
Condenser		Receiver Drier	RDX608

Notes:

MAZ1867

To suit Mazda Tribute
4 cyl 2.3L 1/2004 - 12/2007



Core Height	700mm	Core Width	452mm
Core Thickness	26mm 1 Row	Inlet / Outlet	35 / 35
Oil Cooler	305mm		
Condenser	CNX115	Receiver Drier	RDX183

Notes:

MAZ2436

To suit Mazda Tribute YF
4 cyl 2.0L 2/2001 - 1/2004



Core Height	700mm	Core Width	452mm
Core Thickness	28mm 1 Row	Inlet / Outlet	28 / 28
Oil Cooler	N/A		
Condenser	CNX115	Receiver Drier	RDX183

Notes:

MAZ1866

To suit Mazda Tribute
V6 3.0L 1/2000 - 12/2008



Core Height	700mm	Core Width	445mm
Core Thickness	25mm 1 Row	Inlet / Outlet	32 / 32
Oil Cooler	305mm		
Condenser	CNX115	Receiver Drier	RDX183

Notes:

MER21491

To suit Mercedes-Benz Actros
6 cyl 12.0 & 16.0L 1/2003 - 1/2006



Core Height	1015mm	Core Width	800mm
Core Thickness	40mm 1 Row	Inlet / Outlet	65 / 65
Oil Cooler	500mm		
Condenser		Receiver Drier	RDX678

Notes:

MER21211

To suit Mercedes-Benz Actros
6 cyl 12.0 & 16.0L Turbo Diesel 6/1998 - 1/2003



Core Height	817mm	Core Width	808mm
Core Thickness	42mm 4 row	Inlet / Outlet	65 / 65
Oil Cooler	N/A		
Condenser		Receiver Drier	RDX678

Notes:

MER21231

To suit Mercedes-Benz Actros
6 cyl 12.0 & 16.0L Turbo Diesel
6/1998 - 1/2003



Core Height	950mm	Core Width	805mm
Core Thickness	40mm 1 Row	Inlet / Outlet	65 / 65
Oil Cooler	500mm		
Condenser		Receiver Drier	RDX678

Notes:

MER58021

To suit Mercedes-Benz Atego
6 cyl 4.2, 4.8, 6.4L Turbo Diesel
1/2001 - 12/2008



Core Height	575mm	Core Width	510mm
Core Thickness	42mm	Inlet / Outlet	50 / 40 / 50
Oil Cooler	N/A		
Condenser		Receiver Drier	

Notes:

MER58031

To suit Mercedes-Benz Atego
6 cyl 4.2, 4.8, 6.4L Turbo Diesel
1/2001 - 12/2009



Core Height	570mm	Core Width	288mm
Core Thickness	42mm	Inlet / Outlet	40 / 50 / 28
Oil Cooler	N/A		
Condenser		Receiver Drier	

Notes:

MER22351

To suit Mercedes-Benz Bus 580 Series
6 cyl Turbo Diesel 1999 >



Core Height	1065mm	Core Width	680mm
Core Thickness	54mm 1 Row	Inlet / Outlet	58 / 58
Oil Cooler	N/A		
Condenser		Receiver Drier	

Notes:

MER21111

To suit Mercedes-Benz Bus & Truck W670 614D
4 cyl 4.0L 1996 >



Core Height	570mm	Core Width	560mm
Core Thickness	42mm 1 Row	Inlet / Outlet	42 / 42
Oil Cooler	300mm		
Condenser		Receiver Drier	

Notes:

MER09751

To suit Mercedes-Benz LK SERIES 1517
Diesel 170hp



Core Height	544mm	Core Width	630mm
Core Thickness	46mm 2 Row	Inlet / Outlet	42 / 42
Oil Cooler	N/A		
Condenser		Receiver Drier	

Notes:

MER21171

To suit Mercedes-Benz MK/SK
3238, 3544, 3538 V10
13.0 & 15.0L 1987 - 1996



Core Height	850mm	Core Width	638mm
Core Thickness	42mm 1 Row	Inlet / Outlet	58 / 58
Oil Cooler	350mm		
Condenser		Receiver Drier	

Notes:

MER21141

To suit Mercedes-Benz NG/SK 2435
1987 - 1994

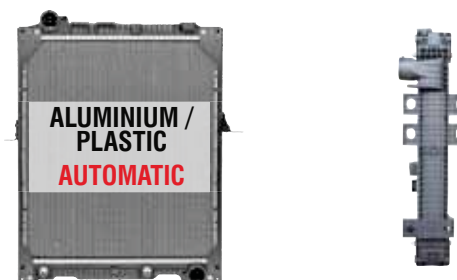

Core Height	730mm	Core Width	638mm
Core Thickness	42mm	Inlet / Outlet	65 / 65
Oil Cooler	350mm		
Condenser		Receiver Drier	

Notes:

MER21151

To suit Mercedes-Benz SK Truck
6 cyl 9.6, 10.9, 12.7 & 14.6L 1/1992 - 1/1998



Core Height	810mm	Core Width	638mm
Core Thickness	42mm	Inlet / Outlet	
Oil Cooler	350mm		
Condenser		Receiver Drier	

Notes:

MER11091

To suit Mercedes-Benz R129 280 - 320SL
6 cyl 2.8L 11/1995 - 12/1998



Core Height	670mm	Core Width	480mm
Core Thickness	32mm 2 Row	Inlet / Outlet	36 / 36
Oil Cooler	275mm		
Condenser		Receiver Drier	

Notes:

MER11181

To suit Mercedes-Benz R129 500SL
V8 5.0L 5/1990 - 9/1993



Core Height	665mm	Core Width	465mm
Core Thickness	42mm 1 Row	Inlet / Outlet	38 / 38
Oil Cooler	350mm		
Condenser		Receiver Drier	

Notes:

MER21101

To suit Mercedes-Benz R170 SLK200
4 cyl 2.0L 1996 - 2000



Core Height	360mm	Core Width	434mm
Core Thickness	33mm	Inlet / Outlet	35 / 35
Oil Cooler	275mm		
Condenser		Receiver Drier	

Notes: 21mm Bypass Fitting

MER12421

To suit Mercedes-Benz W124 230 - 320E,
E280 - 320
4 & 6 cyl 2/1986 - 1/1997



Core Height	535mm	Core Width	480mm
Core Thickness	43mm 1 Row	Inlet / Outlet	36 / 36
Oil Cooler	375mm		
Condenser	CNX584	Receiver Drier	RDX203

Notes:

MER12441

To suit Mercedes-Benz W124 230E, 230GE
4 cyl 2.3L 2/1986 - 9/1993



Core Height	490mm	Core Width	480mm
Core Thickness	42mm 1 Row	Inlet / Outlet	35 / 35
Oil Cooler	375mm		
Condenser	CNX584	Receiver Drier	RDX203

Notes:

MER11331

To suit Mercedes-Benz W124 230E, 230GE
4 cyl 2.3L 2/1986 - 9/1993



Core Height	410mm	Core Width	365mm
Core Thickness	42mm 1 Row	Inlet / Outlet	35 / 35
Oil Cooler	275mm		
Condenser	CNX584	Receiver Drier	RDX203

Notes:

MER12461

To suit Mercedes-Benz W124 300D, E300
5 & 6 cyl 2/1986 - 9/1994



Core Height	535mm	Core Width	485mm
Core Thickness	42mm 1 Row	Inlet / Outlet	35 / 35
Oil Cooler	375mm		
Condenser	CNX584	Receiver Drier	RDX203

Notes:

MER11101

To suit Mercedes-Benz W124 300D, E300
5 & 6 cyl 3.0L 2/1986 - 9/1994



Core Height	615mm	Core Width	480mm
Core Thickness	42mm 1 Row	Inlet / Outlet	35 / 35
Oil Cooler	375mm		
Condenser	CNX584	Receiver Drier	RDX203

Notes:

MER11311

To suit Mercedes-Benz W124, W201
4 cyl 1.8, 2.0 & 2.3L 12/1984 - 2/1994



Core Height	290mm	Core Width	345mm
Core Thickness	42mm 1 Row	Inlet / Outlet	30 / 30
Oil Cooler	275mm		
Condenser		Receiver Drier	RDX206

Notes:

MER10501

To suit Mercedes-Benz W126 280SE
6 cyl 2.7L 2/1981 - 4/1986



Core Height	415mm	Core Width	570mm
Core Thickness	35mm 2 Row	Inlet / Outlet	35 / 35
Oil Cooler	328mm		
Condenser	CNX789	Receiver Drier	RDX204

Notes:

MER13291

To suit Mercedes-Benz W126 300SE, SEL
6 cyl 3.0L 4/1986 - 9/1993



Core Height	485mm	Core Width	480mm
Core Thickness	44mm 1 Row	Inlet / Outlet	36 / 36
Oil Cooler	375mm		
Condenser	CNX792	Receiver Drier	RDX217

Notes:

MER12524

To suit Mercedes-Benz W126 380 - 560SE
3.8, 4.2, 5.0 & 5.5L 1979 - 1991



Core Height	428mm	Core Width	668mm
Core Thickness	42mm	Inlet / Outlet	38 / 38/ 20
Oil Cooler	N/A		
Condenser		Receiver Drier	

Notes:

MER10531

To suit Mercedes-Benz W123 230E, 240D,
280E, 300D
2.4, 2.7, 2.8 & 3.0L 11/1976 - 2/1986



Core Height	415mm	Core Width	490mm
Core Thickness	34mm 1 Row	Inlet / Outlet	35 / 35
Oil Cooler	325mm		
Condenser	CNX583	Receiver Drier	RDX202

Notes:

MER12591

To suit Mercedes-Benz W140, W220
S280 - S430
6 cyl, V6 & V8 9/1993 - 2/2007



Core Height	641mm	Core Width	480mm
Core Thickness	26mm 1 Row	Inlet / Outlet	32 / 32
Oil Cooler	275mm		
Condenser		Receiver Drier	

Notes:

MER12201

To suit Mercedes-Benz W140 300SE, C200,
S280, 320
4 & 6 cyl 3/1992 - 11/2000



Core Height	665mm	Core Width	470mm
Core Thickness	32mm 2 Row	Inlet / Outlet	39 / 39
Oil Cooler	315mm		
Condenser	CNX594	Receiver Drier	RDX213

Notes:

MER11521

To suit Mercedes-Benz W140 300SE S320
6 cyl 3.2L 3/1992 - 4/1999



ALUMINIUM / PLASTIC
AUTOMATIC

Core Height	670mm	Core Width	470mm
Core Thickness	34mm 2 Row	Inlet / Outlet	38 / 38
Oil Cooler	360mm		
Condenser	CNX594	Receiver Drier	RDX213

Notes:

MER11171

To suit Mercedes-Benz W140 400 - 500SE
V8 4.2 & 5.0L 3/1992 - 9/1999



ALUMINIUM / PLASTIC
AUTOMATIC

Core Height	670mm	Core Width	465mm
Core Thickness	42mm 1 Row	Inlet / Outlet	42 / 42
Oil Cooler	310mm		
Condenser	CNX594	Receiver Drier	RDX213

Notes:

MER18571

To suit Mercedes-Benz W163 ML270 - 500
5 cyl V6 & V8 9/1998 - 12/2005



ALUMINIUM / PLASTIC
AUTOMATIC & MANUAL

Core Height	610mm	Core Width	540mm
Core Thickness	32mm 1 Row	Inlet / Outlet	36 / 36
Oil Cooler	200 / 250mm		
Condenser	CNX581	Receiver Drier	

Notes: Twin Oil cooler

MER13051

To suit Mercedes-Benz W168 A140
4 cyl 1.4, 1.6 & 1.9L 10/1998 - 4/2005



ALUMINIUM / PLASTIC
AUTOMATIC & MANUAL

Core Height	600mm	Core Width	350mm
Core Thickness	24mm 1 Row	Inlet / Outlet	33 / 33
Oil Cooler	275mm		
Condenser	CNX591	Receiver Drier	RDX218

Notes:

MER13041

To suit Mercedes-Benz W168 A140
4 cyl 1.4, 1.6 & 1.9L 10/1998 - 4/2005



ALUMINIUM / PLASTIC
AUTOMATIC

Core Height	600mm	Core Width	380mm
Core Thickness	24mm 1 Row	Inlet / Outlet	32 / 32
Oil Cooler	275mm		
Condenser	CNX591	Receiver Drier	RDX218

Notes:

MER30561

To suit Mercedes-Benz W169/W245
A150, A170, A180, A200, B180, B200
4/2005 >



ALUMINIUM / PLASTIC
AUTOMATIC

Core Height	650mm	Core Width	410mm
Core Thickness	26mm 1 Row	Inlet / Outlet	35 / 35
Oil Cooler	315mm		
Condenser	CNX598	Receiver Drier	RDX246

Notes:

MER21021

To suit Mercedes-Benz W169, W245, A150, A170, A180, B180
4/2005 >



Core Height	600mm	Core Width	375mm
Core Thickness	26mm	Inlet / Outlet	35 / 35
Oil Cooler	N/A		
Condenser	CNX812	Receiver Drier	RDX676 / RDX677

Notes:

MER21031

To suit Mercedes-Benz W169, W245, A150, A170, A180, B180
4/2005 >



Core Height	650mm	Core Width	405mm
Core Thickness	26mm 1 Row	Inlet / Outlet	35 / 35
Oil Cooler	310mm		
Condenser	CNX812	Receiver Drier	RDX676 / RDX677

Notes:

MER11371

To suit Mercedes-Benz W201 190E
4 cyl 2.3L 9/1990 - 10/1992



Core Height	485mm	Core Width	450mm
Core Thickness	38mm 2 Row	Inlet / Outlet	36 / 36
Oil Cooler	325mm		
Condenser		Receiver Drier	RDX206

Notes:

MER12531

To suit Mercedes-Benz W201 190E W201
6 cyl 2.6L 7/1987 - 2/1992



Core Height	550mm	Core Width	440mm
Core Thickness	34mm 1 Row	Inlet / Outlet	30 / 30
Oil Cooler	325mm		
Condenser	CNX596	Receiver Drier	RDX206

Notes:

MER12311

To suit Mercedes-Benz W201 190D
5 cyl 2.5L Diesel 1/1986 - 12/1989



Core Height	575mm	Core Width	448mm
Core Thickness	42mm 1 Row	Inlet / Outlet	32 / 32
Oil Cooler	325mm		
Condenser	CNX596	Receiver Drier	RDX206

Notes:

MER12291

To suit Mercedes-Benz W201 180 - 190E
4 cyl 1.8 & 2.0L 12/1984 - 2/1994



Core Height	575mm	Core Width	450mm
Core Thickness	34mm 2 Row	Inlet / Outlet	32 / 32
Oil Cooler	325mm		
Condenser	CNX589	Receiver Drier	RDX206

Notes:

MER14011

To suit Mercedes-Benz W201 190D 190E
6 cyl 2.6L 1983 - 1993



ALUMINIUM / PLASTIC
AUTOMATIC

Core Height	580mm	Core Width	370mm
Core Thickness	32mm 1 Row	Inlet / Outlet	35 / 35
Oil Cooler	280mm		
Condenser		Receiver Drier	

Notes:

MER11251

To suit Mercedes-Benz W202 C200
4 cyl 2.0 & 2.3L 11/1996 - 11/2000



ALUMINIUM / PLASTIC
AUTOMATIC & MANUAL

Core Height	520mm	Core Width	418mm
Core Thickness	34mm	Inlet / Outlet	32 / 32
Oil Cooler	N/A		
Condenser	CNX622	Receiver Drier	RDX045

Notes:

MER11191

To suit Mercedes-Benz W202 C180 - C280
4, 5 & 6 cyl inc Turbo 2/1994 - 11/2000



ALUMINIUM / PLASTIC
AUTOMATIC

Core Height	615mm	Core Width	420mm
Core Thickness	42mm 1 Row	Inlet / Outlet	36 / 36
Oil Cooler	275mm		
Condenser	CNX580	Receiver Drier	RDX217

Notes:

MER11231

To suit Mercedes-Benz W202 C280
6 cyl 2.8 & 3.6L 2/1994 - 12/2000



ALUMINIUM / PLASTIC
AUTOMATIC

Core Height	615mm	Core Width	420mm
Core Thickness	42mm 1 Row	Inlet / Outlet	36 / 36
Oil Cooler	275mm		
Condenser	CNX786	Receiver Drier	RDX217

Notes:

MER12021

To suit Mercedes-Benz W202, W210,
C180 - C280
4 cyl & V6 2/1994 - 7/2002



ALUMINIUM / PLASTIC
AUTOMATIC

Core Height	615mm	Core Width	420mm
Core Thickness	30mm 2 Row	Inlet / Outlet	36 / 36
Oil Cooler	275mm		
Condenser	CNX580	Receiver Drier	RDX217

Notes:

MER14331

To suit Mercedes-Benz W203 C180 - C320
4 cyl & V6 inc Supercharged 11/2000 - 4/2008



ALUMINIUM / PLASTIC
AUTOMATIC

Core Height	650mm	Core Width	405mm
Core Thickness	24mm 1 Row	Inlet / Outlet	48 / 48
Oil Cooler	315mm		
Condenser	CNX792	Receiver Drier	RDX217

Notes:

MER49551

To suit Mercedes-Benz W204 C200 - C350
2007 >



ALUMINIUM / PLASTIC
AUTOMATIC

Core Height	620mm	Core Width	484mm
Core Thickness	32mm	Inlet / Outlet	47 / 47
Oil Cooler	N/A		
Condenser		Receiver Drier	

Notes:

MER12741

To suit Mercedes-Benz W210 E200
4 cyl 2.0L Supercharged 8/2000 - 9/2005



ALUMINIUM / PLASTIC
AUTOMATIC

Core Height	641mm	Core Width	496mm
Core Thickness	33mm	Inlet / Outlet	38 / 38
Oil Cooler	315mm		
Condenser	CNX595	Receiver Drier	RDX930

Notes:

MER12401

To suit Mercedes-Benz W210 S210, E55
V8 5.4L inc Supercharged 4/1998 - 9/2006



ALUMINIUM / PLASTIC
AUTOMATIC

Core Height	640mm	Core Width	490mm
Core Thickness	40mm 1 Row	Inlet / Outlet	32 / 32
Oil Cooler	N/A		
Condenser	CNX595	Receiver Drier	RDX930

Notes:

MER11151

To suit Mercedes-Benz W210 E300
Turbo Diesel, E430
6 cyl & V8 7/1997 - 8/2002



ALUMINIUM / PLASTIC
AUTOMATIC

Core Height	640mm	Core Width	490mm
Core Thickness	42mm 1 Row	Inlet / Outlet	38 / 38
Oil Cooler	N/A		
Condenser	CNX595	Receiver Drier	RDX930

Notes: Oil cooler on grill side

MER10231

To suit Mercedes-Benz W210 E200
4 cyl & V6 inc Supercharged 1/1996 - 9/2005



ALUMINIUM / PLASTIC
AUTOMATIC

Core Height	640mm	Core Width	490mm
Core Thickness	32mm 2 Row	Inlet / Outlet	38 / 38
Oil Cooler	315mm		
Condenser	CNX595	Receiver Drier	RDX930

Notes:

MER20381

To suit Mercedes-Benz W210 E280, E320
6 cyl & V6 1/1996 - 8/2002



ALUMINIUM / PLASTIC
AUTOMATIC

Core Height	640mm	Core Width	492mm
Core Thickness	34mm 2 Row	Inlet / Outlet	39 / 39
Oil Cooler	310mm		
Condenser	CNX595	Receiver Drier	RDX930

Notes:

MER11191

To suit Mercedes-Benz W210 S210, E230
4 cyl 2.3L 1/1996 - 1/1998



ALUMINIUM / PLASTIC
AUTOMATIC

Core Height	615mm	Core Width	420mm
Core Thickness	42mm 1 Row	Inlet / Outlet	36 / 36
Oil Cooler	275mm		
Condenser	CNX580	Receiver Drier	RDX217

Notes:

MER18011

To suit Mercedes-Benz W211, S211,
E240 - 350
V6 2.6, 3.0 & 3.5L 8/2002 - 12/2009



ALUMINIUM / PLASTIC
AUTOMATIC & MANUAL

Core Height	640mm	Core Width	440mm
Core Thickness	22mm 1 Row	Inlet / Outlet	42 / 27 / 42
Oil Cooler	210mm		
Condenser	CNX794	Receiver Drier	RDX932

Notes:

MER69781

To suit Mercedes-Benz W211, S211
E63, E200 - 500
4 & 5 cyl V6 & V8 inc Supercharged 8/2002 - 12/2009



ALUMINIUM / PLASTIC
AUTOMATIC

Core Height	640mm	Core Width	470mm
Core Thickness	34mm	Inlet / Outlet	50 / 50
Oil Cooler	N/A		
Condenser		Receiver Drier	

Notes: Oil Cooler fittings on grill side

MER16331

To suit Mercedes-Benz W220 CL55, C215,
S55, S320 - 600
V8 & V12 4/1999 - 2/2007



ALUMINIUM / PLASTIC
AUTOMATIC & MANUAL

Core Height	645mm	Core Width	475mm
Core Thickness	42mm 1 Row	Inlet / Outlet	42 / 42
Oil Cooler	275mm		
Condenser		Receiver Drier	

Notes:

MER12571

To suit Mercedes-Benz W220 C CLASS CLK
V8 & V12 4/1998 - 2/2007



ALUMINIUM / PLASTIC
AUTOMATIC

Core Height	640mm	Core Width	475mm
Core Thickness	42mm 1 Row	Inlet / Outlet	42 / 42
Oil Cooler	275mm		
Condenser		Receiver Drier	RDX215

Notes:

MER56131

To suit Mercedes-Benz W639
Viano Vito 109, 111, 115, 120
4 cyl & V6 5/2005 - 1/2006



ALUMINIUM / PLASTIC
AUTOMATIC & MANUAL

Core Height	650mm	Core Width	396mm
Core Thickness	32mm	Inlet / Outlet	38 / 38 / 30
Oil Cooler	N/A		
Condenser		Receiver Drier	

Notes:

MER19741

To suit Mercedes-Benz W639 Viano,
Vito 639
4 cyl & V6 inc Turbo 5/2005 >



Core Height	680mm	Core Width	405mm
Core Thickness	26mm 1 Row	Inlet / Outlet	38 / 30 / 38
Oil Cooler	N/A		
Condenser	CNX799	Receiver Drier	RDX207

Notes:

MER14311

To suit Mercedes-Benz W638 Vito 109,
112, 115CDI
4 cyl Diesel inc Turbo 1/2001 - 1/2009



Core Height	570mm	Core Width	560mm
Core Thickness	42mm 1 Row	Inlet / Outlet	42 / 42
Oil Cooler	300mm		
Condenser	CNX787	Receiver Drier	RDX671

Notes:

MER21411

To suit Mercedes-Benz W638
Vito 108, 112, 113, 115, 119
4 cyl 2.1, 2.2, 2.3L 1/1998 - 1/2007



Core Height	570mm	Core Width	560mm
Core Thickness	40mm 1 Row	Inlet / Outlet	42 / 42
Oil Cooler	300mm		
Condenser	CNX787	Receiver Drier	RDX671

Notes:

MER21391

To suit Mercedes-Benz W639 Vito 108D
4 cyl 2.3L Diesel 1/1998 - 7/1999



Core Height	560mm	Core Width	570mm
Core Thickness	42mm 2 Row	Inlet / Outlet	42 / 42
Oil Cooler	300mm		
Condenser	CNX787	Receiver Drier	RDX671

Notes:

MER14321

To suit Mercedes-Benz W638 Vito
4 cyl 2.2L Turbo Diesel 1998 - 2004



Core Height	570mm	Core Width	555mm
Core Thickness	27mm 2 Row	Inlet / Outlet	42 / 42
Oil Cooler	N/A		
Condenser	CNX787	Receiver Drier	RDX671

Notes:

MER22001

To suit Mercedes-Benz W901
Sprinter 208, 308, 313, 413 CDI
4 cyl 2.1L Turbo Diesel 1/2000 - 10/2006



Core Height	675mm	Core Width	405mm
Core Thickness	42mm 1 Row	Inlet / Outlet	42 / 30 / 42
Oil Cooler	N/A		
Condenser		Receiver Drier	

Notes:

MER21631

To suit Mercedes-Benz W901
 Sprinter 208, 308, 313, 413 CDI
 4 cyl 2.1L Turbo Diesel 1/2000 - 10/2006



ALUMINIUM / PLASTIC
MANUAL

Core Height	680mm	Core Width	405mm
Core Thickness	42mm 1 Row	Inlet / Outlet	42 / 29 / 42
Oil Cooler	N/A		
Condenser		Receiver Drier	

Notes:

MER21201

To suit Mercedes-Benz W901
 Sprinter 208CDI, 308, 312, 412
 4 & 5 cyl inc Turbo 1/1998 - 12/2006



ALUMINIUM / PLASTIC
MANUAL

Core Height	680mm	Core Width	400mm
Core Thickness	33mm 2 Row	Inlet / Outlet	42 / 42
Oil Cooler	N/A		
Condenser		Receiver Drier	

Notes:

MER21431

To suit Mercedes-Benz W901
 Sprinter 312, 412D
 5 cyl 2.9L Turbo Diesel 1/1998 - 4/2001



ALUMINIUM / PLASTIC
MANUAL

Core Height	680mm	Core Width	405mm
Core Thickness	42mm 1 Row	Inlet / Outlet	42 / 42
Oil Cooler	N/A		
Condenser		Receiver Drier	

Notes:

MER21441

To suit Mercedes-Benz W901
 Sprinter 308, 312
 5 cyl 2.9L Turbo Diesel 1998 >



ALUMINIUM / PLASTIC
AUTOMATIC

Core Height	680mm	Core Width	400mm
Core Thickness	42mm 1 Row	Inlet / Outlet	42 / 42
Oil Cooler	275mm		
Condenser		Receiver Drier	

Notes:

MIN49511

To suit Mini Cooper R50 R53 R56
 4 cyl 1.6L 1/2002 - 3/2009



ALUMINIUM / PLASTIC
AUTOMATIC & MANUAL

Core Height	575mm	Core Width	395mm
Core Thickness	26mm 1 Row	Inlet / Outlet	32 / 32
Oil Cooler	N/A		
Condenser	CNX900	Receiver Drier	RDX6711

Notes:

MIN49501

To suit Mini Cooper R50, R53
 4 cyl 1.6L 3/2002 - 3/2009



ALUMINIUM / PLASTIC
MANUAL

Core Height	575mm	Core Width	395mm
Core Thickness	26mm 1 Row	Inlet / Outlet	32 / 32
Oil Cooler	N/A		
Condenser	CNX900	Receiver Drier	RDX6711

Notes:

MIN49521

To suit Mini Cooper R50 R52 R53
4 cyl 1.6L inc Supercharged 1/2002 - 3/2009



ALUMINIUM / PLASTIC
MANUAL

Core Height	575mm	Core Width	395mm
Core Thickness	26mm 1 Row	Inlet / Outlet	32 / 32
Oil Cooler	N/A		
Condenser	CNX900	Receiver Drier	RDX6711

Notes:

MIN54221

To suit Mini Cooper R50 R56
4 cyl 1.6L Petrol & Turbo Diesel 3/2002 >



ALL ALUMINIUM
MANUAL

Core Height	580mm	Core Width	335mm
Core Thickness	24mm 1 Row	Inlet / Outlet	32 / 32
Oil Cooler	N/A		
Condenser	CNX900	Receiver Drier	RDX6711

Notes:

MIN54591

To suit Mini Cabriolet R55, R56, R57
4 cyl 1.6L inc Turbo 3/2007 >



ALUMINIUM / PLASTIC
AUTOMATIC & MANUAL

Core Height	600mm	Core Width	420mm
Core Thickness	18mm 1 Row	Inlet / Outlet	32 / 32
Oil Cooler	N/A		
Condenser		Receiver Drier	

Notes:

MIT42038

To suit Mitsubishi 380 DB
V6 3.8L 9/2005 - 12/2008



ALUMINIUM / PLASTIC
AUTOMATIC

Core Height	400mm	Core Width	755mm
Core Thickness	16mm 1 Row	Inlet / Outlet	35 / 35
Oil Cooler	375mm		
Condenser	CNX0190	Receiver Drier	RDX0040

Notes:

MIT42039

To suit Mitsubishi 380 DB
V6 3.8L 9/2005 - 12/2008



ALUMINIUM / PLASTIC
MANUAL

Core Height	400mm	Core Width	755mm
Core Thickness	16mm 1 Row	Inlet / Outlet	35 / 35
Oil Cooler	N/A		
Condenser	CNX0190	Receiver Drier	RDX0040

Notes:

MIT2085

To suit Mitsubishi Canter 3.5T
6 cyl 3.5L Diesel 1995 - 1996



ALUMINIUM / PLASTIC
MANUAL

Core Height	555mm	Core Width	465mm
Core Thickness	46mm 3 Row	Inlet / Outlet	48 / 48
Oil Cooler	N/A		
Condenser		Receiver Drier	

Notes:

MIT1363

To suit Mitsubishi Canter 5.5L & 6.8L
4 cyl Turbo Diesel 1996 >



Core Height	550mm	Core Width	530mm
Core Thickness	40mm 1 Row	Inlet / Outlet	46 / 46
Oil Cooler	N/A		
Condenser		Receiver Drier	

Notes:

MIT45021

To suit Mitsubishi Challenger PA
V6 3.0L 3/1998 - 4/2007



Core Height	500mm	Core Width	642mm
Core Thickness	32mm 2 Row	Inlet / Outlet	37 / 37
Oil Cooler			
Condenser	CNX088	Receiver Drier	RDX608

Notes: 8.5mm Tube Pitch

MIT45020

To suit Mitsubishi Challenger PA
V6 3.0L 3/1998 - 4/2007



Core Height	500mm	Core Width	642mm
Core Thickness	32mm 2 Row	Inlet / Outlet	37 / 37
Oil Cooler	350mm		
Condenser	CNX088	Receiver Drier	RDX608

Notes: 8.5mm Tube Pitch

J42CA

To suit Mitsubishi Challenger PA
V6 3.0L 3/1998 - 4/2007



Core Height	423mm	Core Width	638mm
Core Thickness	28mm 1 Row	Inlet / Outlet	36 / 36
Oil Cooler	350mm		
Condenser	CNX088	Receiver Drier	RDX608

Notes:

MIT41013

To suit Mitsubishi Chariot
4 cyl 2.4L 1/1991 - 12/2002 (NZ)



Core Height	376mm	Core Width	660mm
Core Thickness	32mm 2 Row	Inlet / Outlet	36 / 36
Oil Cooler	350mm		
Condenser	CNX085	Receiver Drier	RDX603

Notes: 1 x Sender port

MIT1496

To suit Mitsubishi Colt RG
4 cyl 1.5L 8/2004 >



Core Height	625mm	Core Width	380mm
Core Thickness	16mm 1 Row	Inlet / Outlet	29 / 29
Oil Cooler	200mm		
Condenser		Receiver Drier	

Notes:

J15CA

To suit Mitsubishi Diamante
V6 2.5 & 3.0L 1/1995 - 12/2001 (NZ)



ALUMINIUM / PLASTIC
AUTOMATIC

Core Height	400mm	Core Width	718mm
Core Thickness	27mm 2 Row	Inlet / Outlet	36 / 36
Oil Cooler	375mm		
Condenser	CNX080	Receiver Drier	RDX603

Notes:

MIT42030

To suit Mitsubishi Diamante
V6 2.5 & 3.0L 1/1995 - 12/2001 (NZ)



ALUMINIUM / PLASTIC
AUTOMATIC

Core Height	400mm	Core Width	718mm
Core Thickness	24mm 1 Row	Inlet / Outlet	35 / 35
Oil Cooler	375mm		
Condenser	CNX080	Receiver Drier	RDX603

Notes:

15-MIT42030

To suit Mitsubishi Diamante
V6 2.5 & 3.0L 1/1995 - 12/2001 (NZ)



ALUMINIUM / PLASTIC
AUTOMATIC

Core Height	400mm	Core Width	718mm
Core Thickness	24mm 1 Row	Inlet / Outlet	35 / 35
Oil Cooler	375mm		
Condenser	CNX080	Receiver Drier	RDX603

Notes:

MIT42020

To suit Mitsubishi Diamante
V6 2.5 & 3.0L 1/1990 - 12/1995 (NZ)

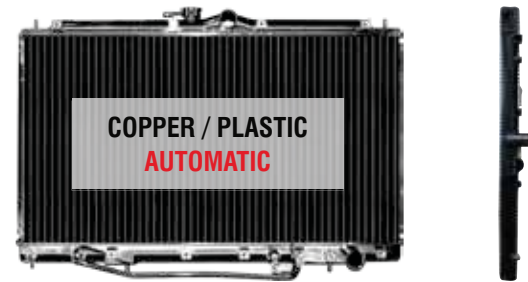

COPPER / PLASTIC
AUTOMATIC

Core Height	398mm	Core Width	727mm
Core Thickness	38mm 2 Row	Inlet / Outlet	35 / 35
Oil Cooler	375mm		
Condenser	CNX076	Receiver Drier	RDX282

Notes:

MIT1211

To suit Mitsubishi Fuso FK, FM Series
6 cyl 7.5L Diesel



ALUMINIUM / PLASTIC
MANUAL

Core Height	630mm	Core Width	600mm
Core Thickness	36mm 1 Row	Inlet / Outlet	46 / 46
Oil Cooler	N/A		
Condenser		Receiver Drier	

Notes:

MIT1214

To suit Mitsubishi Fuso Super GRT, FV, KL
2003 >



ALUMINIUM / PLASTIC
MANUAL

Core Height	810mm	Core Width	730mm
Core Thickness	53mm	Inlet / Outlet	67, 38, 67
Oil Cooler	N/A		
Condenser		Receiver Drier	

Notes:

MIT1125

To suit Mitsubishi Fuso FV Series
6 cyl Turbo Diesel 1996 - 2000



Core Height	850mm	Core Width	730mm
Core Thickness	53mm 2 Row	Inlet / Outlet	67 / 38 / 67
Oil Cooler	N/A		
Condenser		Receiver Drier	

Notes:

MIT41013

To suit Mitsubishi Galant HJ
V6 2.0L 4/1993 - 12/1995 (NZ)



Core Height	376mm	Core Width	660mm
Core Thickness	32mm 2 Row	Inlet / Outlet	36 / 36
Oil Cooler	350mm		
Condenser	CNX085	Receiver Drier	RDX603

Notes:

MIT1144

To suit Mitsubishi Grandis BA
4 cyl 2.4L 5/2004 >



Core Height	425mm	Core Width	740mm
Core Thickness	16mm 1 Row	Inlet / Outlet	35 / 35
Oil Cooler	N/A		
Condenser	CNX8490	Receiver Drier	RDX0070

Notes:

MIT44540

To suit Mitsubishi L300 Express SJ, WA
4 cyl 2.0 & 2.4L Petrol 10/1994 - 5/2004



Core Height	505mm	Core Width	585mm
Core Thickness	24mm 1 Row	Inlet / Outlet	36 / 36
Oil Cooler	300mm		
Condenser	CNX309	Receiver Drier	RDX030 / RDX608

Notes: 8.5mm Tube Pitch

MIT44542

To suit Mitsubishi L300 Express SJ, WA
4 cyl 2.0 & 2.4L Petrol 1/1994 - 3/2006



Core Height	505mm	Core Width	585mm
Core Thickness	24mm 1 Row	Inlet / Outlet	36 / 36
Oil Cooler	N/A		
Condenser	CNX309	Receiver Drier	RDX030 / RDX608

Notes: 8.5mm Tube Pitch

MIT44545

To suit Mitsubishi L300 Express SH, SJ
4 cyl 2.5L Diesel 1/1992 - 5/2004



Core Height	500mm	Core Width	585mm
Core Thickness	16mm 1 Row	Inlet / Outlet	36 / 36
Oil Cooler	300mm		
Condenser	CNX309	Receiver Drier	RDX608 / RDX030

Notes: 8.5mm Tube Pitch

MIT44520

To suit Mitsubishi L300 Express SF - SJ
4 cyl 2.5L Diesel 10/1986 - 9/1995



COPPER / BRASS
MANUAL



Core Height	395mm	Core Width	490mm
Core Thickness	45mm 3 Row	Inlet / Outlet	36 / 36
Oil Cooler	N/A		
Condenser	CNX309	Receiver Drier	RDX030 / RDX608

Notes:

MIT44501

To suit Mitsubishi L300 Express SF - SJ
4 cyl 2.0 & 2.4L 10/1986 - 10/2000



COPPER / BRASS
MANUAL



Core Height	400mm	Core Width	590mm
Core Thickness	45mm 3 Row	Inlet / Outlet	36 / 36
Oil Cooler	N/A		
Condenser		Receiver Drier	RDX022

Notes:

MIT44527

To suit Mitsubishi L300 Express SF - SH
4 cyl 2.0 & 2.4L 10/1986 - 9/1994



ALUMINIUM / PLASTIC
MANUAL



Core Height	392mm	Core Width	587mm
Core Thickness	32mm 1 Row	Inlet / Outlet	35 / 35
Oil Cooler	N/A		
Condenser	CNX309	Receiver Drier	RDX030 / RDX608

Notes:

MIT44525

To suit Mitsubishi L300 Express SE - SH
4 cyl 2.0 & 2.4L 7/1985 - 9/1995



COPPER / BRASS
MANUAL



Core Height	400mm	Core Width	587mm
Core Thickness	45mm 3 Row	Inlet / Outlet	34 / 34
Oil Cooler	N/A		
Condenser		Receiver Drier	

Notes:

MIT44500

To suit Mitsubishi L300 Express SA - SE
4 cyl 1.6, 1.8 & 2.0L 4/1982 - 10/1986



COPPER / BRASS
MANUAL



Core Height	348mm	Core Width	490mm
Core Thickness	32mm 2 Row	Inlet / Outlet	36 / 37
Oil Cooler	N/A		
Condenser		Receiver Drier	RDX022

Notes:

MIT2233

To suit Mitsubishi Lancer CH
4 cyl 2.4L 8/2005 - 10/2009



ALUMINIUM / PLASTIC
AUTOMATIC



Core Height	375mm	Core Width	690mm
Core Thickness	27mm 1 Row	Inlet / Outlet	35 / 35
Oil Cooler	300mm		
Condenser	CNX098	Receiver Drier	RDX624

Notes: Sensor Port in Bottom Tank

MIT41060

To suit Mitsubishi Lancer CG, CH
4 cyl 2.0 & 2.4L 7/2002 - 10/2009



ALUMINIUM / PLASTIC
MANUAL

Core Height	380mm	Core Width	685mm
Core Thickness	16mm 1 Row	Inlet / Outlet	35 / 35
Oil Cooler	N/A		
Condenser	CNX097	Receiver Drier	RDX624

Notes:

MIT41050

To suit Mitsubishi Lancer CG, CH
4 cyl 2.0 & 2.4L 7/2002 - 10/2009



ALUMINIUM/ PLASTIC
AUTOMATIC

Core Height	380mm	Core Width	685mm
Core Thickness	16mm 1 Row	Inlet / Outlet	35 / 35
Oil Cooler	300mm		
Condenser	CNX097	Receiver Drier	RDX624

Notes:

MIT1029

To suit Mitsubishi Lancer EVO 7 8 9
4 cyl 2.0L Turbo 5/2001 - 7/2008



ALUMINIUM / PLASTIC
MANUAL

Core Height	375mm	Core Width	680mm
Core Thickness	36mm 1 Row	Inlet / Outlet	36 / 36
Oil Cooler	N/A		
Condenser	CNX097	Receiver Drier	RDX624

Notes:

MIT41040

To suit Mitsubishi Lancer CE
4 cyl 1.5 & 1.8L 7/1996 - 11/2004



ALUMINIUM / PLASTIC
MANUAL

Core Height	375mm	Core Width	655mm
Core Thickness	16mm 1 Row	Inlet / Outlet	35 / 35
Oil Cooler	N/A		
Condenser	CNX083	Receiver Drier	RDX608

Notes:

J27CA

To suit Mitsubishi Lancer CE
4 cyl 1.5 & 1.8L 7/1996 - 11/2004



ALUMINIUM / PLASTIC
AUTOMATIC

Core Height	375mm	Core Width	660mm
Core Thickness	16mm 1 Row	Inlet / Outlet	35 / 35
Oil Cooler	300mm		
Condenser	CNX089	Receiver Drier	RDX608

Notes:

MIT41030

To suit Mitsubishi Lancer CE
4 cyl 1.5 & 1.8L 7/1996 - 11/2004



ALUMINIUM / PLASTIC
AUTOMATIC

Core Height	375mm	Core Width	658mm
Core Thickness	16mm 1 Row	Inlet / Outlet	35 / 35
Oil Cooler	300mm		
Condenser	CNX089	Receiver Drier	RDX608

Notes:

MIT41014

To suit Mitsubishi Lancer CB - CC
4 cyl 1.5, 1.6 & 1.8L 9/1990 - 7/1996



Core Height	376mm	Core Width	660mm
Core Thickness	32mm 2 Row	Inlet / Outlet	36 / 36
Oil Cooler	N/A		
Condenser	CNX085	Receiver Drier	RDX603

Notes:

J22CM

To suit Mitsubishi Lancer CB - CC
4 cyl 1.5, 1.6 & 1.8L 9/1990 - 7/1996



Core Height	375mm	Core Width	661mm
Core Thickness	27mm 1 Row	Inlet / Outlet	36 / 36
Oil Cooler	N/A		
Condenser	CNX085	Receiver Drier	RDX603

Notes: Sensor Port in Bottom Tank

MIT41013

To suit Mitsubishi Lancer CB - CC
4 cyl 1.5, 1.6 & 1.8L 9/1990 - 7/1996



Core Height	376mm	Core Width	660mm
Core Thickness	32mm 2 Row	Inlet / Outlet	36 / 36
Oil Cooler	350mm		
Condenser	CNX085	Receiver Drier	RDX603

Notes: 1 x Sender Port

J16CA

To suit Mitsubishi Lancer CB - CC
4 cyl 1.5, 1.6 & 1.8L 9/1990 - 7/1996



Core Height	375mm	Core Width	660mm
Core Thickness	27mm 1 Row	Inlet / Outlet	35 / 35
Oil Cooler	300mm		
Condenser	CNX085	Receiver Drier	RDX603

Notes:

MIT211

To suit Mitsubishi Lancer CA
4 cyl 1.5L 9/1988 - 8/1990



Core Height	378mm	Core Width	668mm
Core Thickness	32mm 2 Row	Inlet / Outlet	36 / 36
Oil Cooler	350mm		
Condenser	CNX085	Receiver Drier	RDX603

Notes:

MIT1208

To suit Mitsubishi Lancer CA - CB
4 cyl 1.5L 9/1988 - 1990



Core Height	378mm	Core Width	668mm
Core Thickness	16mm 1 Row	Inlet / Outlet	28 / 36
Oil Cooler	325mm		
Condenser	CNX085	Receiver Drier	RDX603

Notes: Sensor Port in Bottom Tank

MIT41013

To suit Mitsubishi Libero
4 cyl 1.8L 1/1992 - 12/2000 (NZ)



COPPER / PLASTIC
AUTOMATIC

Core Height	376mm	Core Width	660mm
Core Thickness	32mm 2 Row	Inlet / Outlet	36 / 36
Oil Cooler	350mm		
Condenser	CNX085	Receiver Drier	RDX603

Notes: 1 x Sender port

MIT42030

To suit Mitsubishi Magna TE - TW
4 cyl 2.4L, V6 3.0 & 3.5L 4/1996 - 5/2006



ALUMINIUM / PLASTIC
AUTOMATIC

Core Height	400mm	Core Width	718mm
Core Thickness	24mm 1 Row	Inlet / Outlet	35 / 35
Oil Cooler	375mm		
Condenser	CNX080	Receiver Drier	RDX603

Notes:

15-MIT42030

To suit Mitsubishi Magna TE - TW
4 cyl 2.4L, V6 3.0 & 3.5L 4/1996 - 5/2006



ALUMINIUM / PLASTIC
AUTOMATIC

Core Height	400mm	Core Width	718mm
Core Thickness	24mm 1 Row	Inlet / Outlet	35 / 35
Oil Cooler	375mm		
Condenser	CNX080	Receiver Drier	RDX603

Notes:

J15CA

To suit Mitsubishi Magna TE - TW
4 cyl 2.4L, V6 3.0 & 3.5L 4/1996 - 5/2006



ALUMINIUM / PLASTIC
AUTOMATIC

Core Height	400mm	Core Width	718mm
Core Thickness	27mm 2 Row	Inlet / Outlet	36 / 36
Oil Cooler	375mm		
Condenser	CNX080	Receiver Drier	RDX603

Notes:

MIT42020

To suit Mitsubishi Magna TR - TS
4 cyl 2.6L & V6 3.0L 11/1991 - 3/1998

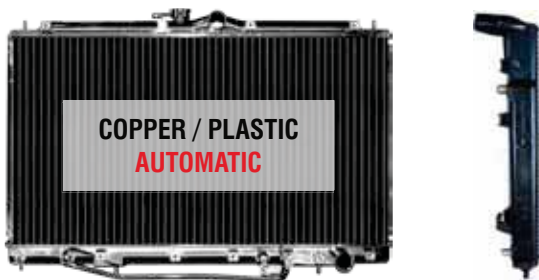

COPPER / PLASTIC
AUTOMATIC

Core Height	398mm	Core Width	727mm
Core Thickness	38mm 2 Row	Inlet / Outlet	35 / 35
Oil Cooler	375mm		
Condenser	CNX076	Receiver Drier	RDX282

Notes:

MIT42010

To suit Mitsubishi Magna TM - TP
4 cyl 2.6L 4/1985 - 12/1991



COPPER / BRASS
AUTOMATIC

Core Height	375mm	Core Width	648mm
Core Thickness	32mm 2 Row	Inlet / Outlet	35 / 35
Oil Cooler	300mm		
Condenser	CNX078	Receiver Drier	RDX086

Notes:

MIT41030

To suit Mitsubishi Mirage CE
4 cyl 1.5L 7/1996 - 8/2004



Core Height	375mm	Core Width	658mm
Core Thickness	16mm 1 Row	Inlet / Outlet	35 / 35
Oil Cooler	300mm		
Condenser	CNX089	Receiver Drier	RDX608

Notes:

MIT41040

To suit Mitsubishi Mirage CE
4 cyl 1.5L 7/1996 - 8/2004



Core Height	375mm	Core Width	655mm
Core Thickness	16mm 1 Row	Inlet / Outlet	35 / 35
Oil Cooler	N/A		
Condenser	CNX083	Receiver Drier	RDX608

Notes:

J27CA

To suit Mitsubishi Mirage CE
4 cyl 1.5L 7/1996 - 8/2004



Core Height	375mm	Core Width	660mm
Core Thickness	16mm 1 Row	Inlet / Outlet	35 / 35
Oil Cooler	300mm		
Condenser	CNX089	Receiver Drier	RDX608

Notes:

J51CA

To suit Mitsubishi Nimbus UG
4 cyl 2.4L 11/1998 - 5/2005



Core Height	450mm	Core Width	718mm
Core Thickness	16mm 1 Row	Inlet / Outlet	36 / 36
Oil Cooler	375mm		
Condenser	CNX8330	Receiver Drier	RDX0040

Notes:

J51CM

To suit Mitsubishi Nimbus UG
4 cyl 2.4L 11/1998 - 5/2005



Core Height	450mm	Core Width	718mm
Core Thickness	16mm 1 Row	Inlet / Outlet	36 / 36
Oil Cooler	N/A		
Condenser	CNX8330	Receiver Drier	RDX0040

Notes:

MIT1857

To suit Mitsubishi Outlander ZE - ZG
4 cyl 2.4L 1/2003 >



Core Height	425mm	Core Width	685mm
Core Thickness	25mm 1 Row	Inlet / Outlet	36 / 36
Oil Cooler	300mm		
Condenser	CNX084	Receiver Drier	RDX624

Notes:

MIT1095

To suit Mitsubishi Outlander ZE - ZG
V6 3.0L 1/2003 >



ALUMINIUM / PLASTIC
AUTOMATIC / MANUAL

Core Height	700mm	Core Width	400mm
Core Thickness	25mm 1 Row	Inlet / Outlet	36 / 36
Oil Cooler	N/A		
Condenser	CNX084	Receiver Drier	RDX624

Notes: External Oil Cooler

J48CM

To suit Mitsubishi Pajero IO
4 cyl 1.6, 1.8 & 2.0L 3/1999 - 4/2003



ALUMINIUM / PLASTIC
MANUAL

Core Height	425mm	Core Width	660mm
Core Thickness	16mm 1 Row	Inlet / Outlet	36 / 36
Oil Cooler	N/A		
Condenser	CNX094	Receiver Drier	

Notes:

MIT45095

To suit Mitsubishi Pajero NM - NT
4 cyl 3.2L Turbo Diesel 5/2002 >



ALUMINIUM / PLASTIC
AUTOMATIC

Core Height	525mm	Core Width	705mm
Core Thickness	24mm 1 Row	Inlet / Outlet	35 / 35
Oil Cooler	390mm		
Condenser	CNX841 / CNX918	Receiver Drier	RDX0050

Notes:

MIT45090

To suit Mitsubishi Pajero NM - NT
V6 3.5 & 3.8L 5/2000 >



ALUMINIUM / PLASTIC
AUTOMATIC

Core Height	501mm	Core Width	708mm
Core Thickness	16mm 1 Row	Inlet / Outlet	35 / 35
Oil Cooler	390mm		
Condenser	CNX841 / CNX918	Receiver Drier	RDX0050

Notes:

J32CM

To suit Mitsubishi Pajero NH - NL
4 cyl 2.8L Turbo Diesel & V6 3.0L 5/1991 - 5/2000



COPPER / PLASTIC
MANUAL

Core Height	500mm	Core Width	602mm
Core Thickness	40mm 3 Row	Inlet / Outlet	36 / 36
Oil Cooler	N/A		
Condenser	CNX2100 / CNX5150	Receiver Drier	RDX281

Notes: Condenser options CNX2100 (2.8 DSL) CNX5150 (3.0L V6)

J33CM

To suit Mitsubishi Pajero NH - NL
V6 3.0 & 3.5L 5/1991 - 5/2000



COPPER / BRASS
MANUAL

Core Height	470mm	Core Width	600mm
Core Thickness	32mm 3 Row	Inlet / Outlet	35 / 35
Oil Cooler	N/A		
Condenser	CNX2120 / CNX5150	Receiver Drier	RDX281

Notes: Condenser options CNX2120 (3.5L V6) CNX5150 (3.0L V6)

MIT1124

To suit Mitsubishi Pajero NF - NJ
V6 3.0L 8/1988 - 12/1993



Core Height	425mm	Core Width	600mm
Core Thickness	32mm 2 Row	Inlet / Outlet	35 / 35
Oil Cooler	300mm		
Condenser	CNX305	Receiver Drier	RDX022

Notes:

MIT41013

To suit Mitsubishi RVR
4 cyl 2.0L 1/1991 - 12/1998



Core Height	376mm	Core Width	660mm
Core Thickness	32mm 2 Row	Inlet / Outlet	36 / 36
Oil Cooler	350mm		
Condenser	CNX085	Receiver Drier	RDX603

Notes:

MIT44540

To suit Mitsubishi Starwagon SJ WA
4 cyl 2.0 & 2.4L, V6 3.0L 10/1994 - 2004



Core Height	505mm	Core Width	585mm
Core Thickness	24mm 1 Row	Inlet / Outlet	36 / 36
Oil Cooler	300mm		
Condenser		Receiver Drier	RDX608

Notes: 8.5mm Tube Pitch

MIT44542

To suit Mitsubishi Starwagon SJ WA
4 cyl 2.0 & 2.4L, V6 3.0L 10/1994 - 2004



Core Height	505mm	Core Width	585mm
Core Thickness	24mm 1 Row	Inlet / Outlet	36 / 36
Oil Cooler	N/A		
Condenser		Receiver Drier	

Notes: 8.5mm Tube Pitch

MIT44501

To suit Mitsubishi Starwagon SF - SJ
4 cyl 2.0, 2.4L 10/1986 - 7/2001



Core Height	400mm	Core Width	590mm
Core Thickness	45mm 3 Row	Inlet / Outlet	36 / 36
Oil Cooler	N/A		
Condenser		Receiver Drier	RDX608

Notes:

MIT44527

To suit Mitsubishi Starwagon SF - SH
4 cyl 2.0 & 2.4L 10/1986 - 9/1994



Core Height	392mm	Core Width	587mm
Core Thickness	32mm 1 Row	Inlet / Outlet	35 / 35
Oil Cooler	N/A		
Condenser		Receiver Drier	RDX608

Notes:

MIT44525

To suit Mitsubishi Starwagon SF - SH
4 cyl 2.0 & 2.4L 10/1986 - 9/1994



COPPER / BRASS
MANUAL

Core Height	400mm	Core Width	587mm
Core Thickness	45mm 3 Row	Inlet / Outlet	34 / 34
Oil Cooler	N/A		
Condenser		Receiver Drier	RDX608

Notes:

MIT44500

To suit Mitsubishi Starwagon SB - SE
4 cyl 1.8L 10/1982 - 10/1986



COPPER / BRASS
MANUAL

Core Height	348mm	Core Width	490mm
Core Thickness	32mm 2 Row	Inlet / Outlet	36 / 37
Oil Cooler	N/A		
Condenser		Receiver Drier	RDX022

Notes:

J59CA

To suit Mitsubishi Triton ML
V6 3.5L 1/2006 >



ALUMINIUM / PLASTIC
AUTOMATIC

Core Height	525mm	Core Width	630mm
Core Thickness	16mm 1 Row	Inlet / Outlet	35 / 35
Oil Cooler	380mm		
Condenser	CNX820	Receiver Drier	RDX610

Notes:

J58CM

To suit Mitsubishi Triton ML
4 cyl 2.4L, V6 3.5L 1/2006 >



ALUMINIUM / PLASTIC
MANUAL

Core Height	525mm	Core Width	635mm
Core Thickness	16mm 1 Row	Inlet / Outlet	35 / 35
Oil Cooler	N/A		
Condenser	CNX820	Receiver Drier	RDX610

Notes:

J57CA

To suit Mitsubishi Triton ML
4 cyl 3.2L Turbo Diesel 1/2006 >



ALUMINIUM / PLASTIC
AUTOMATIC

Core Height	525mm	Core Width	633mm
Core Thickness	26mm 1 Row	Inlet / Outlet	38 / 38
Oil Cooler	350mm		
Condenser	CNX819	Receiver Drier	RDX610

Notes:

J57CM

To suit Mitsubishi Triton ML
4 cyl 3.2L Turbo Diesel 1/2006 >



ALUMINIUM / PLASTIC
MANUAL

Core Height	525mm	Core Width	630mm
Core Thickness	27mm 1 Row	Inlet / Outlet	35 / 35
Oil Cooler	N/A		
Condenser	CNX819	Receiver Drier	RDX610

Notes:

J58CA

To suit Mitsubishi Triton ML
4 cyl 2.4L 1/2006 >



ALUMINIUM /
PLASTIC
AUTOMATIC

Core Height	525mm	Core Width	630mm
Core Thickness	16mm 1 Row	Inlet / Outlet	35 / 35
Oil Cooler	N/A		
Condenser		Receiver Drier	

Notes: Bottom Fitting at 90°

MIT43022

To suit Mitsubishi Triton MK
4 cyl 2.8L Diesel inc Turbo 1/1996 - 4/2007



COPPER / PLASTIC
MANUAL

Core Height	425mm	Core Width	610mm
Core Thickness	45mm 3 Row	Inlet / Outlet	35 / 35
Oil Cooler	N/A		
Condenser	CNX092 / CNX087 / CNX095	Receiver Drier	RDX608

Notes: Condenser options CNX092 (96-01) CNX087 (01-02) CNX095 (02->)

MIT2702

To suit Mitsubishi Triton MK
4 cyl 2.5L Diesel 10/1996 - 4/2007



ALUMINIUM / PLASTIC
MANUAL

Core Height	375mm	Core Width	598mm
Core Thickness	26mm 1 Row	Inlet / Outlet	35 / 35
Oil Cooler	N/A		
Condenser	CNX087 / CNX095	Receiver Drier	RDX608

Notes: Condenser options CNX092 (96-01) CNX087 (01-02) CNX095 (02->)

MIT1692

To suit Mitsubishi Triton MK
4 cyl 2.4L Petrol & 2.8L Diesel 1/1996 - 2003



ALUMINIUM / PLASTIC
MANUAL

Core Height	375mm	Core Width	595mm
Core Thickness	32mm 1 Row	Inlet / Outlet	35 / 35
Oil Cooler	N/A		
Condenser	CNX087 / CNX095	Receiver Drier	RDX608

Notes:

MIT45020

To suit Mitsubishi Triton MK
4 cyl 2.4L Petrol & 2.8L Turbo Diesel
10/1996 - 4/2007



ALUMINIUM / PLASTIC
AUTOMATIC

Core Height	500mm	Core Width	642mm
Core Thickness	32mm 2 Row	Inlet / Outlet	37 / 37
Oil Cooler	350mm		
Condenser	CNX087 / CNX095	Receiver Drier	RDX608

Notes: 8.5mm Tube Pitch

MIT45021

To suit Mitsubishi Triton MK
4 cyl 2.4L Petrol & 2.8L Turbo Diesel
10/1996 - 4/2007



ALUMINIUM / PLASTIC
MANUAL

Core Height	500mm	Core Width	642mm
Core Thickness	32mm 2 Row	Inlet / Outlet	37 / 37
Oil Cooler	350mm		
Condenser	CNX087 / CNX095	Receiver Drier	RDX608

Notes: 8.5mm Tube Pitch

MIT43016

To suit Mitsubishi Triton MH - MJ
V6 3.0L 9/1990 - 10/1996



COPPER / BRASS
MANUAL

Core Height	400mm	Core Width	590mm
Core Thickness	32mm 2 Row	Inlet / Outlet	36 / 36
Oil Cooler	N/A		
Condenser	CNX402	Receiver Drier	RDX022

Notes:

MIT43012

To suit Mitsubishi Triton ME - MJ
4 cyl 2.6L 10/1986 - 10/1996



COPPER / PLASTIC
MANUAL

Core Height	425mm	Core Width	595mm
Core Thickness	32mm 2 Row	Inlet / Outlet	36 / 36
Oil Cooler	N/A		
Condenser	CNX305	Receiver Drier	RDX030

Notes:

J31CA

To suit Mitsubishi Triton ME - MJ
4 cyl 2.6L 10/1986 - 10/1996



COPPER / BRASS
AUTOMATIC

Core Height	397mm	Core Width	598mm
Core Thickness	30mm 2 Row	Inlet / Outlet	36 / 36
Oil Cooler	350mm		
Condenser	CNX305	Receiver Drier	RDX030

Notes:

MIT43010

To suit Mitsubishi Triton ME - MJ
4 cyl 2.6L 10/1986 - 10/1996



COPPER / BRASS
AUTOMATIC

Core Height	397mm	Core Width	598mm
Core Thickness	16mm 1 Row	Inlet / Outlet	36 / 36
Oil Cooler	345mm		
Condenser	CNX305	Receiver Drier	RDX030

Notes:

J40CM

To suit Mitsubishi Triton ME - MJ
4 cyl 2.5L Diesel inc Turbo 10/1986 - 10/1996



COPPER / BRASS
MANUAL

Core Height	425mm	Core Width	600mm
Core Thickness	32mm 2 Row	Inlet / Outlet	36 / 36
Oil Cooler	N/A		
Condenser	CNX305	Receiver Drier	RDX030

Notes:

J15CA

To suit Mitsubishi Verada KE - KW
V6 3.5L 10/1996 - 5/2006



ALUMINIUM / PLASTIC
AUTOMATIC

Core Height	400mm	Core Width	718mm
Core Thickness	27mm 2 Row	Inlet / Outlet	36 / 36
Oil Cooler	375mm		
Condenser	CNX080	Receiver Drier	RDX603

Notes:

MIT42030

To suit Mitsubishi Verada KE - KW
V6 3.5L 10/1996 - 5/2006



ALUMINIUM / PLASTIC
AUTOMATIC

Core Height	400mm	Core Width	718mm
Core Thickness	24mm 1 Row	Inlet / Outlet	35 / 35
Oil Cooler	375mm		
Condenser	CNX080	Receiver Drier	RDX603

Notes:

15-MIT42030

To suit Mitsubishi Verada KE - KW
V6 3.5L 10/1996 - 5/2006



ALUMINIUM / PLASTIC
AUTOMATIC

Core Height	400mm	Core Width	718mm
Core Thickness	24mm 1 Row	Inlet / Outlet	35 / 35
Oil Cooler	375mm		
Condenser	CNX080	Receiver Drier	RDX603

Notes:

MIT42020

To suit Mitsubishi Verada KR - KS
V6 3.0L 8/1991 - 10/1997

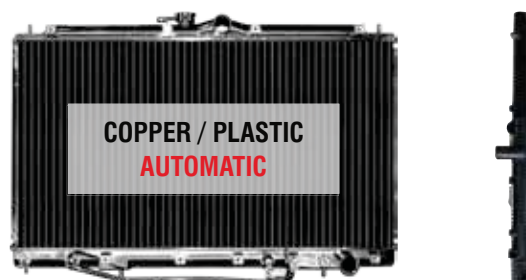

COPPER / PLASTIC
AUTOMATIC

Core Height	398mm	Core Width	727mm
Core Thickness	38mm 2 Row	Inlet / Outlet	35 / 35
Oil Cooler	375mm		
Condenser	CNX076	Receiver Drier	RDX282

Notes:

MORRIS-1

To suit Morris 850 - 1275
4 cyl 0.8, 1.1 & 1.3L 1/1962 - 3/1974



COPPER / BRASS
MANUAL

Core Height	266mm	Core Width	263mm
Core Thickness	32mm 2 Row	Inlet / Outlet	27 / 27
Oil Cooler	N/A		
Condenser		Receiver Drier	

Notes:

MORRIS-2

To suit Morris 850 - 1275
4 cyl 0.8, 1.1 & 1.3L 1/1962 - 3/1975



COPPER / BRASS
MANUAL

Core Height	266mm	Core Width	263mm
Core Thickness	32mm 2 Row	Inlet / Outlet	27 / 27
Oil Cooler	N/A		
Condenser		Receiver Drier	

Notes:

NIS1213

To suit Nissan 180SX, 200SX, S14,
S15, SR20D
4 cyl 2.0L Turbo 10/1994 - 2/2003



ALUMINIUM / PLASTIC
AUTOMATIC

Core Height	360mm	Core Width	648mm
Core Thickness	16mm 1 Row	Inlet / Outlet	37 / 37
Oil Cooler	350mm		
Condenser	CNX565 / CNX564	Receiver Drier	RDX610

Notes: Condenser option CNX565 (10/98 - 00) CNX564 (98>)

NIS42005

To suit Nissan 300ZX, Z31
V6 3.0L inc Turbo 5/1984 - 10/1986



ALUMINIUM / PLASTIC
AUTOMATIC

Core Height	502mm	Core Width	458mm
Core Thickness	24mm 1 Row	Inlet / Outlet	36 / 36
Oil Cooler	250mm		
Condenser		Receiver Drier	

Notes:

NIS1182

To suit Nissan 300ZX, Z32 Targa
V6 3.0L 1990 - 1996



ALUMINIUM / PLASTIC
AUTOMATIC

Core Height	400mm	Core Width	691mm
Core Thickness	16mm 1 Row	Inlet / Outlet	35 / 35
Oil Cooler	300mm		
Condenser		Receiver Drier	

Notes:

NIS42007

To suit Nissan 350Z, Z33
V6 3.5L 2/2003 - 5/2010



ALUMINIUM / PLASTIC
AUTOMATIC

Core Height	400mm	Core Width	735mm
Core Thickness	24mm 1 Row	Inlet / Outlet	36 / 36
Oil Cooler	375mm		
Condenser	CNX827	Receiver Drier	RDX627

Notes:

NIS42008

To suit Nissan 350Z, Z33
V6 3.5L 2/2003 - 5/2010



ALUMINIUM / PLASTIC
MANUAL

Core Height	400mm	Core Width	735mm
Core Thickness	24mm 1 Row	Inlet / Outlet	36 / 36
Oil Cooler	N/A		
Condenser	CNX827	Receiver Drier	RDX627

Notes:

NIS41020

To suit Nissan 720
4 cyl 1.8L 1/1980 - 1/1986



COPPER / BRASS
MANUAL

Core Height	330mm	Core Width	545mm
Core Thickness	45mm 3 Row	Inlet / Outlet	38 / 38
Oil Cooler	N/A		
Condenser		Receiver Drier	

Notes:

NIS40085

To suit Nissan Bluebird SR18DE
4 cyl 1.8L 1/1995 - 12/1998 (NZ)



ALUMINIUM / PLASTIC
AUTOMATIC

Core Height	378mm	Core Width	688mm
Core Thickness	24mm 1 Row	Inlet / Outlet	38 / 39
Oil Cooler	300mm		
Condenser	CNX524	Receiver Drier	RDX605

Notes:

NIS40035

To suit Nissan Bluebird SR18DI
4 cyl 1.8L 1/1989 - 12/1991 (NZ)



ALUMINIUM / PLASTIC
AUTOMATIC

Core Height	380mm	Core Width	695mm
Core Thickness	24mm 1 Row	Inlet / Outlet	38 / 38
Oil Cooler	300mm		
Condenser	CNX017	Receiver Drier	RDX033

Notes:

F17CA

To suit Nissan Bluebird U13 KA24
4 cyl 2.4L 9/1993 - 12/1997



ALUMINIUM / PLASTIC
AUTOMATIC

Core Height	320mm	Core Width	650mm
Core Thickness	16mm 1 Row	Inlet / Outlet	28 / 28
Oil Cooler	200mm		
Condenser	CNX524	Receiver Drier	RDX605

Notes:

NIS40085

To suit Nissan Bluebird U13 SR18DE
4 cyl 2.4L 9/1993 - 12/1997



ALUMINIUM / PLASTIC
AUTOMATIC

Core Height	378mm	Core Width	688mm
Core Thickness	24mm 1 Row	Inlet / Outlet	38 / 39
Oil Cooler	300mm		
Condenser	CNX524	Receiver Drier	RDX605

Notes:

F16CA

To suit Nissan Cefiro
V6 2.0L 1/1994 - 12/1998 (NZ)



ALUMINIUM / PLASTIC
AUTOMATIC

Core Height	400mm	Core Width	700mm
Core Thickness	28mm 1 Row	Inlet / Outlet	36 / 36
Oil Cooler	300mm		
Condenser	CNX525	Receiver Drier	RDX605

Notes:

NIS42015

To suit Nissan Cefiro
V6 2.0L 1/1994 - 12/1998 (NZ)



ALUMINIUM / PLASTIC
AUTOMATIC

Core Height	400mm	Core Width	688mm
Core Thickness	24mm 1 Row	Inlet / Outlet	35 / 35
Oil Cooler	300mm		
Condenser	CNX525	Receiver Drier	RDX605

Notes:

NIS1234

To suit Nissan Dualis J10
4 cyl 2.0L 10/2007 >



ALUMINIUM / PLASTIC
CVT & MANUAL

Core Height	590mm	Core Width	433mm
Core Thickness	27mm 1 Row	Inlet / Outlet	35 / 35
Oil Cooler	N/A		
Condenser		Receiver Drier	

Notes: External Oil Cooler

NIS40045

To suit Nissan Lucino
4 cyl 1.5L 1/1994 - 12/1999 (NZ)



ALUMINIUM / PLASTIC
AUTOMATIC

Core Height	320mm	Core Width	648mm
Core Thickness	24mm 1 Row	Inlet / Outlet	28 / 28
Oil Cooler	300mm		
Condenser	CNX523	Receiver Drier	RDX223

Notes:

NIS1508

To suit Nissan Maxima J31
V6 3.5L 1/2006 >



ALUMINIUM / PLASTIC
AUTOMATIC

Core Height	400mm	Core Width	730mm
Core Thickness	16mm 1 Row	Inlet / Outlet	36 / 36
Oil Cooler	350mm		
Condenser	CNX451	Receiver Drier	

Notes:

F16CA

To suit Nissan Maxima A33
V6 3.0L 2/1995 - 12/2003



ALUMINIUM / PLASTIC
AUTOMATIC

Core Height	400mm	Core Width	700mm
Core Thickness	28mm 1 Row	Inlet / Outlet	36 / 36
Oil Cooler	300mm		
Condenser	CNX525	Receiver Drier	RDX605

Notes:

NIS42015

To suit Nissan Maxima A32 A33
V6 3.0L 2/1995 - 12/2003



ALUMINIUM / PLASTIC
AUTOMATIC

Core Height	400mm	Core Width	688mm
Core Thickness	24mm 1 Row	Inlet / Outlet	35 / 35
Oil Cooler	300mm		
Condenser	CNX525	Receiver Drier	RDX605

Notes:

NIS42010

To suit Nissan Maxima J30
V6 3.0L 4/1990 - 1/1996



ALUMINIUM / PLASTIC
AUTOMATIC

Core Height	400mm	Core Width	688mm
Core Thickness	24mm 1 Row	Inlet / Outlet	36 / 36
Oil Cooler	300mm	Receiver Drier	RDX605 (93-94)
Condenser	CNX530	Receiver Drier	RDX228 (90-92)

Notes:

NIS42000

To suit Nissan Maxima J30
V6 3.0L 4/1990 - 2/1995



COPPER / BRASS
AUTOMATIC

Core Height	400mm	Core Width	677mm
Core Thickness	32mm 2 Rows	Inlet / Outlet	36 / 36
Oil Cooler	300mm		
Condenser	CNX530	Receiver Drier	RDX220

Notes:

NIS1233

To suit Nissan Micra K12
4 cyl 1.4L 10/2007 >



Core Height	380mm	Core Width	445mm
Core Thickness	16mm 1 Row	Inlet / Outlet	35 / 35
Oil Cooler	200mm		
Condenser		Receiver Drier	

Notes:

NIS41060

To suit Nissan Murano Z50 Z51
V6 3.5L 1/2005 >



Core Height	455mm	Core Width	740mm
Core Thickness	24mm 1 Row	Inlet / Outlet	34 / 34
Oil Cooler	375mm		
Condenser	CNX534	Receiver Drier	

Notes:

NIS1507

To suit Nissan Navara D40
V6 4.0L 12/2005 >



Core Height	600mm	Core Width	685mm
Core Thickness	36mm 1 Row	Inlet / Outlet	35 / 35
Oil Cooler	425mm		
Condenser	CNX824	Receiver Drier	

Notes:

NIS1506

To suit Nissan Navara D40
V6 4.0L 12/2005 >



Core Height	600mm	Core Width	685mm
Core Thickness	36mm 1 Row	Inlet / Outlet	35 / 35
Oil Cooler	N/A		
Condenser	CNX824	Receiver Drier	

Notes:

NIS1505

To suit Nissan Navara D40
4 cyl 2.5L Turbo Diesel 5/2005 >



Core Height	600mm	Core Width	685mm
Core Thickness	32mm 1 Row	Inlet / Outlet	35 / 35
Oil Cooler	425mm		
Condenser	CNX824	Receiver Drier	

Notes:

NIS1504

To suit Nissan Navara D40
4 cyl 2.5L Turbo Diesel 5/2005 >



Core Height	600mm	Core Width	685mm
Core Thickness	36mm 1 Row	Inlet / Outlet	35 / 35
Oil Cooler	N/A		
Condenser	CNX824	Receiver Drier	

Notes:

NIS41015

To suit Nissan Navara D22
V6 3.3L 2/2003 - 7/2006



ALUMINIUM / PLASTIC
AUTOMATIC

Core Height	502mm	Core Width	688mm
Core Thickness	24mm 1 Row	Inlet / Outlet	36 / 36
Oil Cooler	375mm		
Condenser	CNX546	Receiver Drier	RDX232

Notes:

NIS1826

To suit Nissan Navara D22
4 cyl 2.7L Diesel 1998 - 2000



ALUMINIUM / PLASTIC
AUTOMATIC

Core Height	450mm	Core Width	686mm
Core Thickness	36mm 2 Row	Inlet / Outlet	36 / 36
Oil Cooler	300mm		
Condenser	CNX539	Receiver Drier	RDX610

Notes:

NIS41038

To suit Nissan Navara D22
4 cyl 2.4L & V6 3.0L 3/1997 - 12/2005



ALUMINIUM / PLASTIC
AUTOMATIC

Core Height	448mm	Core Width	688mm
Core Thickness	32mm 1 Row	Inlet / Outlet	36 / 36
Oil Cooler	375mm		
Condenser	CNX520	Receiver Drier	RDX033

Notes:

NIS41040

To suit Nissan Navara D22
4 cyl 2.4L & V6 3.0L 3/1997 - 12/2005



ALUMINIUM / PLASTIC
MANUAL

Core Height	448mm	Core Width	688mm
Core Thickness	32mm 1 Row	Inlet / Outlet	36 / 36
Oil Cooler	N/A		
Condenser	CNX520	Receiver Drier	RDX033

Notes:

NIS1783

To suit Nissan Navara D22
4 cyl 2.5, 2.7, 3.0 & 3.2L Diesel inc Turbo
3/1997 - 2001



ALUMINIUM / PLASTIC
MANUAL

Core Height	448mm	Core Width	691mm
Core Thickness	25mm 1 Row	Inlet / Outlet	35 / 35
Oil Cooler	N/A		
Condenser	CNX539	Receiver Drier	RDX610

Notes:

NIS1339

To suit Nissan Navara D21
4 cyl 2.7L Diesel 1/1988 - 3/1998



COPPER / PLASTIC
MANUAL

Core Height	429mm	Core Width	648mm
Core Thickness	32mm 2 Row	Inlet / Outlet	36 / 36
Oil Cooler	N/A		
Condenser	CNX520	Receiver Drier	RDX033

Notes: Bottom Dowels Offset to Grill Side

NIS41001

To suit Nissan Navara D21, D22
4 cyl 2.0 & 2.4L & V6 3.0L 1/1986 - 3/1998



Core Height	430mm	Core Width	635mm
Core Thickness	32mm 2 Row	Inlet / Outlet	36 / 36
Oil Cooler	300mm		
Condenser	CNX520	Receiver Drier	RDX033

Notes:

NIS41004

To suit Nissan Navara D21, D22
4 cyl 2.0 & 2.4L & V6 3.0L 1/1986 - 3/1998



Core Height	425mm	Core Width	648mm
Core Thickness	24mm 1 Row	Inlet / Outlet	35 / 35
Oil Cooler	298mm		
Condenser	CNX520	Receiver Drier	RDX033

Notes:

F17CA

To suit Nissan NX, NXR, SR20DE
4 cyl 2.0L 10/1991 - 9/2005



Core Height	320mm	Core Width	650mm
Core Thickness	16mm 1 Row	Inlet / Outlet	28 / 28
Oil Cooler	200mm		
Condenser	CNX524	Receiver Drier	RDX605

Notes:

NIS1507

To suit Nissan Pathfinder R51
V6 4.0L 7/2005 >



Core Height	600mm	Core Width	685mm
Core Thickness	36mm 1 Row	Inlet / Outlet	35 / 35
Oil Cooler	425mm		
Condenser	CNX824	Receiver Drier	

Notes:

NIS1506

To suit Nissan Pathfinder R51
V6 4.0L 7/2005 >



Core Height	600mm	Core Width	685mm
Core Thickness	36mm 1 Row	Inlet / Outlet	35 / 35
Oil Cooler	N/A		
Condenser	CNX824	Receiver Drier	

Notes:

NIS1505

To suit Nissan Pathfinder R51
4 cyl 2.5L Turbo Diesel 7/2005 >



Core Height	600mm	Core Width	685mm
Core Thickness	32mm 1 Row	Inlet / Outlet	35 / 35
Oil Cooler	425mm		
Condenser	CNX824	Receiver Drier	

Notes:

NIS41015

To suit Nissan Pathfinder R50
V6 3.3L 11/1995 - 7/2005



ALUMINIUM / PLASTIC
AUTOMATIC

Core Height	502mm	Core Width	688mm
Core Thickness	24mm 1 Row	Inlet / Outlet	36 / 36
Oil Cooler	375mm		
Condenser	CNX546	Receiver Drier	RDX232

Notes:

NIS41001

To suit Nissan Pathfinder D21
4 cyl 2.4L & V6 3.0L 12/1986 - 11/1995



COPPER / BRASS
AUTOMATIC

Core Height	430mm	Core Width	635mm
Core Thickness	32mm 2 Row	Inlet / Outlet	36 / 36
Oil Cooler	300mm		
Condenser	CNX520	Receiver Drier	RDX033

Notes:

NIS41004

To suit Nissan Pathfinder D21
4 cyl 2.4L & V6 3.0L 12/1986 - 11/1995



ALUMINIUM / PLASTIC
AUTOMATIC

Core Height	425mm	Core Width	648mm
Core Thickness	24mm 1 Row	Inlet / Outlet	35 / 35
Oil Cooler	298mm		
Condenser	CNX520	Receiver Drier	RDX033

Notes:

NIS2260

To suit Nissan Patrol GU Y61
4 & 6 cyl 3.0L Diesel & 4.2L inc Turbo 10/2004 >



ALUMINIUM / PLASTIC
AUTOMATIC

Core Height	450mm	Core Width	910mm
Core Thickness	34mm 2 Row	Inlet / Outlet	35 / 35
Oil Cooler	375mm		
Condenser	CNX533 / CNX579	Receiver Drier	RDX232 / RDX626

Notes: 13mm Return Pipe on D/S. Overflow Pipe to P/S

NIS2259

To suit Nissan Patrol GU Y61
4 & 6 cyl 3.0 & 4.2L Turbo Diesel 10/2004 >



ALUMINIUM / PLASTIC
MANUAL

Core Height	450mm	Core Width	910mm
Core Thickness	34mm 2 Row	Inlet / Outlet	35 / 35
Oil Cooler	N/A		
Condenser	CNX533 / CNX579	Receiver Drier	RDX232 / RDX626

Notes: 13mm Return Pipe D/S, Overflow Pipe to P/S

NIS2044

To suit Nissan Patrol GU Y61
6 cyl 4.8L 10/2004 >



ALUMINIUM / PLASTIC
AUTOMATIC

Core Height	630mm	Core Width	588mm
Core Thickness	36mm 2 Row	Inlet / Outlet	35 / 35
Oil Cooler	375mm		
Condenser	CNX533 / CNX579	Receiver Drier	RDX232 / RDX626

Notes:

NIS2735

To suit Nissan Patrol GU Y61
6 cyl 4.8L 10/2001 >



ALUMINIUM /
PLASTIC
MANUAL



Core Height	630mm	Core Width	588mm
Core Thickness	36mm 1 Row	Inlet / Outlet	35 / 35
Oil Cooler	N/A		
Condenser	CNX533 / CNX579	Receiver Drier	RDX232 / RDX626

Notes: Overflow Pipe to D/S

NIS2790

To suit Nissan Patrol GU Y61
6 cyl 4.8L 10/2001 >



ALUMINIUM /
PLASTIC
AUTOMATIC



Core Height	630mm	Core Width	588mm
Core Thickness	36mm 2 Rows	Inlet / Outlet	35 / 35
Oil Cooler	N/A		
Condenser	CNX533 / CNX579	Receiver Drier	RDX232 / RDX626

Notes: 13mm Bleeder Pipe D/S, No Overflow Pipe

NIS2810

To suit Nissan Patrol GU Y61
6 cyl 4.2L Diesel 2001 >



ALUMINIUM /
PLASTIC
MANUAL



Core Height	630mm	Core Width	588mm
Core Thickness	36mm 2 Rows	Inlet / Outlet	35 / 35
Oil Cooler	N/A		
Condenser	CNX533 / CNX579	Receiver Drier	RDX232 / RDX626

Notes: 13 mm Return Pipe P/S, No Overflow Pipe

NIS2813

To suit Nissan Patrol GU Y61
6 cyl 4.2L Diesel 2001 >



ALUMINIUM /
PLASTIC
AUTOMATIC



Core Height	630mm	Core Width	588mm
Core Thickness	36mm 1 Row	Inlet / Outlet	35 / 35
Oil Cooler	375mm		
Condenser	CNX533 / CNX579	Receiver Drier	RDX232 / RDX626

Notes: Overflow Pipe D/S

NIS2811

To suit Nissan Patrol GU Y61
6 cyl 4.2L Diesel 2001 >



ALUMINIUM /
PLASTIC
AUTOMATIC



Core Height	630mm	Core Width	588mm
Core Thickness	36mm 2 Row	Inlet / Outlet	35 / 35
Oil Cooler	375mm		
Condenser	CNX533 / CNX579	Receiver Drier	RDX232 / RDX626

Notes:

NIS4045

To suit Nissan Patrol GU Y61
4 cyl 3.0L Turbo Diesel 10/2001 - 1/2009
Heavy Duty



COPPER / BRASS
AUTOMATIC



Core Height	450mm	Core Width	906mm
Core Thickness	48mm 3 Rows	Inlet / Outlet	35 / 35
Oil Cooler	375mm		
Condenser	CNX533 / CNX579	Receiver Drier	RDX232 / RDX626

Notes: 13mm Bleeder Pipe on D/S, No Overflow Pipe

NIS4046

To suit Nissan Patrol GU Y61
4 cyl 3.0L Turbo Diesel 10/2001 - 1/2009
Heavy Duty



COPPER / BRASS
MANUAL

Core Height	450mm	Core Width	906mm
Core Thickness	48mm 3 Rows	Inlet / Outlet	35 / 35
Oil Cooler	N/A		
Condenser	CNX533 / CNX579	Receiver Drier	RDX232 / RDX626

Notes: 13mm Bleeder Pipe on D/S, No Overflow Pipe

NIS4042

To suit Nissan Patrol GU Y61 TD42
6 cyl 4.2L Diesel inc Turbo 4/1998 - 4/2007
Heavy Duty



COPPER / BRASS
MANUAL

Core Height	450mm	Core Width	906mm
Core Thickness	48mm 3 Rows	Inlet / Outlet	35 / 35
Oil Cooler	N/A		
Condenser	CNX533 / CNX579	Receiver Drier	RDX232 / RDX626

Notes: 8mm Bleeder Pipe on D/S. Overflow Pipe in filler neck

NIS4039

To suit Nissan Patrol GU Y61 SI & II TB45E
6 cyl 4.5L Petrol 12/1997 - 10/2001
Heavy Duty



COPPER / BRASS
MANUAL

Core Height	450mm	Core Width	906mm
Core Thickness	48mm 3 Rows	Inlet / Outlet	35 / 35
Oil Cooler	N/A		
Condenser	CNX533 / CNX579	Receiver Drier	RDX626 / RDX232

Notes: 8mm Bleeder Pipe on P/S. Overflow Pipe in filler neck

NIS4040

To suit Nissan Patrol GU Y61 SI & II TB45E
6 cyl 4.5L Petrol 12/1997 - 10/2001
Heavy Duty

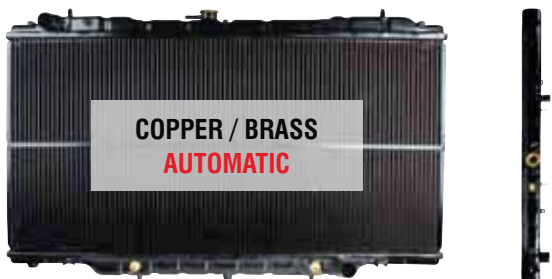

COPPER / BRASS
AUTOMATIC

Core Height	450mm	Core Width	906mm
Core Thickness	48mm 3 Rows	Inlet / Outlet	35 / 35
Oil Cooler	375mm		
Condenser	CNX533 / CNX579	Receiver Drier	RDX232 / RDX626

Notes: 8mm Bleeder Pipe on P/S. Overflow Pipe in filler neck

NIS2262

To suit Nissan Patrol GU Y61
6 cyl 4.5L Petrol 12/1997 - 10/2001



ALUMINIUM / PLASTIC
AUTOMATIC

Core Height	450mm	Core Width	910mm
Core Thickness	34mm 2 Row	Inlet / Outlet	35 / 35
Oil Cooler	375mm		
Condenser	CNX533 / CNX579	Receiver Drier	RDX232 / RDX626

Notes: 2 x Sender Port B/T, Overflow Pipe To P/S

NIS2261

To suit Nissan Patrol GU Y61
6 cyl 4.5L Petrol 12/1997 - 10/2001



ALUMINIUM / PLASTIC
MANUAL

Core Height	450mm	Core Width	910mm
Core Thickness	34mm 2 Row	Inlet / Outlet	35 / 35
Oil Cooler	N/A		
Condenser	CNX533 / CNX579	Receiver Drier	RDX232 / RDX626

Notes: 8mm Return Pipe P/S, Overflow Pipe to P/S, 2 x Sender Port B/T

NIS4026

To suit Nissan Patrol GQ Y60 TD42
6 cyl 4.2L Diesel 1/1988 - 4/1999
Heavy Duty

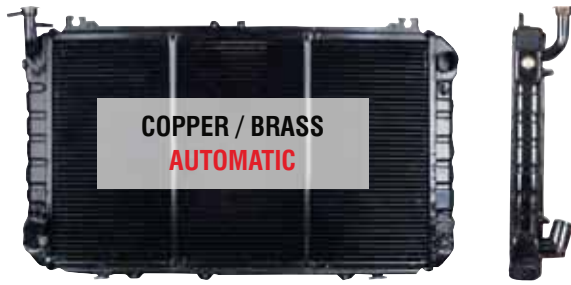

COPPER / BRASS
AUTOMATIC

Core Height	740mm	Core Width	460mm
Core Thickness	55mm	Inlet / Outlet	42 / 42
Oil Cooler	2 x 275mm		
Condenser	CNX022 / CNX023	Receiver Drier	RDX033 / RDX221

Notes: Sensor Ports with Brass plugs in outlet fitting & tank

NIS4025

To suit Nissan Patrol GQ Y60 TD42
6 cyl 4.2L Diesel 1/1988 - 4/1999
Heavy Duty



COPPER / BRASS
MANUAL

Core Height	740mm	Core Width	460mm
Core Thickness	48mm 3 Rows	Inlet / Outlet	41 / 41
Oil Cooler	N/A		
Condenser	CNX022 / CNX023	Receiver Drier	RDX033 / RDX221

Notes: Sensor Ports with Brass plugs in outlet fitting & tank

NIS41005

To suit Nissan Patrol GQ Y60 TB42
6 cyl 4.2L Petrol 1/1998 - 4/1999



COPPER / BRASS
MANUAL

Core Height	738mm	Core Width	455mm
Core Thickness	35mm 2 Row	Inlet / Outlet	36 / 41
Oil Cooler	N/A		
Condenser	CNX022 / CNX535	Receiver Drier	RDX089 / RDX605

Notes: Condenser options (IMPERIAL FITTINGS) CNX535 (Y60 PF COND)

NIS41007

To suit Nissan Patrol GQ Y60 TD42
6 cyl 4.2L Diesel 1/1998 - 4/1999



COPPER / BRASS
MANUAL

Core Height	738mm	Core Width	455mm
Core Thickness	35mm 2 Row	Inlet / Outlet	41 / 41
Oil Cooler	N/A		
Condenser	CNX022 / CNX535	Receiver Drier	RDX089 / RDX605

Notes:

NIS4030

To suit Nissan Patrol GQ Y60 TB42
6 cyl 4.2L Petrol 1/1992 - 12/1997
Heavy Duty

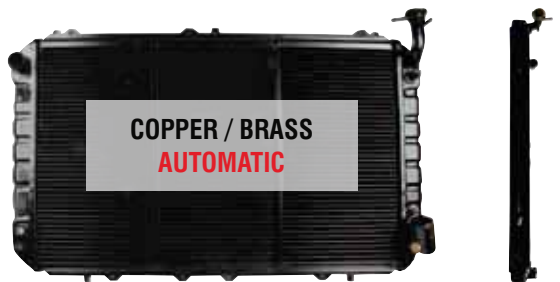

COPPER / BRASS
AUTOMATIC

Core Height	740mm	Core Width	460mm
Core Thickness	48mm 3 Rows	Inlet / Outlet	35 / 40
Oil Cooler	275mm		
Condenser	CNX022 / CNX023	Receiver Drier	RDX033 / RDX221

Notes: Sensor Ports with Brass plugs in outlet fitting & tank

NIS4029

To suit Nissan Patrol GQ Y60 TB42
6 cyl 4.2L Petrol 1/1992 - 12/1997
Heavy Duty



COPPER / BRASS
MANUAL

Core Height	740mm	Core Width	460mm
Core Thickness	48mm 3 Rows	Inlet / Outlet	35 / 40
Oil Cooler	N/A		
Condenser	CNX022 / CNX023	Receiver Drier	RDX033 / RDX221

Notes: Sensor Ports with Brass plugs in outlet fitting & tank

NIS41000

To suit Nissan Patrol MQ SD33
6 cyl 3.3L Diesel inc Turbo 6/1980 - 12/1987



COPPER / BRASS
MANUAL

Core Height	640mm	Core Width	445mm
Core Thickness	49mm 3 Row	Inlet / Outlet	45 / 47
Oil Cooler	N/A		
Condenser		Receiver Drier	

Notes:

NIS41200

To suit Nissan Patrol MK MQ
6 cyl 2.8 & 4.0L 6/1980 - 2/1988

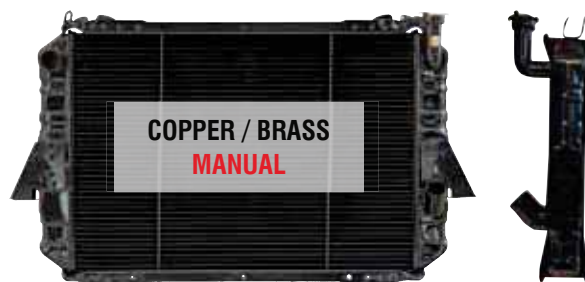

COPPER / BRASS
MANUAL

Core Height	640mm	Core Width	445mm
Core Thickness	49mm 3 Row	Inlet / Outlet	35 / 35
Oil Cooler	N/A		
Condenser		Receiver Drier	

Notes:

NIS40030

To suit Nissan Pintara R31 U12
4 cyl 2.0 & 2.4L 1/1986 - 10/1993



ALUMINIUM / PLASTIC
AUTOMATIC

Core Height	405mm	Core Width	645mm
Core Thickness	32mm 2 Row	Inlet / Outlet	38 / 38
Oil Cooler	300mm		
Condenser		Receiver Drier	RDX033

Notes:

NIS40035

To suit Nissan Pintara R31 U12
4 cyl 2.0 & 2.4L 1/1986 - 10/1993



ALUMINIUM / PLASTIC
AUTOMATIC

Core Height	380mm	Core Width	695mm
Core Thickness	24mm 1 Row	Inlet / Outlet	38 / 38
Oil Cooler	300mm		
Condenser	CNX017	Receiver Drier	RDX033

Notes:

NIS46020

To suit Nissan Pulsar N12
4 cyl 1.3, 1.5 & 1.6L 10/1981 - 5/1988



COPPER / BRASS
MANUAL

Core Height	330mm	Core Width	475mm
Core Thickness	32mm 2 Row	Inlet / Outlet	29 / 29
Oil Cooler	N/A		
Condenser	CNX033	Receiver Drier	RDX027

Notes:

NIS40025

To suit Nissan Pulsar N13 Vector
4 cyl 1.6 & 1.8L 7/1987 - 9/1997



ALUMINIUM / PLASTIC
AUTOMATIC

Core Height	588mm	Core Width	345mm
Core Thickness	24mm 1 Row	Inlet / Outlet	37 / 37
Oil Cooler	180mm		
Condenser	CNX526	Receiver Drier	RDX033

Notes:

NIS46150

To suit Nissan Pulsar N13 Vector
4 cyl 1.6 & 1.8L 7/1987 - 9/1997

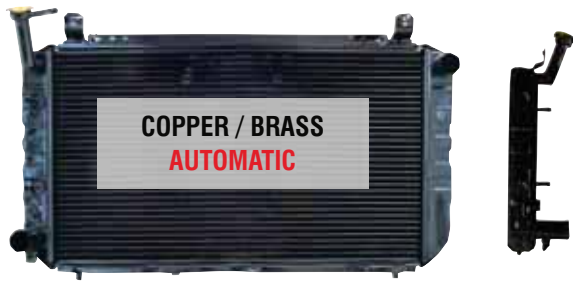

Core Height	590mm	Core Width	345mm
Core Thickness	32mm 2 Row	Inlet / Outlet	36 / 36
Oil Cooler	180mm		
Condenser	CNX526	Receiver Drier	RDX033

Notes:

NIS40045

To suit Nissan Pulsar N14, N15
4 cyl 1.6 & 2.0L 10/1991 - 1/2001

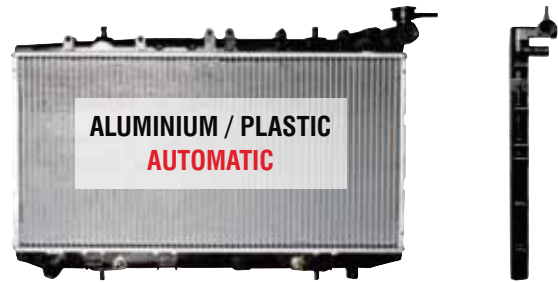

Core Height	320mm	Core Width	648mm
Core Thickness	24mm 1 Row	Inlet / Outlet	28 / 28
Oil Cooler	300mm		
Condenser	CNX523	Receiver Drier	RDX223

Notes:

HOL1106

To suit Nissan Pulsar N14, N15
4 cyl 1.6 & 2.0L 10/1991 - 1/2001



Core Height	320mm	Core Width	645mm
Core Thickness	16mm 1 Row	Inlet / Outlet	35 / 35
Oil Cooler	300mm		
Condenser		Receiver Drier	RDX223

Notes: N14 CNX523, N15 CNX536 / CNX542

NIS40028

To suit Nissan Pulsar N14, N15, SR20DE
4 cyl 2.0L 10/1991 - 1/2001

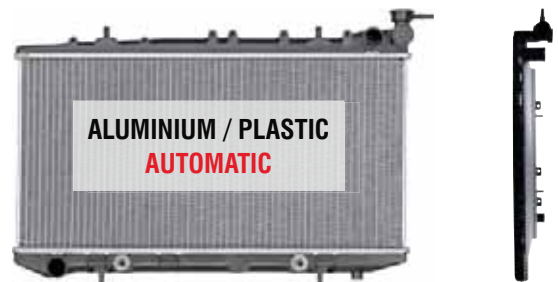

Core Height	320mm	Core Width	645mm
Core Thickness	24mm 1 Row	Inlet / Outlet	35 / 35
Oil Cooler	300mm		
Condenser		Receiver Drier	RDX223

Notes: N14 CNX523, N15 CNX536 / CNX542

NIS40050

To suit Nissan Pulsar N14, N15, N16
4 cyl 1.6 & 1.8L 10/1991 - 2/2004



Core Height	360mm	Core Width	688mm
Core Thickness	24mm 1 Row	Inlet / Outlet	28 / 28
Oil Cooler	298mm		
Condenser	CNX540	Receiver Drier	RDX238

Notes:

NIS40052

To suit Nissan Pulsar N16
4 cyl 1.6 & 1.8L 7/2000 - 2/2006



Core Height	360mm	Core Width	688mm
Core Thickness	24mm 1 Row	Inlet / Outlet	28 / 28
Oil Cooler	N/A		
Condenser	CNX540	Receiver Drier	RDX238 / RDX627

Notes: Condenser options CNX540 (Sedan 2000 - 2003 / Hatch 2001)
Receiver Drier options RDX235 (2000 - 2003 & Hatch 2001)

NIS1130

To suit Nissan Pulsar N16
4 cyl 1.6 & 1.8L 7/2000 - 2/2006



Core Height	360mm	Core Width	695mm
Core Thickness	16mm 1 Row	Inlet / Outlet	28 / 28
Oil Cooler	300mm		
Condenser	CNX540	Receiver Drier	RDX238

Notes: UK Version. 3 Top Fan Mounts

NIS4026

To suit Nissan Safari TD42
6 cyl 4.2L Diesel 1/1987 - 12/1997 (NZ)



Core Height	740mm	Core Width	460mm
Core Thickness	55mm	Inlet / Outlet	42 / 42
Oil Cooler	2 x 275mm		
Condenser		Receiver Drier	

Notes: Oil Cooler fittings included

NIS40045

To suit Nissan Sentra
4 cyl 1.1, 1.5 & 1.6L 1/1991 - 12/1999 (NZ)



Core Height	320mm	Core Width	648mm
Core Thickness	24mm 1 Row	Inlet / Outlet	28 / 28
Oil Cooler	300mm		
Condenser	CNX523	Receiver Drier	RDX223

Notes:

NIS1213

To suit Nissan Silvia SR20DE
4 cyl 2.0L 1/1993 - 12/1998 (NZ)



Core Height	360mm	Core Width	648mm
Core Thickness	16mm 1 Row	Inlet / Outlet	37 / 37
Oil Cooler	350mm		
Condenser	CNX565	Receiver Drier	RDX610

Notes:

NIS1773

To suit Nissan Skyline HR33 GTR, GTS
6 cyl 2.0, 2.5 & 2.6L inc Turbo 1/1992 - 12/1998



Core Height	400mm	Core Width	644mm
Core Thickness	25mm 2 Row	Inlet / Outlet	36 / 36
Oil Cooler	N/A		
Condenser	CNX547	Receiver Drier	

Notes: Sender Port in Bottom Tank

NIS1772

To suit Nissan Skyline HR33 GTR, GTS
6 cyl 2.0, 2.5 & 2.6L inc Turbo 1/1992 - 12/1998



Core Height	400mm	Core Width	645mm
Core Thickness	25mm 2 Row	Inlet / Outlet	36 / 36
Oil Cooler	350mm		
Condenser	CNX547	Receiver Drier	

Notes: Sender Port in Bottom Tank

NIS40030

To suit Nissan Skyline HR31, HR32, R31
6 cyl 2.0 & 3.0L inc Turbo 7/1986 - 3/1994



ALUMINIUM / PLASTIC
AUTOMATIC

Core Height	405mm	Core Width	645mm
Core Thickness	32mm 2 Row	Inlet / Outlet	38 / 38
Oil Cooler	300mm		
Condenser		Receiver Drier	

Notes:

NIS40045

To suit Nissan Sunny
4 cyl 1.5L 1/1994 - 12/1998 (NZ)



ALUMINIUM / PLASTIC
AUTOMATIC

Core Height	320mm	Core Width	648mm
Core Thickness	24mm 1 Row	Inlet / Outlet	28 / 28
Oil Cooler	300mm		
Condenser	CNX523	Receiver Drier	RDX223

Notes:

NIS41015

To suit Nissan Terrano TD27 R20 SII
4 cyl 2.7L Turbo Diesel 1/1993 - 4/2000



ALUMINIUM / PLASTIC
AUTOMATIC

Core Height	502mm	Core Width	688mm
Core Thickness	24mm 1 Row	Inlet / Outlet	36 / 36
Oil Cooler	375mm		
Condenser	CNX546	Receiver Drier	RDX232

Notes:

NIS1956

To suit Nissan Tiida C11
4 cyl 1.8L 2/2006 >



ALUMINIUM / PLASTIC
AUTOMATIC

Core Height	380mm	Core Width	590mm
Core Thickness	16mm 1 Row	Inlet / Outlet	36 / 36
Oil Cooler	300mm		
Condenser		Receiver Drier	

Notes:

NIS40058

To suit Nissan Tiida C11
4 cyl 1.8L 2/2006 >



ALUMINIUM / PLASTIC
MANUAL

Core Height	380mm	Core Width	590mm
Core Thickness	24mm 1 Row	Inlet / Outlet	36 / 36
Oil Cooler	N/A		
Condenser		Receiver Drier	

Notes:

NIS1229

To suit Nissan X-Trail T31 QR25
4 cyl 2.5L Turbo Diesel 10/2007 >



ALUMINIUM / PLASTIC
AUTOMATIC / MANUAL

Core Height	450mm	Core Width	685mm
Core Thickness	16mm 1 Row	Inlet / Outlet	36 / 36
Oil Cooler	N/A		
Condenser	CNX457	Receiver Drier	RDX627

Notes: Uses external oil cooler

NIS41030

To suit Nissan X-Trail T30 SI - III
4 cyl 2.5L 1/2001 - 12/2007



ALUMINIUM / PLASTIC
AUTOMATIC

Core Height	453mm	Core Width	688mm
Core Thickness	24mm 1 Row	Inlet / Outlet	35 / 35
Oil Cooler	350mm		
Condenser	CNX531	Receiver Drier	RDX627

Notes:

NIS41035

To suit Nissan X-Trail T30 SI - III
4 cyl 2.5L 1/2001 - 12/2007



ALUMINIUM / PLASTIC
MANUAL

Core Height	453mm	Core Width	688mm
Core Thickness	24mm 1 Row	Inlet / Outlet	35 / 35
Oil Cooler	N/A		
Condenser	CNX531	Receiver Drier	RDX627

Notes:

PEU17531

To suit Peugeot 206
4 cyl 1.4, 1.6 & 2.0L 10/1999 - 2/2008



ALUMINIUM / PLASTIC
AUTOMATIC & MANUAL

Core Height	380mm	Core Width	540mm
Core Thickness	32mm 1 Row	Inlet / Outlet	32 / 32
Oil Cooler	N/A		
Condenser	CNX567	Receiver Drier	RDX239

Notes:

PEU10261

To suit Peugeot 306
4 cyl 1.8 & 2.0L 4/1994 - 11/2003



ALUMINIUM / PLASTIC
MANUAL

Core Height	640mm	Core Width	398mm
Core Thickness	36mm 2 Row	Inlet / Outlet	40 / 40
Oil Cooler	N/A		
Condenser		Receiver Drier	RDX242

Notes:

PEU17291

To suit Peugeot 306
4 cyl 1.8L Petrol & 1.9 Turbo Diesel
4/1994 - 12/2000



ALUMINIUM / PLASTIC
MANUAL

Core Height	610mm	Core Width	375mm
Core Thickness	24mm 2 Row	Inlet / Outlet	40 / 46
Oil Cooler	N/A		
Condenser	CNX555	Receiver Drier	RDX245 / RDX242

Notes:

PEU67101

To suit Peugeot 307
4 cyl 1.6 & 2.0L Petrol & 2.0 Turbo Diesel
1/2001 - 2/2009



ALUMINIUM / PLASTIC
AUTOMATIC

Core Height	380mm	Core Width	567mm
Core Thickness	32mm 2 Row	Inlet / Outlet	32 / 32
Oil Cooler	N/A		
Condenser	CNX556	Receiver Drier	RDX6333 / RDX0050

Notes: 18mm bypass

PEU19611

To suit Peugeot 405
4 cyl 1.9 & 2.0L 12/1991 - 9/1996



Core Height	610mm	Core Width	378mm
Core Thickness	23mm 1 Row	Inlet / Outlet	40 / 40
Oil Cooler	N/A		
Condenser		Receiver Drier	RDX240

Notes:

PEU16551

To suit Peugeot 405
4 cyl 2.0L Petrol & 1.9 Turbo Diesel
2/1989 - 3/1998



Core Height	610mm	Core Width	370mm
Core Thickness	42mm 1 Row	Inlet / Outlet	40 / 40
Oil Cooler	N/A		
Condenser	CNX552	Receiver Drier	RDX240

Notes:

PEU19601

To suit Peugeot 405
4 cyl 2.0L Petrol & 1.9 Turbo Diesel
2/1989 - 3/1998



Core Height	610mm	Core Width	378mm
Core Thickness	23mm 1 Row	Inlet / Outlet	40 / 40
Oil Cooler	N/A		
Condenser		Receiver Drier	RDX240

Notes:

PEU07251

To suit Peugeot 406
V6 2.9L 9/1997 - 9/2004



Core Height	640mm	Core Width	398mm
Core Thickness	36mm 2 Row	Inlet / Outlet	40 / 40
Oil Cooler	N/A		
Condenser	CNX558	Receiver Drier	

Notes:

CIT19511

To suit Peugeot Partner
4 cyl Petrol & Turbo Diesel 9/2008 >



Core Height	610mm	Core Width	377mm
Core Thickness	23mm 1 Row	Inlet / Outlet	40 / 46
Oil Cooler	N/A		
Condenser		Receiver Drier	

Notes:

POR65131

To suit Porsche 911 996 Carrera
6 cyl 3.4 & 3.6L 1/1998 - 1/2006



Core Height	300mm	Core Width	478mm
Core Thickness	44mm	Inlet / Outlet	50 / 50
Oil Cooler	N/A		
Condenser		Receiver Drier	

Notes:

POR16651

To suit Porsche 911 996 Carrera
6 cyl 3.4 & 3.6L 1/1998 - 1/2006



Core Height	570mm	Core Width	129mm
Core Thickness	34mm	Inlet / Outlet	23 / 23
Oil Cooler	N/A		
Condenser		Receiver Drier	

Notes:

POR65141

To suit Porsche 911 996 GT2 Carrera
6 cyl 3.4 & 3.6L 1/1998 - 1/2006



Core Height	300mm	Core Width	478mm
Core Thickness	44mm	Inlet / Outlet	50 / 50
Oil Cooler	N/A		
Condenser		Receiver Drier	

Notes:

POR14291

To suit Porsche 911 996 GT3 Carrera
6 cyl 3.4 & 3.6L 1/1998 - 12/2008

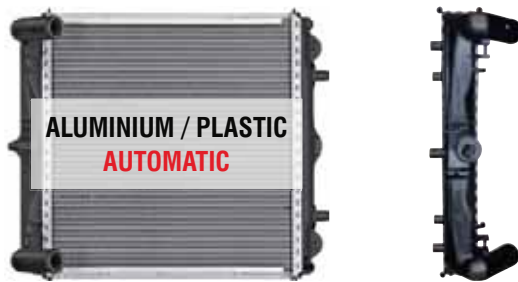

Core Height	335mm	Core Width	340mm
Core Thickness	52mm 1 Row	Inlet / Outlet	34 / 34
Oil Cooler	N/A		
Condenser		Receiver Drier	RDX576

Notes:

POR13791

To suit Porsche 911 996 GT3 Carrera
6 cyl 3.6L 1/1999 - 12/2008



Core Height	360mm	Core Width	336mm
Core Thickness	34mm	Inlet / Outlet	31 / 31
Oil Cooler	N/A		
Condenser		Receiver Drier	

Notes:

POR65111

To suit Porsche 911/996 Centre Module
6 cyl 3.4 & 3.6L 1997 - 2005



Core Height	608mm	Core Width	168mm
Core Thickness	44mm	Inlet / Outlet	42 / 42
Oil Cooler	N/A		
Condenser		Receiver Drier	

Notes:

POR29531

To suit Porsche 911/997 Centre Module
6 cyl 3.6 & 3.8L 2006 >



Core Height	608mm	Core Width	118mm
Core Thickness	42mm	Inlet / Outlet	40 / 40
Oil Cooler	N/A		
Condenser		Receiver Drier	

Notes:

POR33671

To suit Porsche 911/997 Right Module
6 cyl 3.6 & 3.8L 2006>



ALUMINIUM /
PLASTIC
AUTOMATIC

Core Height	340mm	Core Width	366mm
Core Thickness	42mm	Inlet / Outlet	35 / 38
Oil Cooler	N/A		
Condenser		Receiver Drier	

Notes:

POR30581

To suit Porsche 991/997 Left Module
6 cyl 3.6 & 3.8L 2006>



ALUMINIUM /
PLASTIC
AUTOMATIC

Core Height	340mm	Core Width	366mm
Core Thickness	42mm	Inlet / Outlet	35 / 38
Oil Cooler	N/A		
Condenser		Receiver Drier	

Notes:

AUD19001

To suit Porsche Cayenne
V6 3.6L & V8 4.5 & 4.8L Petrol inc Turbo
12/2006 >



ALUMINIUM / PLASTIC
AUTOMATIC & MANUAL

Core Height	710mm	Core Width	550mm
Core Thickness	40mm 1 Row	Inlet / Outlet	38 / 38
Oil Cooler	N/A		
Condenser	CNX910	Receiver Drier	

Notes:

P3CM

To suit Proton Gen 2 CM
4 cyl 1.6L 10/2004 >



ALUMINIUM / PLASTIC
MANUAL

Core Height	400mm	Core Width	690mm
Core Thickness	16mm 1 Row	Inlet / Outlet	36 / 36
Oil Cooler	N/A		
Condenser		Receiver Drier	RDX922

Notes:

PRO1728

To suit Proton Gen 2 CM
4 cyl 1.6L 10/2004 - 2006



ALUMINIUM / PLASTIC
MANUAL

Core Height	400mm	Core Width	690mm
Core Thickness	16mm 1 Row	Inlet / Outlet	36 / 36
Oil Cooler	N/A		
Condenser		Receiver Drier	

Notes:

P3CA

To suit Proton Gen 2 CM
4 cyl 1.6L 10/2004 >



ALUMINIUM / PLASTIC
AUTOMATIC

Core Height	400mm	Core Width	690mm
Core Thickness	27mm 1 Row	Inlet / Outlet	36 / 36
Oil Cooler	300mm		
Condenser		Receiver Drier	

Notes:

PRO1729

To suit Proton Gen 2 CM
4 cyl 1.6L 10/2004 - 2006



Core Height	400mm	Core Width	690mm
Core Thickness	16mm 1 Row	Inlet / Outlet	36 / 36
Oil Cooler	300mm		
Condenser		Receiver Drier	

Notes:

PRO51010

To suit Proton Jumbuck
4 cyl 1.5L 5/1995 >



Core Height	376mm	Core Width	412mm
Core Thickness	16mm 1 Row	Inlet / Outlet	35 / 35
Oil Cooler	N/A		
Condenser		Receiver Drier	

Notes:

MIT41013

To suit Proton Persona
4 cyl 1.5L 11/1996 - 5/2000



Core Height	376mm	Core Width	660mm
Core Thickness	32mm 2 Row	Inlet / Outlet	36 / 36
Oil Cooler	350mm		
Condenser	CNX085	Receiver Drier	RDX603

Notes:

MIT41014

To suit Proton Persona
4 cyl 1.5L 11/1996 - 5/2000



Core Height	376mm	Core Width	660mm
Core Thickness	32mm 2 Row	Inlet / Outlet	36 / 36
Oil Cooler	N/A		
Condenser	CNX085	Receiver Drier	RDX603

Notes:

MIT41013

To suit Proton Satria
4 cyl 1.5 & 1.6L 2/1997 - 2/2001



Core Height	376mm	Core Width	660mm
Core Thickness	32mm 2 Row	Inlet / Outlet	36 / 36
Oil Cooler	350mm		
Condenser	CNX085	Receiver Drier	RDX603

Notes:

MIT41014

To suit Proton Satria
4 cyl 1.5 & 1.6L 2/1997 - 2/2001



Core Height	376mm	Core Width	660mm
Core Thickness	32mm 2 Row	Inlet / Outlet	36 / 36
Oil Cooler	N/A		
Condenser	CNX085	Receiver Drier	RDX603

Notes:

PRO1727

To suit Proton Savvy Waja
4 cyl 1.1 & 1.6L 12/2001 - 10/2005



ALUMINIUM / PLASTIC
MANUAL

Core Height	480mm	Core Width	390mm
Core Thickness	16mm 1 Row	Inlet / Outlet	33 / 33
Oil Cooler	N/A		
Condenser		Receiver Drier	

Notes:

PRO1786

To suit Proton Waja CF
4 cyl 1.6L 12/2001 - 10/2005



ALUMINIUM / PLASTIC
MANUAL

Core Height	390mm	Core Width	690mm
Core Thickness	27mm 1 Row	Inlet / Outlet	36 / 36
Oil Cooler	N/A		
Condenser		Receiver Drier	

Notes:

PRO1787

To suit Proton Waja CF
4 cyl 1.6L 12/2001 - 10/2005



ALUMINIUM / PLASTIC
AUTOMATIC & MANUAL

Core Height	388mm	Core Width	690mm
Core Thickness	16mm 1 Row	Inlet / Outlet	36 / 36
Oil Cooler	300mm		
Condenser		Receiver Drier	

Notes:

MIT41014

To suit Proton Wira
4 cyl 1.5 & 1.6L 5/1995 - 11/1996



COPPER / PLASTIC
MANUAL

Core Height	376mm	Core Width	660mm
Core Thickness	32mm 2 Row	Inlet / Outlet	36 / 36
Oil Cooler	N/A		
Condenser	CNX085	Receiver Drier	RDX603

Notes:

MIT41013

To suit Proton Wira
4 cyl 1.5 & 1.6L 5/1995 - 11/1996



COPPER / PLASTIC
AUTOMATIC

Core Height	376mm	Core Width	660mm
Core Thickness	32mm 2 Row	Inlet / Outlet	36 / 36
Oil Cooler	350mm		
Condenser	CNX085	Receiver Drier	RDX603

Notes:

PRO51010

To suit Proton Wira Aeroback
4 cyl 1.5 & 1.6L 5/1995 - 11/1996



COPPER / PLASTIC
MANUAL

Core Height	376mm	Core Width	412mm
Core Thickness	16mm 1 Row	Inlet / Outlet	35 / 35
Oil Cooler	N/A		
Condenser		Receiver Drier	RDX281

Notes:

REN19671

To suit Renault Clio
4 cyl 1.6 5/2001 - 7/2008



Core Height	480mm	Core Width	414mm
Core Thickness	28mm 1 Row	Inlet / Outlet	32 / 32
Oil Cooler	N/A		
Condenser	CNX901	Receiver Drier	

Notes:

REN17781

To suit Renault Clio
4 cyl 1.6 & 2.0L 5/2001 - 11/2006



Core Height	480mm	Core Width	390mm
Core Thickness	34mm 1 Row	Inlet / Outlet	32 / 32
Oil Cooler	N/A		
Condenser	CNX901	Receiver Drier	

Notes:

REN71791

To suit Renault Kangoo
4 cyl 1.6L Petrol & 1.5 Turbo Diesel
8/2004 >



Core Height	458mm	Core Width	448mm
Core Thickness	26mm 1 Row	Inlet / Outlet	32 / 32
Oil Cooler	N/A		
Condenser		Receiver Drier	

Notes:

REN16291

To suit Renault Laguna
V6 2.9L 3/2002 - 5/2007



Core Height	680mm	Core Width	398mm
Core Thickness	40mm 1 Row	Inlet / Outlet	32 / 32
Oil Cooler	N/A		
Condenser	CNX902	Receiver Drier	RDX500

Notes:

REN72031

To suit Renault Megane
4 cyl 2.0L Petrol & 1.9 Turbo Diesel
12/2003 >



Core Height	590mm	Core Width	456mm
Core Thickness	26mm 1 Row	Inlet / Outlet	32 / 32
Oil Cooler	N/A		
Condenser	CNX904	Receiver Drier	

Notes:

REN81131

To suit Renault Megane
4 cyl 1.6L 5/2001 - 8/2008



Core Height	590mm	Core Width	453mm
Core Thickness	18mm 1 Row	Inlet / Outlet	32 / 32
Oil Cooler	N/A		
Condenser	CNX905	Receiver Drier	

Notes:

REN19661

To suit Renault Megane X84

4 cyl 1.6 & 2.0L Petrol & 1.9 Turbo Diesel
5/2001 - 4/2010



ALUMINIUM / PLASTIC
MANUAL

Core Height	585mm	Core Width	415mm
Core Thickness	26mm 1 Row	Inlet / Outlet	32 / 32
Oil Cooler	N/A		
Condenser	CNX904	Receiver Drier	

Notes:

REN19661

To suit Renault Scenic

4 cyl 1.6 & 2.0L 5/2001 - 1/2007



ALUMINIUM / PLASTIC
MANUAL

Core Height	585mm	Core Width	415mm
Core Thickness	26mm 1 Row	Inlet / Outlet	32 / 32
Oil Cooler	N/A		
Condenser	CNX904	Receiver Drier	

Notes:

ROV72211

To suit Rover Rover 75

V6 2.5L 3/2001 - 7/2004



ALUMINIUM / PLASTIC
MANUAL

Core Height	648mm	Core Width	445mm
Core Thickness	34mm 2 Row	Inlet / Outlet	32 / 33
Oil Cooler	N/A		
Condenser		Receiver Drier	

Notes:

SAA72401

To suit Saab 9-3

4 cyl 2.2 Petrol & 2.3L Petrol inc Turbo
6/1998 - 3/2004



ALUMINIUM / PLASTIC
AUTOMATIC

Core Height	610mm	Core Width	374mm
Core Thickness	25mm 1 Row	Inlet / Outlet	34 / 34
Oil Cooler	255mm		
Condenser	CNX578	Receiver Drier	RDX346

Notes:

HOL71211

To suit Saab 9-3

4 cyl 2.0L Turbo Efi 1/1998 - 2/2005



ALUMINIUM / PLASTIC
AUTOMATIC

Core Height	650mm	Core Width	405mm
Core Thickness	29mm 1 Row	Inlet / Outlet	35 / 35
Oil Cooler	255mm		
Condenser	CNX234	Receiver Drier	RDX163

Notes:

SAA20781

To suit Saab 9000

4 cyl 2.0, 2.3L Petrol & V6 3.0L Petrol inc Turbo
1/1987 - 3/1999

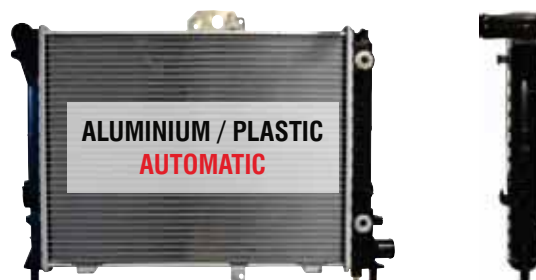

ALUMINIUM / PLASTIC
AUTOMATIC

Core Height	500mm	Core Width	390mm
Core Thickness	30mm 1 Row	Inlet / Outlet	34 / 34
Oil Cooler	280mm		
Condenser		Receiver Drier	RDX340

Notes:

SAA20661

To suit Saab 900

4 cyl 2.0, 2.3L & V6 2.5L 1/1984 - 6/1998



Core Height	500mm	Core Width	350mm
Core Thickness	42mm 1 Row	Inlet / Outlet	35 / 35
Oil Cooler	N/A		
Condenser	CNX570	Receiver Drier	RDX341

Notes:

SAA20531

To suit Saab 900

4 cyl 2.0L Petrol inc Turbo 1/1984 - 6/1998



Core Height	500mm	Core Width	345mm
Core Thickness	42mm 1 Row	Inlet / Outlet	35 / 35
Oil Cooler	280mm		
Condenser	CNX570	Receiver Drier	RDX344

Notes:

SAA05651

To suit Saab 900

4 cyl 2.0L Petrol inc Turbo 11/1981 - 6/1998



Core Height	595mm	Core Width	315mm
Core Thickness	32mm 2 Row	Inlet / Outlet	32 / 32
Oil Cooler	N/A		
Condenser	CNX570	Receiver Drier	RDX341 / RDX343

Notes:

SCA24611

To suit Scania 4 Series

8 cyl 9.0L Diesel 1996 - 2008



Core Height	860mm	Core Width	690mm
Core Thickness	42mm 1 Row	Inlet / Outlet	57 / 57
Oil Cooler	N/A		
Condenser		Receiver Drier	

Notes:

SCA21621

To suit Scania 4 Series

10.6, 11.0 & 14.0L 1997 >



Core Height	860mm	Core Width	930mm
Core Thickness	40mm 1 Row	Inlet / Outlet	57 / 57
Oil Cooler	N/A		
Condenser		Receiver Drier	

Notes:

VW14541

To suit Seat Cordoba

4 cyl 1.6 & 1.8L 1/1995 - 11/1999



Core Height	625mm	Core Width	375mm
Core Thickness	32mm 1 Row	Inlet / Outlet	32 / 32
Oil Cooler	N/A		
Condenser	CNX861	Receiver Drier	RDX908

Notes:

VW14541

To suit Seat Ibiza
4 cyl 1.4L 1/1995 - 9/1998



Core Height	625mm	Core Width	350mm
Core Thickness	32mm 1 Row	Inlet / Outlet	32 / 32
Oil Cooler	N/A		
Condenser	CNX861	Receiver Drier	RDX908

Notes:

VW65121

To suit Skoda Octavia
4 cyl 1.9L Turbo Diesel 10/2007 >



Core Height	650mm	Core Width	451mm
Core Thickness	34mm 2 Row	Inlet / Outlet	32 / 32
Oil Cooler	N/A		
Condenser	CNX870	Receiver Drier	RDX370

Notes:

VW81091

To suit Skoda Octavia
4 cyl 2.0L 10/2007 >



Core Height	647mm	Core Width	406mm
Core Thickness	26mm 1 Row	Inlet / Outlet	32 / 32
Oil Cooler	N/A		
Condenser	CNX870	Receiver Drier	RDX370

Notes:

VW74041

To suit Skoda Octavia
4 cyl 2.0L Turbo Diesel 10/2007 - 12/2009



Core Height	650mm	Core Width	455mm
Core Thickness	32mm 1 Row	Inlet / Outlet	32 / 32
Oil Cooler	N/A		
Condenser	CNX870	Receiver Drier	RDX370

Notes:

VW26701

To suit Skoda Octavia
4 cyl 1.9L Turbo Diesel 10/2007 >



Core Height	650mm	Core Width	410mm
Core Thickness	34mm 2 Row	Inlet / Outlet	32 / 32
Oil Cooler	N/A		
Condenser	CNX870	Receiver Drier	RDX370

Notes:

MER12551

To suit Smart For Two & Four
1.0 & 1.5L 3/2006 >



Core Height	380mm	Core Width	350mm
Core Thickness	14mm 1 Row	Inlet / Outlet	32 / 32
Oil Cooler	N/A		
Condenser		Receiver Drier	

Notes:

MER19751

To suit Smart Roadster R452
3 cyl 0.7L 11/2003 - 2/2008



Core Height	530mm	Core Width	286mm
Core Thickness	24mm 1 Row	Inlet / Outlet	34 / 34
Oil Cooler	N/A		
Condenser		Receiver Drier	

Notes:

SSM0001

To suit Ssangyong Musso
5 cyl 2.9L Turbo Diesel 8/1998 - 4/2003



Core Height	415mm	Core Width	680mm
Core Thickness	24mm 1 Row	Inlet / Outlet	34 / 34
Oil Cooler	350mm		
Condenser		Receiver Drier	RDX476

Notes: Return Pipe T/Tank. Sender Port B/Tank

SUB56000

To suit Subaru 1600
4 cyl 1.6L 5/1976 - 1/1980



Core Height	575mm	Core Width	330mm
Core Thickness	32mm 2 Row	Inlet / Outlet	32 / 32
Oil Cooler	135mm		
Condenser		Receiver Drier	

Notes:

SUB56001

To suit Subaru Brumby
4 cyl 1.8L 10/1980 - 1/1995



Core Height	645mm	Core Width	320mm
Core Thickness	16mm 1 Row	Inlet / Outlet	31 / 31
Oil Cooler	150mm		
Condenser		Receiver Drier	

Notes:

SUB56024

To suit Subaru Forester SG
4 cyl 2.5L 8/2003 - 12/2007



Core Height	345mm	Core Width	680mm
Core Thickness	24mm 1 Row	Inlet / Outlet	38 / 38
Oil Cooler	375mm		
Condenser		Receiver Drier	

Notes:

SUB56025

To suit Subaru Forester SG
4 cyl 2.5L 8/2003 - 12/2007



Core Height	345mm	Core Width	680mm
Core Thickness	24mm 1 Row	Inlet / Outlet	38 / 38
Oil Cooler	N/A		
Condenser		Receiver Drier	

Notes:

SUB56030

To suit Subaru Forester SG
4 cyl 2.5L inc Turbo 7/2002 - 3/2008



ALUMINIUM / PLASTIC
AUTOMATIC

Core Height	360mm	Core Width	680mm
Core Thickness	16mm 1 Row	Inlet / Outlet	40 / 40
Oil Cooler	375mm		
Condenser		Receiver Drier	

Notes: 8mm Bleeder Pipe

SUB1862

To suit Subaru Forester SG9
4 cyl 2.5L 7/2002 - 2005



ALUMINIUM / PLASTIC
MANUAL

Core Height	340mm	Core Width	680mm
Core Thickness	25mm 1 Row	Inlet / Outlet	39 / 39
Oil Cooler	N/A		
Condenser		Receiver Drier	

Notes:

SUB56032

To suit Subaru Forester SG
4 cyl 2.5L inc Turbo 7/2002 - 3/2008



ALUMINIUM / PLASTIC
AUTOMATIC

Core Height	360mm	Core Width	685mm
Core Thickness	16mm 1 Row	Inlet / Outlet	39 / 39
Oil Cooler	375mm		
Condenser		Receiver Drier	

Notes:

SUB1759

To suit Subaru Forester SF, SG
4 cyl 2.0 & 2.5L inc Turbo 8/1997 - 2005



ALUMINIUM / PLASTIC
MANUAL

Core Height	340mm	Core Width	686mm
Core Thickness	16mm 1 Row	Inlet / Outlet	39 / 39
Oil Cooler	N/A		
Condenser	CNX705	Receiver Drier	RDX609

Notes:

SUB1755

To suit Subaru Forester SF
4 cyl 2.0L inc Turbo 8/1997 - 7/2002



ALUMINIUM / PLASTIC
AUTOMATIC

Core Height	340mm	Core Width	687mm
Core Thickness	16mm 1 Row	Inlet / Outlet	39 / 39
Oil Cooler	375mm		
Condenser	CNX705	Receiver Drier	RDX609

Notes:

SUB1864

To suit Subaru Forester SF
4 cyl 2.0L inc Turbo 8/1997 - 2005



ALUMINIUM / PLASTIC
MANUAL

Core Height	340mm	Core Width	680mm
Core Thickness	25mm 1 Row	Inlet / Outlet	38 / 38
Oil Cooler	N/A		
Condenser	CNX705	Receiver Drier	RDX609

Notes: 8mm Bleeder Pipe

SUB1756

To suit Subaru Forester SF
4 cyl 2.0L inc Turbo 8/1997 - 7/2002



Core Height	340mm	Core Width	687mm
Core Thickness	16mm 1 Row	Inlet / Outlet	39 / 39
Oil Cooler	375mm		
Condenser	CNX705	Receiver Drier	RDX609

Notes: 8mm Bleeder Pipe

SUB1862

To suit Subaru Impreza WRX GD, GG
4 cyl 2.0 & 2.5L inc Turbo 6/2001 - 2/2008



Core Height	340mm	Core Width	680mm
Core Thickness	25mm 1 Row	Inlet / Outlet	39 / 39
Oil Cooler	N/A		
Condenser	CNX723	Receiver Drier	

Notes: 8mm Bleeder Pipe

SUB56024

To suit Subaru Impreza WRX GD, GG
4 cyl 2.0 & 2.5L inc Turbo 6/2001 - 12/2007



Core Height	345mm	Core Width	680mm
Core Thickness	24mm 1 Row	Inlet / Outlet	38 / 38
Oil Cooler	375mm		
Condenser	CNX723	Receiver Drier	

Notes:

SUB56025

To suit Subaru Impreza WRX GD, GG
4 cyl 2.0 & 2.5L inc Turbo 6/2001 - 12/2007



Core Height	345mm	Core Width	680mm
Core Thickness	24mm 1 Row	Inlet / Outlet	38 / 38
Oil Cooler	N/A		
Condenser	CNX723	Receiver Drier	

Notes:

SUB1865

To suit Subaru Impreza GD MY02
4 cyl 2.5L 10/2001 - 11/2002



Core Height	340mm	Core Width	685mm
Core Thickness	25mm 1 Row	Inlet / Outlet	38 / 38
Oil Cooler	380mm		
Condenser		Receiver Drier	

Notes:

SUB1759

To suit Subaru Impreza WRX GC, GG
4 cyl 2.0 & 2.5L inc Turbo 5/1996 - 9/2005



Core Height	340mm	Core Width	686mm
Core Thickness	16mm 1 Row	Inlet / Outlet	39 / 39
Oil Cooler	N/A		
Condenser	CNX705	Receiver Drier	RDX609

Notes:

SUB1864

To suit Subaru Impreza WRX GC - GR
4 cyl 2.0 & 2.5L inc Turbo 5/1996 - 9/2005



ALUMINIUM / PLASTIC
MANUAL

Core Height	340mm	Core Width	680mm
Core Thickness	25mm 1 Row	Inlet / Outlet	38 / 38
Oil Cooler	N/A		
Condenser	CNX701	Receiver Drier	RDX610

Notes:

SUB1754

To suit Subaru Impreza WRX GC - GG
4 cyl 2.0 & 2.5L inc Turbo 5/1996 - 2002



ALUMINIUM / PLASTIC
MANUAL

Core Height	340mm	Core Width	687mm
Core Thickness	16mm 1 Row	Inlet / Outlet	39 / 39
Oil Cooler	N/A		
Condenser	CNX701	Receiver Drier	RDX610

Notes: 8mm Bleeder Pipe

SUB1755

To suit Subaru Impreza WRX GC - GG
4 cyl 2.0 & 2.5L inc Turbo 11/1996 - 2002



ALUMINIUM / PLASTIC
AUTOMATIC

Core Height	340mm	Core Width	687mm
Core Thickness	16mm 1 Row	Inlet / Outlet	39 / 39
Oil Cooler	375mm		
Condenser	CNX705 (97-98)	Receiver Drier	RDX609 (97-98)

Notes:

SUB1756

To suit Subaru Impreza WRX GC - GG
4 cyl 2.0 & 2.5L inc Turbo 11/1996 - 2002



ALUMINIUM / PLASTIC
AUTOMATIC

Core Height	340mm	Core Width	687mm
Core Thickness	16mm 1 Row	Inlet / Outlet	39 / 39
Oil Cooler	375mm		
Condenser	CNX701	Receiver Drier	RDX610

Notes: 8mm Bleeder Pipe

SUB56021

To suit Subaru Impreza GC - GF
4 cyl 1.6 & 1.8L 4/1993 - 12/1998



ALUMINIUM / PLASTIC
MANUAL

Core Height	340mm	Core Width	685mm
Core Thickness	24mm 1 Row	Inlet / Outlet	40 / 40
Oil Cooler	N/A		
Condenser	CNX700 / CNX701	Receiver Drier	RDX220 / RDX610

Notes:

SUB56020

To suit Subaru Impreza GC - GF
4 cyl 1.6 & 1.8L 4/1993 - 12/1998



ALUMINIUM / PLASTIC
AUTOMATIC

Core Height	340mm	Core Width	685mm
Core Thickness	24mm 1 Row	Inlet / Outlet	40 / 40
Oil Cooler	200mm		
Condenser	CNX700 / CNX701	Receiver Drier	RDX220 / RDX610

Notes:

SUB1758

To suit Subaru Legacy
4 cyl 2.0L 1/1998 - 12/2003 (NZ)



ALUMINIUM / PLASTIC
MANUAL

Core Height	340mm	Core Width	687mm
Core Thickness	16mm 1 Row	Inlet / Outlet	39 / 39
Oil Cooler	N/A		
Condenser		Receiver Drier	

Notes:

SUB1631

To suit Subaru Legacy
4 cyl 2.5L 1/1994 - 12/1999 (NZ)



ALUMINIUM / PLASTIC
AUTOMATIC

Core Height	668mm	Core Width	395mm
Core Thickness	25mm 1 Row	Inlet / Outlet	40 / 40
Oil Cooler	200mm		
Condenser	CNX703	Receiver Drier	RDX220

Notes:

SUB56060

To suit Subaru Legacy
4 cyl 2.5L 1/1994 - 12/1999 (NZ)



ALUMINIUM / PLASTIC
AUTOMATIC

Core Height	670mm	Core Width	400mm
Core Thickness	16mm 1 Row	Inlet / Outlet	39 / 39
Oil Cooler	250mm		
Condenser		Receiver Drier	RDX610

Notes:

SUB56024

To suit Subaru Legacy
4 cyl 2.0L Turbo 1/1998 - 12/2003 (NZ)



ALUMINIUM / PLASTIC
AUTOMATIC

Core Height	345mm	Core Width	680mm
Core Thickness	24mm 1 Row	Inlet / Outlet	38 / 38
Oil Cooler	375mm		
Condenser		Receiver Drier	

Notes:

SUB56040

To suit Subaru Legacy
4 cyl 2.0 & 2.2L 1/1993 - 12/1998 (NZ)



ALUMINIUM / PLASTIC
AUTOMATIC

Core Height	670mm	Core Width	368mm
Core Thickness	16mm 1 Row	Inlet / Outlet	37 / 37
Oil Cooler	200mm		
Condenser		Receiver Drier	

Notes:

SUB56001

To suit Subaru Leone DI, GI
4 cyl 1.8L inc Turbo 1/1982 - 6/1995



COPPER / BRASS
AUTOMATIC

Core Height	645mm	Core Width	320mm
Core Thickness	16mm 1 Row	Inlet / Outlet	31 / 31
Oil Cooler	150mm		
Condenser		Receiver Drier	

Notes:

SUB56000

To suit Subaru Leone DI, GI
4 cyl 1.4, 1.6 & 2.0L 1/1975 - 6/1995



Core Height	575mm	Core Width	330mm
Core Thickness	32mm 2 Row	Inlet / Outlet	32 / 32
Oil Cooler	135mm		
Condenser		Receiver Drier	

Notes:

K9CM

To suit Subaru Liberty
6 cyl 3.0L 8/2004 - 10/2008



Core Height	350mm	Core Width	690mm
Core Thickness	16mm 1 Row	Inlet / Outlet	29 / 29 / 40
Oil Cooler	N/A		
Condenser		Receiver Drier	

Notes:

K9CA

To suit Subaru Liberty
6 cyl 3.0L 8/2004 - 10/2008



Core Height	350mm	Core Width	690mm
Core Thickness	16mm 1 Row	Inlet / Outlet	29 / 29 / 40
Oil Cooler	375mm		
Condenser		Receiver Drier	

Notes:

SUB1856

To suit Subaru Liberty EJ25, MY04
4 cyl 2.0 & 2.5L inc Turbo 1/2003 - 8/2007



Core Height	340mm	Core Width	685mm
Core Thickness	16mm 1 Row	Inlet / Outlet	40 / 40
Oil Cooler	380mm		
Condenser		Receiver Drier	

Notes:

SUB56024

To suit Subaru Liberty B4 MY04
4 cyl 2.0L inc Turbo 9/2003 - 8/2004



Core Height	345mm	Core Width	680mm
Core Thickness	24mm 1 Row	Inlet / Outlet	38 / 38
Oil Cooler	375mm		
Condenser	CNX723	Receiver Drier	

Notes:

SUB56025

To suit Subaru Liberty B4 MY04
4 cyl 2.0L inc Turbo 9/2003 - 8/2004



Core Height	345mm	Core Width	680mm
Core Thickness	24mm 1 Row	Inlet / Outlet	38 / 38
Oil Cooler	N/A		
Condenser	CNX723	Receiver Drier	

Notes:

SUB1758

To suit Subaru Liberty B4, H4
4 cyl 2.0 & 2.5L inc Turbo 10/1998 - 9/2003



ALUMINIUM / PLASTIC
MANUAL

Core Height	340mm	Core Width	687mm
Core Thickness	16mm 1 Row	Inlet / Outlet	39 / 39
Oil Cooler	N/A		
Condenser		Receiver Drier	RDX610

Notes:

SUB1864

To suit Subaru Liberty B4, H4
4 cyl 2.0 & 2.5L inc Turbo 10/1998 - 2005



ALUMINIUM / PLASTIC
MANUAL

Core Height	340mm	Core Width	680mm
Core Thickness	25mm 1 Row	Inlet / Outlet	38 / 38
Oil Cooler	N/A		
Condenser		Receiver Drier	RDX610

Notes:

SUB1757

To suit Subaru Liberty
4 cyl 2.0 & 2.5L 10/1998 - 9/2003



ALUMINIUM / PLASTIC
AUTOMATIC

Core Height	340mm	Core Width	687mm
Core Thickness	16mm 1 Row	Inlet / Outlet	39 / 39
Oil Cooler	375mm		
Condenser		Receiver Drier	RDX610

Notes: No Bleeder Pipe

SUB1754

To suit Subaru Liberty EJ25D
4 cyl 2.5L 9/1997 - 2/2000



ALUMINIUM / PLASTIC
MANUAL

Core Height	340mm	Core Width	687mm
Core Thickness	16mm 1 Row	Inlet / Outlet	39 / 39
Oil Cooler	N/A		
Condenser		Receiver Drier	RDX610

Notes:

SUB56060

To suit Subaru Liberty
4 cyl 2.5L 11/1996 - 2/2000



ALUMINIUM / PLASTIC
AUTOMATIC

Core Height	670mm	Core Width	400mm
Core Thickness	16mm 1 Row	Inlet / Outlet	39 / 39
Oil Cooler	250mm		
Condenser		Receiver Drier	RDX610

Notes:

SUB1070

To suit Subaru Liberty EJ20T, EJ22
4 cyl 2.0 & 2.2L inc Turbo 9/1991 - 6/1995



ALUMINIUM / PLASTIC
MANUAL

Core Height	669mm	Core Width	395mm
Core Thickness	25mm 1 Row	Inlet / Outlet	39 / 39
Oil Cooler	N/A		
Condenser	CNX702	Receiver Drier	RDX220

Notes: 8mm Bleeder Pipe

SUB56040

To suit Subaru Liberty
4 cyl 2.0 & 2.2L inc Turbo 10/1989 - 2/2000



Core Height	670mm	Core Width	368mm
Core Thickness	16mm 1 Row	Inlet / Outlet	37 / 37
Oil Cooler	200mm		
Condenser		Receiver Drier	RDX220

Notes:

SUB56055

To suit Subaru Liberty
4 cyl 2.0 & 2.2L inc Turbo 10/1989 - 2/2000



Core Height	670mm	Core Width	360mm
Core Thickness	32mm 2 Row	Inlet / Outlet	39 / 39
Oil Cooler	150mm		
Condenser		Receiver Drier	RDX220

Notes:

SUB1683

To suit Subaru Outback
2003 >



Core Height	340mm	Core Width	686mm
Core Thickness	16mm 1 Row	Inlet / Outlet	40 / 40
Oil Cooler	375mm		
Condenser		Receiver Drier	

Notes: 13mm Bleeder Pipe

SUB1856

To suit Subaru Outback BP9
4 cyl 2.5L 9/2003 - 8/2007



Core Height	340mm	Core Width	685mm
Core Thickness	16mm 1 Row	Inlet / Outlet	40 / 40
Oil Cooler	380mm		
Condenser	CNX7750	Receiver Drier	RDX0040

Notes:

K5CA

To suit Subaru Outback
6 cyl 3.0L 1/2000 - 10/2008



Core Height	350mm	Core Width	698mm
Core Thickness	28mm 1 Row	Inlet / Outlet	29 / 29 / 40
Oil Cooler	375mm		
Condenser	CNX4971	Receiver Drier	RDX0040

Notes:

K9CA

To suit Subaru Outback
6 cyl 3.0L 1/2000 - 10/2008



Core Height	350mm	Core Width	690mm
Core Thickness	16mm 1 Row	Inlet / Outlet	29 / 29 / 40
Oil Cooler	375mm		
Condenser		Receiver Drier	

Notes:

K9CM

To suit Subaru Outback
6 cyl 3.0L 1/2000 - 10/2008



ALUMINIUM / PLASTIC
MANUAL

Core Height	350mm	Core Width	690mm
Core Thickness	16mm 1 Row	Inlet / Outlet	29 / 29 / 40
Oil Cooler	N/A		
Condenser		Receiver Drier	

Notes:

SUB1758

To suit Subaru Outback BH9
4 cyl 2.5L 10/1998 - 9/2003



ALUMINIUM / PLASTIC
MANUAL

Core Height	340mm	Core Width	687mm
Core Thickness	16mm 1 Row	Inlet / Outlet	39 / 39
Oil Cooler	N/A		
Condenser	CNX4971	Receiver Drier	RDX0040

Notes:

SUB1757

To suit Subaru Outback BH9, BP9
4 cyl 2.5L 10/1998 - 9/2003



ALUMINIUM / PLASTIC
AUTOMATIC

Core Height	340mm	Core Width	687mm
Core Thickness	16mm 1 Row	Inlet / Outlet	39 / 39
Oil Cooler	375mm		
Condenser	CNX4971	Receiver Drier	RDX0040

Notes: No Bleeder Pipe

SUB56060

To suit Subaru Outback BG9
4 cyl 2.5L 9/1996 - 10/1998



ALUMINIUM / PLASTIC
AUTOMATIC

Core Height	670mm	Core Width	400mm
Core Thickness	16mm 1 Row	Inlet / Outlet	39 / 39
Oil Cooler	250mm		
Condenser	CNX821	Receiver Drier	RDX610

Notes:

SUB1482

To suit Subaru Tribeca
6 cyl 3.0L 11/2006 - 12/2007



ALUMINIUM / PLASTIC
AUTOMATIC

Core Height	675mm	Core Width	480mm
Core Thickness	27mm 1 Row	Inlet / Outlet	28 / 40
Oil Cooler	250mm		
Condenser	CNX724	Receiver Drier	

Notes:

H59CM

To suit Suzuki APV GD, G16
4 cyl 1.6L 8/2005 >



ALUMINIUM / PLASTIC
MANUAL

Core Height	475mm	Core Width	440mm
Core Thickness	16mm 1 Row	Inlet / Outlet	28 / 28
Oil Cooler	N/A		
Condenser	CNX8160	Receiver Drier	

Notes:

H18CA

To suit Suzuki Baleno
4 cyl 1.6 & 1.8L 4/1995 - 3/2002



Core Height	350mm	Core Width	526mm
Core Thickness	16mm 1 Row	Inlet / Outlet	29 / 29
Oil Cooler	300mm		
Condenser	CNX880	Receiver Drier	RDX604

Notes:

H18CM

To suit Suzuki Baleno
4 cyl 1.6 & 1.8L 4/1995 - 3/2002



Core Height	350mm	Core Width	526mm
Core Thickness	16mm 1 Row	Inlet / Outlet	29 / 29
Oil Cooler	N/A		
Condenser	CNX880	Receiver Drier	RDX604

Notes:

H19CA

To suit Suzuki Baleno
4 cyl 1.6 & 1.8L 4/1995 - 3/2002



Core Height	350mm	Core Width	600mm
Core Thickness	16mm 1 Row	Inlet / Outlet	34 / 34
Oil Cooler	300mm		
Condenser	CNX880	Receiver Drier	RDX604

Notes:

H19CM

To suit Suzuki Baleno
4 cyl 1.6 & 1.8L 4/1995 - 3/2002



Core Height	350mm	Core Width	605mm
Core Thickness	16mm 1 Row	Inlet / Outlet	34 / 34
Oil Cooler	N/A		
Condenser	CNX880	Receiver Drier	RDX604

Notes:

H20CA

To suit Suzuki Baleno
4 cyl 1.6 & 1.8L 4/1995 - 3/2002



Core Height	350mm	Core Width	600mm
Core Thickness	27mm 1 Row	Inlet / Outlet	28 / 28
Oil Cooler	300mm		
Condenser	CNX880	Receiver Drier	RDX604

Notes:

H20CM

To suit Suzuki Baleno
4 cyl 1.6 & 1.8L 4/1995 - 3/2002



Core Height	350mm	Core Width	603mm
Core Thickness	27mm 1 Row	Inlet / Outlet	29 / 29
Oil Cooler	N/A		
Condenser	CNX880	Receiver Drier	RDX604

Notes:

SUZ58002

To suit Suzuki Escudo
4 cyl 1.6L 1/1990 - 12/1997 (NZ)

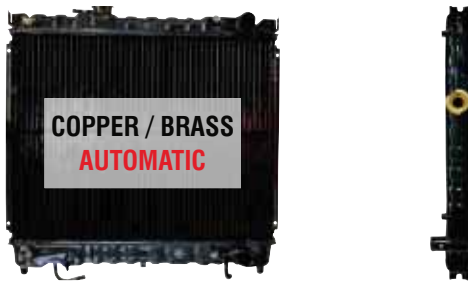

COPPER / BRASS
AUTOMATIC

Core Height	373mm	Core Width	498mm
Core Thickness	32mm 2 Row	Inlet / Outlet	29 / 29
Oil Cooler	325mm		
Condenser		Receiver Drier	RDX086

Notes:

SUZ58020

To suit Suzuki Escudo
4 cyl 1.6L 1/1990 - 12/1997 (NZ)



COPPER / BRASS
AUTOMATIC

Core Height	425mm	Core Width	490mm
Core Thickness	45mm 3 Row	Inlet / Outlet	29 / 29
Oil Cooler	325mm		
Condenser		Receiver Drier	RDX281

Notes:

H24CA

To suit Suzuki Escudo
4 cyl 1.6L 1/1988 - 10/1997 (NZ)



ALUMINIUM / PLASTIC
AUTOMATIC

Core Height	425mm	Core Width	480mm
Core Thickness	26mm 1 Row	Inlet / Outlet	28 / 28
Oil Cooler	325mm		
Condenser		Receiver Drier	

Notes:

SUZ1224

To suit Suzuki Grand Vitera JT, J20A
4 cyl 2.0L 6/2006 - 7/2008



ALUMINIUM / PLASTIC
AUTOMATIC

Core Height	450mm	Core Width	690mm
Core Thickness	16mm 1 Row	Inlet / Outlet	35 / 35
Oil Cooler	350mm		
Condenser	CNX890	Receiver Drier	

Notes:

H67CA

To suit Suzuki Grand Vitera H27A
V6 2.7L 9/2005 - 9/2008



ALUMINIUM / PLASTIC
AUTOMATIC

Core Height	450mm	Core Width	690mm
Core Thickness	16mm 1 Row	Inlet / Outlet	34 / 34
Oil Cooler	350mm		
Condenser	CNX890	Receiver Drier	RDX0050

Notes:

SUZ1223

To suit Suzuki Grand Vitera H27, XL7
V6 2.7L 8/2003 - 1/2006



ALUMINIUM / PLASTIC
AUTOMATIC

Core Height	450mm	Core Width	690mm
Core Thickness	16mm 1 Row	Inlet / Outlet	34 / 34
Oil Cooler	350mm		
Condenser	CNX890	Receiver Drier	RDX0050

Notes:

H23CA

To suit Suzuki Grand Vitara SQ, SV
4 cyl 2.0L & V6 2.5L 4/1998 - 9/2005



Core Height	425mm	Core Width	527mm
Core Thickness	27mm 1 Row	Inlet / Outlet	36 / 36
Oil Cooler	350mm		
Condenser	CNX890	Receiver Drier	RDX0040

Notes:

H23CM

To suit Suzuki Grand Vitara SQ, SV
4 cyl 2.0L & V6 2.5L 4/1998 - 9/2005



Core Height	425mm	Core Width	527mm
Core Thickness	27mm 1 Row	Inlet / Outlet	36 / 36
Oil Cooler	N/A		
Condenser	CNX890	Receiver Drier	RDX0040

Notes:

H36CM

To suit Suzuki Grand Vitara SV, SQ420
4 cyl 2.0L 4/1998 - 9/2005



Core Height	425mm	Core Width	525mm
Core Thickness	27mm 2 Row	Inlet / Outlet	34 / 34
Oil Cooler	N/A		
Condenser	CNX890	Receiver Drier	RDX0040

Notes:

H42CA

To suit Suzuki Grand Vitara XL7
V6 2.7L 7/2001 - 1/2006



Core Height	424mm	Core Width	602mm
Core Thickness	27mm 1 Row	Inlet / Outlet	35 / 35
Oil Cooler	350mm		
Condenser	CNX890	Receiver Drier	RDX0050

Notes:

H42CM

To suit Suzuki Grand Vitara XL7
V6 2.7L 7/2001 - 1/2006



Core Height	424mm	Core Width	602mm
Core Thickness	27mm 1 Row	Inlet / Outlet	34 / 34
Oil Cooler	N/A		
Condenser	CNX890	Receiver Drier	RDX0050

Notes:

H39CA

To suit Suzuki Ignis HV51, HX51
4 cyl 1.3L 10/2000 - 2/2006



Core Height	375mm	Core Width	353mm
Core Thickness	27mm 1 Row	Inlet / Outlet	28 / 28
Oil Cooler	250mm		
Condenser	CNX233	Receiver Drier	RDX115

Notes:

H39CM

To suit Suzuki Ignis HV51, HX51
4 cyl 1.3L 10/2000 - 2/2006



Core Height	375mm	Core Width	353mm
Core Thickness	27mm 1 Row	Inlet / Outlet	28 / 28
Oil Cooler	N/A		
Condenser	CNX233	Receiver Drier	RDX115

Notes:

H68CM

To suit Suzuki Jimny Sierra M13A
4 cyl 1.3L 2/2008 >



Core Height	374mm	Core Width	449mm
Core Thickness	27mm 1 Row	Inlet / Outlet	28 / 28
Oil Cooler	N/A		
Condenser		Receiver Drier	

Notes:

H35CA

To suit Suzuki Jimny SN413
4 cyl 1.3L 10/1998 - 9/2002



Core Height	375mm	Core Width	345mm
Core Thickness	26mm 1 Row	Inlet / Outlet	28 / 28
Oil Cooler	325mm		
Condenser		Receiver Drier	

Notes:

H35CM

To suit Suzuki Jimny SN413
4 cyl 1.3L 10/1998 - 9/2002



Core Height	374mm	Core Width	450mm
Core Thickness	28mm 1 Row	Inlet / Outlet	29 / 29
Oil Cooler	N/A		
Condenser		Receiver Drier	

Notes:

H45CA

To suit Suzuki Liana RA31, RA51
4 cyl 1.6 & 1.8L 11/2001 - 11/2007



Core Height	349mm	Core Width	717mm
Core Thickness	27mm 1 Row	Inlet / Outlet	34 / 34
Oil Cooler	300mm		
Condenser		Receiver Drier	

Notes:

H45CM

To suit Suzuki Liana RA31, RA51
4 cyl 1.6 & 1.8L 11/2001 - 11/2007



Core Height	349mm	Core Width	717mm
Core Thickness	27mm 1 Row	Inlet / Outlet	34 / 34
Oil Cooler	N/A		
Condenser		Receiver Drier	

Notes:

SUZ58003

To suit Suzuki Samurai
4 cyl 1.3L 1/1984 - 12/1989 (NZ)



COPPER / BRASS
MANUAL

Core Height	350mm	Core Width	388mm
Core Thickness	28mm 2 Row	Inlet / Outlet	28 / 28
Oil Cooler	N/A		
Condenser		Receiver Drier	RDX160

Notes:

H7CA

To suit Suzuki Sierra SJ70, SJ80
4 cyl 1.3L 1/1989 - 7/1999



COPPER / PLASTIC
AUTOMATIC

Core Height	350mm	Core Width	358mm
Core Thickness	32mm 2 Row	Inlet / Outlet	29 / 29
Oil Cooler	225mm		
Condenser		Receiver Drier	RDX160

Notes:

SUZ58110

To suit Suzuki Sierra SJ50, 80
4 cyl 1.3L 1/1988 - 7/1989



COPPER / PLASTIC
MANUAL

Core Height	325mm	Core Width	328mm
Core Thickness	32mm 2 Row	Inlet / Outlet	28 / 28
Oil Cooler	N/A		
Condenser		Receiver Drier	RDX160

Notes:

SUZ58003

To suit Suzuki Sierra SJ50, SJ51
4 cyl 1.3L 10/1983 - 12/1991



COPPER / BRASS
MANUAL

Core Height	350mm	Core Width	388mm
Core Thickness	28mm 2 Row	Inlet / Outlet	28 / 28
Oil Cooler	N/A		
Condenser		Receiver Drier	RDX160

Notes:

SUZ58001

To suit Suzuki Sierra F10A
4 cyl 1.0L 7/1981 - 12/1988



COPPER / BRASS
MANUAL

Core Height	300mm	Core Width	380mm
Core Thickness	32mm 2 Row	Inlet / Outlet	29 / 29
Oil Cooler	N/A		
Condenser		Receiver Drier	RDX086

Notes:

SUZ58035

To suit Suzuki Swift EZ M15A
4 cyl 1.5 & 1.6L 2/2005 >



ALUMINIUM / PLASTIC
AUTOMATIC

Core Height	375mm	Core Width	555mm
Core Thickness	24mm 1 Row	Inlet / Outlet	34 / 34
Oil Cooler	300mm		
Condenser	CNX0230	Receiver Drier	RDX0070

Notes: 8.5mm Tube Pitch

SUZ58037

To suit Suzuki Swift EZ M15A
4 cyl 1.5 & 1.6L 2/2005 >



ALUMINIUM / PLASTIC
MANUAL

Core Height	375mm	Core Width	555mm
Core Thickness	24mm 1 Row	Inlet / Outlet	35 / 35
Oil Cooler	N/A		
Condenser	CNX0230	Receiver Drier	RDX0070

Notes: 8.5mm Tube Pitch

SUZ58110

To suit Suzuki Swift SA, SF Cino
4 cyl 1.3L 1/1985 - 6/2000



COPPER / PLASTIC
MANUAL

Core Height	325mm	Core Width	328mm
Core Thickness	32mm 2 Row	Inlet / Outlet	28 / 28
Oil Cooler	N/A		
Condenser		Receiver Drier	RDX160

Notes:

H7CA

To suit Suzuki Swift SF
4 cyl 1.6L 10/1989 - 4/1996



COPPER / PLASTIC
AUTOMATIC

Core Height	350mm	Core Width	358mm
Core Thickness	32mm 2 Row	Inlet / Outlet	29 / 29
Oil Cooler	225mm		
Condenser		Receiver Drier	RDX160

Notes:

H63CA

To suit Suzuki SX4 GY, J20A
4 cyl 2.0L 2/2007 >



ALUMINIUM / PLASTIC
AUTOMATIC

Core Height	375mm	Core Width	710mm
Core Thickness	26mm 1 Row	Inlet / Outlet	34 / 34
Oil Cooler	300mm		
Condenser	CNX845	Receiver Drier	

Notes:

H62CM

To suit Suzuki SX4 GY
4 cyl 2.0L 8/2007 >



ALUMINIUM / PLASTIC
MANUAL

Core Height	375mm	Core Width	710mm
Core Thickness	16mm 1 Row	Inlet / Outlet	34 / 34
Oil Cooler	N/A		
Condenser	CNX845	Receiver Drier	

Notes:

SUZ1227

To suit Suzuki SX4 GY, J20A
4 cyl 2.0L 2/2007 >



ALUMINIUM / PLASTIC
AUTOMATIC

Core Height	375mm	Core Width	710mm
Core Thickness	27mm 1 Row	Inlet / Outlet	35 / 35
Oil Cooler	300mm		
Condenser	CNX845	Receiver Drier	

Notes:

H24CA

To suit Suzuki Vitara SV, SQ - 420, 620
4 cyl 2.0L & V6 2.0L 5/1997 - 5/1999



Core Height	425mm	Core Width	480mm
Core Thickness	26mm 1 Row	Inlet / Outlet	28 / 28
Oil Cooler	325mm		
Condenser		Receiver Drier	

Notes:

H24CM

To suit Suzuki Vitara SV, SQ - 420, 620
4 cyl 2.0L & V6 2.0L 3/1995 - 5/1999



Core Height	424mm	Core Width	488mm
Core Thickness	28mm 1 Row	Inlet / Outlet	29 / 29
Oil Cooler	N/A		
Condenser		Receiver Drier	RDX281

Notes:

H36CM

To suit Suzuki Vitara SV, SQ420
4 cyl 2.0L 5/1997 - 5/1999



Core Height	425mm	Core Width	525mm
Core Thickness	27mm 2 Row	Inlet / Outlet	34 / 34
Oil Cooler	N/A		
Condenser		Receiver Drier	

Notes:

H32CA

To suit Suzuki Vitara SE416, SZ416
4 cyl 1.6L 1/1995 - 5/1999



Core Height	375mm	Core Width	490mm
Core Thickness	26mm 1 Row	Inlet / Outlet	28 / 28
Oil Cooler	325mm		
Condenser	CNX2810	Receiver Drier	RDX086

Notes:

H32CM

To suit Suzuki Vitara SE416, SZ416
4 cyl 1.6L 1/1995 - 5/1999



Core Height	375mm	Core Width	488mm
Core Thickness	28mm 1 Row	Inlet / Outlet	29 / 29
Oil Cooler	N/A		
Condenser		Receiver Drier	RDX281

Notes:

H23CA

To suit Suzuki Vitara SV620
V6 2.0L 3/1995 - 4/1999



Core Height	425mm	Core Width	527mm
Core Thickness	27mm 1 Row	Inlet / Outlet	36 / 36
Oil Cooler	350mm		
Condenser		Receiver Drier	RDX281

Notes:

H23CM

To suit Suzuki Vitara SV620
V6 2.0L 3/1995 - 4/1999



Core Height	425mm	Core Width	527mm
Core Thickness	27mm 1 Row	Inlet / Outlet	36 / 36
Oil Cooler	N/A		
Condenser		Receiver Drier	RDX281

Notes:

SUZ58020

To suit Suzuki Vitara SV620
V6 2.0L 3/1995 - 4/1999



Core Height	425mm	Core Width	490mm
Core Thickness	45mm 3 Row	Inlet / Outlet	29 / 29
Oil Cooler	325mm		
Condenser		Receiver Drier	RDX281

Notes:

H24CM

To suit Suzuki Vitara SZ416
4 cyl 1.6L 8/1991 - 5/1999



Core Height	424mm	Core Width	488mm
Core Thickness	28mm 1 Row	Inlet / Outlet	29 / 29
Oil Cooler	N/A		
Condenser		Receiver Drier	RDX281

Notes:

SUZ58002

To suit Suzuki Vitara SE416, SZ416
4 cyl 1.6L 8/1989 - 4/1998

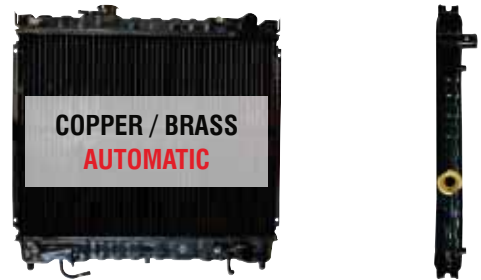

Core Height	373mm	Core Width	498mm
Core Thickness	32mm 2 Row	Inlet / Outlet	29 / 29
Oil Cooler	325mm		
Condenser		Receiver Drier	RDX086

Notes:

SUZ58004

To suit Suzuki Vitara SE SV416, SV620
4 cyl 1.6L & V6 2.0L 7/1988 - 5/1999



Core Height	425mm	Core Width	490mm
Core Thickness	32mm 2 Row	Inlet / Outlet	29 / 29
Oil Cooler	N/A		
Condenser		Receiver Drier	RDX281 / RDX086

Notes:

TOY61159

To suit Toyota 4 Runner VZN130
V6 3.0L 10/1990 - 7/1996



Core Height	450mm	Core Width	530mm
Core Thickness	45mm 3 Row	Inlet / Outlet	36 / 36
Oil Cooler	275mm		
Condenser	CNX1910	Receiver Drier	RDX282

Notes:

TOY61162

To suit Toyota 4 Runner RN130, YN130
4 cyl 2.4L 10/1989 - 7/1996

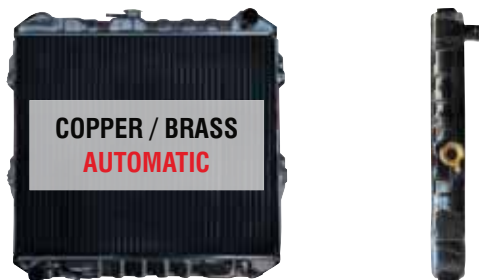

COPPER / BRASS
AUTOMATIC

Core Height	450mm	Core Width	530mm
Core Thickness	45mm 3 Row	Inlet / Outlet	36 / 36
Oil Cooler	375mm		
Condenser	CNX1290	Receiver Drier	RDX282

Notes:

TOY61209

To suit Toyota 4 Runner LN61, 130
4 cyl 2.8L Diesel 12/1985 - 7/1996



COPPER / BRASS
MANUAL

Core Height	475mm	Core Width	530mm
Core Thickness	45mm 3 Row	Inlet / Outlet	36 / 36
Oil Cooler	N/A		
Condenser		Receiver Drier	RDX281

Notes: Suits Power Steering Model

TOY61163

To suit Toyota 4 Runner LN60, 61
4 cyl 2.4L Diesel 8/1984 - 9/1989



COPPER / BRASS
AUTOMATIC

Core Height	450mm	Core Width	530mm
Core Thickness	45mm 3 Row	Inlet / Outlet	36 / 36
Oil Cooler	275mm		
Condenser		Receiver Drier	RDX086

Notes:

E80CA

To suit Toyota Altezza
6 cyl 2.0L 1/1998 - 12/2004 (NZ)



ALUMINIUM / PLASTIC
AUTOMATIC

Core Height	374mm	Core Width	716mm
Core Thickness	16mm 1 Row	Inlet / Outlet	35 / 35
Oil Cooler	375mm		
Condenser	CNX0240	Receiver Drier	RDX0050

Notes:

E114CA

To suit Toyota Aurion GSV40R, TRD
V6 3.5L inc Supercharged 10/2006 >



ALUMINIUM / PLASTIC
AUTOMATIC

Core Height	400mm	Core Width	770mm
Core Thickness	26mm 1 Row	Inlet / Outlet	34 / 34
Oil Cooler	380mm		
Condenser	CNX1170	Receiver Drier	RDX0070

Notes:

TOY60070

To suit Toyota Avalon MCX10R
V6 3.0L 7/2000 - 3/2006



ALUMINIUM / PLASTIC
AUTOMATIC

Core Height	424mm	Core Width	718mm
Core Thickness	24mm 1 Row	Inlet / Outlet	35 / 35
Oil Cooler	375mm		
Condenser	CNX1580	Receiver Drier	RDX281

Notes:

E70CA

To suit Toyota Avalon MCX10R
V6 3.0L 7/2000 - 3/2006



ALUMINIUM / PLASTIC
AUTOMATIC

Core Height	424mm	Core Width	718mm
Core Thickness	27mm 1 Row	Inlet / Outlet	35 / 35
Oil Cooler	375mm		
Condenser	CNX1580	Receiver Drier	RDX281

Notes:

E89CM

To suit Toyota Avensis ACM20R
4 cyl 2.0 & 2.4L 12/2001 >



ALUMINIUM / PLASTIC
AUTOMATIC

Core Height	423mm	Core Width	735mm
Core Thickness	27mm 1 Row	Inlet / Outlet	34 / 34
Oil Cooler	N/A		
Condenser	CNX3200	Receiver Drier	RDX0040

Notes: External Oil Cooler

E85CA

To suit Toyota Caldina ST215
4 cyl 2.0L 1/1992 - 12/2004 (NZ)



ALUMINIUM / PLASTIC
AUTOMATIC

Core Height	323mm	Core Width	660mm
Core Thickness	25mm 2 Row	Inlet / Outlet	33 / 33
Oil Cooler	350mm		
Condenser		Receiver Drier	

Notes:

E113CA

To suit Toyota Camry ACV40R
4 cyl 2.4L 7/2006 >



ALUMINIUM / PLASTIC
AUTOMATIC

Core Height	400mm	Core Width	730mm
Core Thickness	27mm 1 Row	Inlet / Outlet	34 / 34
Oil Cooler	375mm		
Condenser	CNX1170	Receiver Drier	RDX0070

Notes:

E113CM

To suit Toyota Camry ACV40R
4 cyl 2.4L 7/2006 >



ALUMINIUM / PLASTIC
MANUAL

Core Height	400mm	Core Width	730mm
Core Thickness	27mm 1 Row	Inlet / Outlet	34 / 34
Oil Cooler	N/A		
Condenser	CNX1170	Receiver Drier	RDX0070

Notes:

E90CM

To suit Toyota Camry ACV36R
4 cyl 2.4L 9/2002 - 7/2006



ALUMINIUM / PLASTIC
MANUAL

Core Height	400mm	Core Width	735mm
Core Thickness	26mm 1 Row	Inlet / Outlet	34 / 34
Oil Cooler	N/A		
Condenser	CNX8120	Receiver Drier	RDX0070

Notes:

E90CA

To suit Toyota Camry ACV36R
4 cyl 2.4L 9/2002 - 7/2006



ALUMINIUM / PLASTIC
AUTOMATIC

Core Height	400mm	Core Width	738mm
Core Thickness	27mm 1 Row	Inlet / Outlet	36 / 36
Oil Cooler	375mm		
Condenser	CNX8120	Receiver Drier	RDX0070

Notes:

TOY60272

To suit Toyota Camry ACV36R
4 cyl 2.4L 9/2002 - 7/2006



ALUMINIUM / PLASTIC
AUTOMATIC

Core Height	400mm	Core Width	738mm
Core Thickness	24mm 1 Row	Inlet / Outlet	36 / 36
Oil Cooler	375mm		
Condenser	CNX8120	Receiver Drier	RDX0070

Notes:

E91CA

To suit Toyota Camry MCV36R
V6 3.0L 9/2002 - 7/2006



ALUMINIUM / PLASTIC
AUTOMATIC

Core Height	400mm	Core Width	738mm
Core Thickness	27mm 1 Row	Inlet / Outlet	36 / 36
Oil Cooler	385mm		
Condenser	CNX8120	Receiver Drier	RDX0070

Notes:

E91CM

To suit Toyota Camry MCV36R
V6 3.0L 9/2002 - 7/2006



ALUMINIUM / PLASTIC
MANUAL

Core Height	400mm	Core Width	736mm
Core Thickness	27mm 1 Row	Inlet / Outlet	34 / 34
Oil Cooler	N/A		
Condenser	CNX8120	Receiver Drier	RDX0070

Notes:

E32CA

To suit Toyota Camry MCV20R
V6 3.0L 8/1997 - 9/2002



ALUMINIUM / PLASTIC
AUTOMATIC

Core Height	399mm	Core Width	737mm
Core Thickness	27mm 2 Row	Inlet / Outlet	35 / 35
Oil Cooler	375mm		
Condenser	CNX8110	Receiver Drier	RDX281

Notes:

TOY60270

To suit Toyota Camry MCV20R Vienta
V6 3.0L 8/1997 - 9/2002



ALUMINIUM / PLASTIC
AUTOMATIC

Core Height	400mm	Core Width	740mm
Core Thickness	24mm 1 Row	Inlet / Outlet	34 / 34
Oil Cooler	375mm		
Condenser	CNX8110	Receiver Drier	RDX281

Notes:

E31CA

To suit Toyota Camry SXV20R
4 cyl 2.2L 8/1997 - 9/2002



ALUMINIUM / PLASTIC
AUTOMATIC

Core Height	399mm	Core Width	737mm
Core Thickness	27mm 2 Row	Inlet / Outlet	33 / 33
Oil Cooler	375mm		
Condenser	CNX8110	Receiver Drier	RDX281

Notes:

TOY60260

To suit Toyota Camry SXV20R
4 cyl 2.2L 8/1997 - 9/2002



ALUMINIUM / PLASTIC
AUTOMATIC

Core Height	400mm	Core Width	738mm
Core Thickness	24mm 1 Row	Inlet / Outlet	31 / 31
Oil Cooler	375mm		
Condenser	CNX8110	Receiver Drier	RDX281

Notes:

15-TOY60260

To suit Toyota Camry SXV20R
4 cyl 2.2L 8/1997 - 9/2002



ALUMINIUM / PLASTIC
AUTOMATIC

Core Height	400mm	Core Width	738mm
Core Thickness	24mm 1 Row	Inlet / Outlet	31 / 31
Oil Cooler	375mm		
Condenser	CNX8110	Receiver Drier	RDX281

Notes:

TOY60230

To suit Toyota Camry SDV, SXV, XV10
4 cyl 2.2L 2/1993 - 5/1998



COPPER / PLASTIC
AUTOMATIC

Core Height	425mm	Core Width	715mm
Core Thickness	32mm 2 Row	Inlet / Outlet	31 / 31
Oil Cooler	375mm		
Condenser	CNX055	Receiver Drier	RDX281

Notes:

15-TOY60230

To suit Toyota Camry SDV, SXV, XV10
4 cyl 2.2L 2/1993 - 5/1998



ALUMINIUM / PLASTIC
AUTOMATIC

Core Height	425mm	Core Width	715mm
Core Thickness	32mm 2 Row	Inlet / Outlet	31 / 31
Oil Cooler	375mm		
Condenser	CNX055	Receiver Drier	RDX281

Notes:

TOY60232

To suit Toyota Camry VCV, VDV, VZV10R
V6 3.0L 2/1993 - 5/1998



COPPER / PLASTIC
AUTOMATIC

Core Height	425mm	Core Width	715mm
Core Thickness	32mm 2 Row	Inlet / Outlet	34 / 34
Oil Cooler	375mm		
Condenser	CNX055	Receiver Drier	RDX281

Notes:

TOY60226

To suit Toyota Camry SV20, 22
4 cyl 1.8 & 2.0L 5/1987 - 2/1993

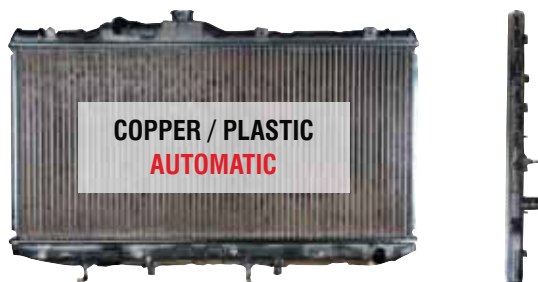

COPPER / PLASTIC
AUTOMATIC

Core Height	325mm	Core Width	665mm
Core Thickness	16mm 1 Row	Inlet / Outlet	31 / 31
Oil Cooler	275mm		
Condenser	CNX051	Receiver Drier	RDX161

Notes:

TOY60228

To suit Toyota Camry SV20, 22
4 cyl 1.8 & 2.0L 5/1987 - 2/1993



COPPER / PLASTIC
MANUAL

Core Height	325mm	Core Width	665mm
Core Thickness	16mm 1 Row	Inlet / Outlet	31 / 31
Oil Cooler	N/A		
Condenser	CNX051	Receiver Drier	RDX161

Notes:

TOY60063

To suit Toyota Celica ZTZ231
4 cyl 1.8L 11/1999 - 1/2006



ALUMINIUM / PLASTIC
AUTOMATIC

Core Height	650mm	Core Width	324mm
Core Thickness	16mm 1 Row	Inlet / Outlet	35 / 35
Oil Cooler	225mm		
Condenser	CNX1110	Receiver Drier	RDX0040

Notes:

E63CM

To suit Toyota Celica ZTZ231
4 cyl 1.8L 11/1999 - 1/2006



ALUMINIUM / PLASTIC
MANUAL

Core Height	650mm	Core Width	324mm
Core Thickness	16mm 1 Row	Inlet / Outlet	35 / 35
Oil Cooler	N/A		
Condenser	CNX1110	Receiver Drier	RDX0040

Notes:

E37CA

To suit Toyota Celica ST204
4 cyl 2.2L 2/1994 - 11/1999



ALUMINIUM / PLASTIC
AUTOMATIC

Core Height	350mm	Core Width	640mm
Core Thickness	27mm 2 Row	Inlet / Outlet	33 / 33
Oil Cooler	275mm		
Condenser		Receiver Drier	RDX281

Notes:

TOY1083

To suit Toyota Celica ST184
4 cyl 2.2L 9/1989 - 2/1995



ALUMINIUM / PLASTIC
AUTOMATIC

Core Height	325mm	Core Width	699mm
Core Thickness	27mm 2 Row	Inlet / Outlet	33 / 33
Oil Cooler	325mm		
Condenser		Receiver Drier	RDX282

Notes:

E36CM

To suit Toyota Celica ST184
4 cyl 2.2L 9/1989 - 2/1995



ALUMINIUM / PLASTIC
MANUAL

Core Height	325mm	Core Width	698mm
Core Thickness	27mm 1 Row	Inlet / Outlet	33 / 33
Oil Cooler	N/A		
Condenser		Receiver Drier	RDX282

Notes:

TOY60051

To suit Toyota Celica RA60 - 65, SA63
4 cyl 2.0 & 2.4L 11/1981 - 12/1985



COPPER / BRASS
AUTOMATIC

Core Height	375mm	Core Width	605mm
Core Thickness	32mm 2 Row	Inlet / Outlet	36 / 36
Oil Cooler	225mm		
Condenser	CNX062	Receiver Drier	RDX086

Notes:

TOY61310

To suit Toyota Coaster Bus
6 cyl 4.2L 1999 >



ALUMINIUM / PLASTIC
MANUAL

Core Height	490mm	Core Width	575mm
Core Thickness	52mm 2 Row	Inlet / Outlet	42 / 28 / 42
Oil Cooler	N/A		
Condenser		Receiver Drier	

Notes:

E118CA

To suit Toyota Corolla ZRE152R
4 cyl 1.8L 5/2007 >



ALUMINIUM / PLASTIC
AUTOMATIC

Core Height	600mm	Core Width	369mm
Core Thickness	15mm 1 Row	Inlet / Outlet	36 / 36
Oil Cooler	250mm		
Condenser	CNX1330	Receiver Drier	RDX0040

Notes:

E118CM

To suit Toyota Corolla ZRE152R
4 cyl 1.8L 5/2007 >



ALUMINIUM / PLASTIC
MANUAL

Core Height	600mm	Core Width	369mm
Core Thickness	15mm 1 Row	Inlet / Outlet	36 / 36
Oil Cooler	N/A		
Condenser	CNX1330	Receiver Drier	RDX0040

Notes:

TOY09370

To suit Toyota Corolla ZRE152, 153R
4 cyl 1.8 & 2.0L 5/2007 >



ALUMINIUM / PLASTIC
AUTOMATIC

Core Height	600mm	Core Width	373mm
Core Thickness	16mm 1 Row	Inlet / Outlet	36 / 36
Oil Cooler	250mm		
Condenser	CNX1330	Receiver Drier	RDX0040

Notes:

TOY09380

To suit Toyota Corolla ZRE152, 153R
4 cyl 1.8 & 2.0L 5/2007 >



Core Height	600mm	Core Width	373mm
Core Thickness	16mm 1 Row	Inlet / Outlet	36 / 36
Oil Cooler	N/A		
Condenser	CNX1330	Receiver Drier	RDX0040

Notes:

E87CA

To suit Toyota Corolla ZZE122R
4 cyl 1.8L 12/2001 - 5/2008



Core Height	600mm	Core Width	355mm
Core Thickness	16mm 1 Row	Inlet / Outlet	36 / 36
Oil Cooler	200mm		
Condenser	CNX3170	Receiver Drier	RDX0040

Notes:

E87CM

To suit Toyota Corolla ZZE122R
4 cyl 1.8L 12/2001 - 5/2008



Core Height	600mm	Core Width	355mm
Core Thickness	16mm 1 Row	Inlet / Outlet	36 / 36
Oil Cooler	N/A		
Condenser	CNX3170	Receiver Drier	RDX0040

Notes:

TOY60087

To suit Toyota Corolla ZZE122R
4 cyl 1.8L 12/2001 - 5/2008



Core Height	600mm	Core Width	355mm
Core Thickness	16mm 1 Row	Inlet / Outlet	36 / 36
Oil Cooler	200mm		
Condenser	CNX3170	Receiver Drier	RDX0040

Notes:

TOY60088

To suit Toyota Corolla ZZE122R
4 cyl 1.8L 12/2001 - 5/2008



Core Height	600mm	Core Width	355mm
Core Thickness	16mm 1 Row	Inlet / Outlet	36 / 36
Oil Cooler	N/A		
Condenser	CNX3170	Receiver Drier	RDX0040

Notes:

E29CA2

To suit Toyota Corolla Sprinter
4 cyl 1.8L 5/1994 - 5/1997



Core Height	350mm	Core Width	640mm
Core Thickness	16mm 1 Row	Inlet / Outlet	31 / 31
Oil Cooler	225mm		
Condenser	CNX4640	Receiver Drier	RDX604

Notes:

E28CA

To suit Toyota Corolla AE96
4 cyl 1.8L 10/1992 - 9/1994



ALUMINIUM / PLASTIC
AUTOMATIC

Core Height	325mm	Core Width	660mm
Core Thickness	27mm 1 Row	Inlet / Outlet	32 / 32
Oil Cooler	335mm		
Condenser	CNX056	Receiver Drier	RDX282

Notes:

E29CA2

To suit Toyota Corolla AE102
4 cyl 1.6 & 1.8L 9/1994 - 11/1999



ALUMINIUM / PLASTIC
AUTOMATIC

Core Height	350mm	Core Width	640mm
Core Thickness	16mm 1 Row	Inlet / Outlet	31 / 31
Oil Cooler	225mm		
Condenser	CNX4640	Receiver Drier	RDX604

Notes:

TOY60218

To suit Toyota Corolla AE101, 102 Sprinter
4 cyl 1.6 & 1.8L 5/1994 - 11/1999



COPPER / PLASTIC
AUTOMATIC

Core Height	350mm	Core Width	642mm
Core Thickness	16mm 1 Row	Inlet / Outlet	31 / 31
Oil Cooler	225mm		
Condenser	CNX4640	Receiver Drier	RDX604

Notes:

15-TOY60218

To suit Toyota Corolla AE101, 102 Sprinter
4 cyl 1.6 & 1.8L 5/1994 - 11/1999



ALUMINIUM / PLASTIC
AUTOMATIC

Core Height	350mm	Core Width	642mm
Core Thickness	16mm 1 Row	Inlet / Outlet	31 / 31
Oil Cooler	225mm		
Condenser	CNX4640	Receiver Drier	RDX604

Notes:

TOY60220

To suit Toyota Corolla AE101, 102 Sprinter
4 cyl 1.6 & 1.8L 5/1994 - 11/1999



COPPER / PLASTIC
MANUAL

Core Height	350mm	Core Width	638mm
Core Thickness	16mm 1 Row	Inlet / Outlet	32 / 32
Oil Cooler	N/A		
Condenser	CNX4640	Receiver Drier	RDX604

Notes:

TOY60214

To suit Toyota Corolla AE90, 95 Seca
4 cyl 1.6 & 1.8L 4/1988 - 10/1995



COPPER / PLASTIC
AUTOMATIC

Core Height	325mm	Core Width	665mm
Core Thickness	16mm 1 Row	Inlet / Outlet	31 / 31
Oil Cooler	225mm		
Condenser	CNX056 / CNX059	Receiver Drier	RDX284 / RDX282

Notes: CNX056 & RDX282 - R12
CNX059 & RDX284 - R134a

15-TOY60214

To suit Toyota Corolla AE90, 95 Seca
4 cyl 1.6 & 1.8L 4/1988 - 10/1995

revolution



Core Height	325mm	Core Width	665mm
Core Thickness	16mm 1 Row	Inlet / Outlet	31 / 31
Oil Cooler	225mm		
Condenser	CNX056 / CNX059	Receiver Drier	RDX284 / RDX282

Notes: CNX056 & RDX282 - R12, CNX059 & RDX284 - R134a

TOY60216

To suit Toyota Corolla AE90, 95 Seca
4 cyl 1.6 & 1.8L 4/1988 - 10/1995

OEX



Core Height	325mm	Core Width	665mm
Core Thickness	16mm 1 Row	Inlet / Outlet	31 / 31
Oil Cooler	N/A		
Condenser	CNX056 / CNX059	Receiver Drier	RDX284 / RDX282

Notes: CNX056 & RDX282 - R12, CNX059 & RDX284 - R134a

TOY60210

To suit Toyota Corolla AE80, AE82
4 cyl 1.3 & 1.6L 9/1985 - 5/1990

OEX



Core Height	325mm	Core Width	665mm
Core Thickness	16mm 1 Row	Inlet / Outlet	31 / 31
Oil Cooler	225mm		
Condenser		Receiver Drier	RDX086

Notes:

TOY60212

To suit Toyota Corolla AE80, AE82
4 cyl 1.3 & 1.6L 9/1985 - 5/1990

OEX



Core Height	325mm	Core Width	665mm
Core Thickness	16mm 1 Row	Inlet / Outlet	31 / 31
Oil Cooler	N/A		
Condenser		Receiver Drier	RDX086

Notes:

TOY60101

To suit Toyota Corolla AE80, 82
4 cyl 1.3 & 1.6L 9/1985 - 5/1990

OEX

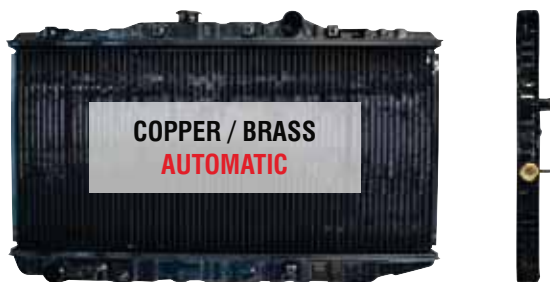

Core Height	325mm	Core Width	668mm
Core Thickness	16mm 1 Row	Inlet / Outlet	33 / 33
Oil Cooler	225mm		
Condenser		Receiver Drier	RDX086

Notes:

TOY60010

To suit Toyota Corolla AE71 KE35, KE70
4 cyl 1.2, 1.3 & 1.6L 11/1974 - 4/1986

OEX



Core Height	300mm	Core Width	445mm
Core Thickness	32mm 2 Row	Inlet / Outlet	35 / 35
Oil Cooler	225mm		
Condenser		Receiver Drier	RDX086

Notes:

E52CA

To suit Toyota Corolla AE111, 112
4 cyl 1.6 & 1.8L 1/1995 - 12/2001



ALUMINIUM / PLASTIC
AUTOMATIC

Core Height	350mm	Core Width	699mm
Core Thickness	16mm 1 Row	Inlet / Outlet	33 / 33
Oil Cooler	225mm		
Condenser	CNX4860	Receiver Drier	RDX604

Notes:

TOY60252

To suit Toyota Corolla AE111, 112
4 cyl 1.6 & 1.8L inc Turbo 1/1995 - 12/2001



ALUMINIUM / PLASTIC
MANUAL

Core Height	350mm	Core Width	699mm
Core Thickness	16mm 1 Row	Inlet / Outlet	33 / 33
Oil Cooler	225mm		
Condenser	CNX4860	Receiver Drier	RDX604

Notes:

TOY60040

To suit Toyota Corona RT104, RT118, RT132
4 cyl 2.0L 3/1974 - 1/1983

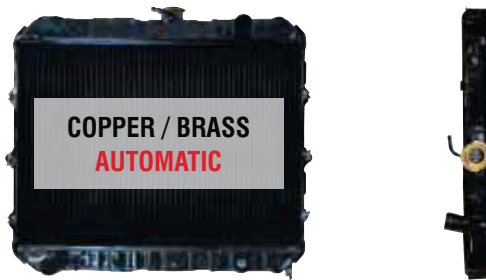

COPPER / BRASS
AUTOMATIC

Core Height	375mm	Core Width	528mm
Core Thickness	32mm 2 Row	Inlet / Outlet	35 / 35
Oil Cooler	225mm		
Condenser		Receiver Drier	

Notes:

TOY60020

To suit Toyota Corona RT133, 142, ST141
4 cyl 2.0 & 2.4L 1/1982 - 3/1988



COPPER / BRASS
AUTOMATIC

Core Height	375mm	Core Width	528mm
Core Thickness	32mm 2 Row	Inlet / Outlet	32 / 32
Oil Cooler	225mm		
Condenser	CNX062	Receiver Drier	RDX086

Notes:

TOY60030

To suit Toyota Corona RT133, XT130
4 cyl 1.9 & 2.0L 1/1979 - 11/1984

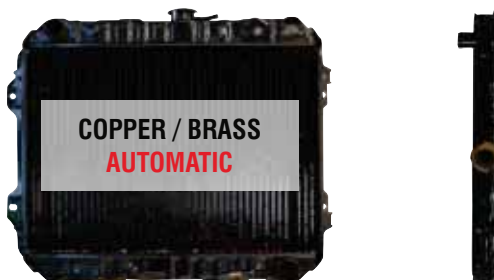

COPPER / BRASS
AUTOMATIC

Core Height	375mm	Core Width	528mm
Core Thickness	32mm 2 Row	Inlet / Outlet	32 / 38
Oil Cooler	225mm		
Condenser		Receiver Drier	RDX001

Notes:

E85CA

To suit Toyota Corona ST190
4 cyl 1.8L 1/1987 - 12/1993 (NZ)



ALUMINIUM / PLASTIC
AUTOMATIC

Core Height	323mm	Core Width	660mm
Core Thickness	25mm 2 Row	Inlet / Outlet	33 / 33
Oil Cooler	350mm		
Condenser		Receiver Drier	

Notes:

TOY1094

To suit Toyota Cressida MX83
6 cyl 3.0L 10/1988 - 8/1993



Core Height	378mm	Core Width	708mm
Core Thickness	32mm 2 Row	Inlet / Outlet	34 / 34
Oil Cooler	375mm		
Condenser		Receiver Drier	RDX282

Notes:

TOY1153

To suit Toyota Cressida MX73
6 cyl 2.8L 10/1984 - 5/1989



Core Height	378mm	Core Width	670mm
Core Thickness	32mm 2 Row	Inlet / Outlet	34 / 34
Oil Cooler	375mm		
Condenser		Receiver Drier	RDX086

Notes:

TOY2392

To suit Toyota Dyna 200, 400, B142, 212, 222R
4 cyl 4.1L Diesel 8/1995 - 5/2003



Core Height	475mm	Core Width	525mm
Core Thickness	46mm 3 Row	Inlet / Outlet	38 / 38
Oil Cooler	N/A		
Condenser		Receiver Drier	RDX284

Notes:

TOY60069

To suit Toyota Echo NCP10 - 12R
4 cyl 1.3 & 1.5L 9/1999 - 12/2005



Core Height	350mm	Core Width	488mm
Core Thickness	16mm 1 Row	Inlet / Outlet	31 / 31
Oil Cooler	N/A		
Condenser	CNX0640	Receiver Drier	RDX0040

Notes:

TOY60068

To suit Toyota Echo NCP10 - 12R
4 cyl 1.3 & 1.5L 9/1999 - 12/2005



Core Height	350mm	Core Width	488mm
Core Thickness	16mm 1 Row	Inlet / Outlet	31 / 31
Oil Cooler	225mm		
Condenser	CNX0640	Receiver Drier	RDX0040

Notes:

E68CA

To suit Toyota Echo NCP10 & 12R
4 cyl 1.3L 9/1999 - 12/2005



Core Height	350mm	Core Width	488mm
Core Thickness	16mm 1 Row	Inlet / Outlet	33 / 33
Oil Cooler	225mm		
Condenser	CNX0640	Receiver Drier	RDX0040

Notes:

TOY60172

To suit Toyota Estima

4 cyl 2.2 Turbo Diesel & 2.4L Petrol
1/1991 - 12/1999



COPPER / PLASTIC
AUTOMATIC

Core Height	424mm	Core Width	668mm
Core Thickness	32mm 2 Row	Inlet / Outlet	38 / 38
Oil Cooler	325mm		
Condenser	CNX1070	Receiver Drier	RDX287

Notes:

E83CA

To suit Toyota Forklift 7 Series

4 cyl 2.2L 1996 >



ALUMINIUM / PLASTIC
AUTOMATIC

Core Height	450mm	Core Width	450mm
Core Thickness	48mm 2 Row	Inlet / Outlet	34 / 34
Oil Cooler	250mm		
Condenser		Receiver Drier	

Notes: 1 Oil Cooler

E84CA

To suit Toyota Forklift 7 Series

4 cyl 2.2L 1996 >



ALUMINIUM / PLASTIC
AUTOMATIC

Core Height	525mm	Core Width	449mm
Core Thickness	48mm 2 Row	Inlet / Outlet	36 / 36
Oil Cooler	250mm		
Condenser		Receiver Drier	

Notes: 2 Oil Coolers

TOY1871

To suit Toyota Hiace KDH200, 223R

4 cyl 2.5L Turbo Diesel & 3.0L 3/2005 >



ALL ALUMINIUM
AUTOMATIC

Core Height	510mm	Core Width	660mm
Core Thickness	36mm 2 Row	Inlet / Outlet	31 / 38, 31 / 38
Oil Cooler	385mm		
Condenser	CNX9360	Receiver Drier	RDX0050

Notes:

TOY1870

To suit Toyota Hiace KDH200, 223R

4 cyl 2.5L Turbo Diesel & 3.0L 3/2005 >



ALL ALUMINIUM
MANUAL

Core Height	510mm	Core Width	660mm
Core Thickness	36mm 2 Row	Inlet / Outlet	31 / 38, 31 / 38
Oil Cooler	N/A		
Condenser	CNX9360	Receiver Drier	RDX0050

Notes:

TOY1869

To suit Toyota Hiace TRH201, 223R

4 cyl 2.7L 1/2005 >



ALL ALUMINIUM
AUTOMATIC

Core Height	510mm	Core Width	660mm
Core Thickness	36mm 2 Row	Inlet / Outlet	38 / 38
Oil Cooler	385mm		
Condenser	CNX9360	Receiver Drier	RDX0050

Notes:

TOY1868

To suit Toyota Hiace TRH201, 223R
4 cyl 2.7L 1/2005 >



ALL ALUMINIUM
MANUAL

Core Height	510mm	Core Width	660mm
Core Thickness	36mm 2 Row	Inlet / Outlet	38 / 38
Oil Cooler	N/A		
Condenser	CNX9360	Receiver Drier	RDX0050

Notes:

TOY200CM

To suit Toyota Hiace LH162, 172, 184R
4 cyl 3.0L Diesel 10/2000 - 3/2005



ALUMINIUM / PLASTIC
MANUAL

Core Height	500mm	Core Width	400mm
Core Thickness	36mm 2 Rows	Inlet / Outlet	34 / 34
Oil Cooler	N/A		
Condenser		Receiver Drier	

Notes: Cross Flow

TOY100CM

To suit Toyota Hiace RZH113, 125R
4 cyl 2.4L Petrol 9/1998 - 3/2005



ALUMINIUM / PLASTIC
MANUAL

Core Height	500mm	Core Width	405mm
Core Thickness	38mm 2 Rows	Inlet / Outlet	37 / 37
Oil Cooler	N/A		
Condenser	CNX4850 / CNX0290	Receiver Drier	RDX287

Notes: Cross Flow

TOY1989

To suit Toyota Hiace RZH103, 113R
4 cyl 2.4L Petrol 10/1989 - 1998



COPPER / BRASS
AUTOMATIC

Core Height	490mm	Core Width	465mm
Core Thickness	46mm 3 Row	Inlet / Outlet	34 / 34
Oil Cooler	275mm		
Condenser	CNX4850 / CNX0290	Receiver Drier	RDX287

Notes: Oil cooler on grill side

TOY1988

To suit Toyota Hiace RZH103, 113R
4 cyl 2.4L Petrol 10/1989 - 1998



COPPER / BRASS
AUTOMATIC

Core Height	490mm	Core Width	405mm
Core Thickness	30mm 2 Row	Inlet / Outlet	34 / 34
Oil Cooler	275mm		
Condenser	CNX4850 / CNX0290	Receiver Drier	RDX287

Notes: Oil cooler on grill side

TOY61010

To suit Toyota Hiace RZH103, 113, 125R
4 cyl 2.4L Petrol 9/1998 - 3/2005



COPPER / BRASS
MANUAL

Core Height	490mm	Core Width	410mm
Core Thickness	45mm 3 Row	Inlet / Outlet	36 / 36
Oil Cooler	N/A		
Condenser	CNX4850	Receiver Drier	RDX287

Notes:

E59CM

To suit Toyota Hiace RCH12, 22R
4 cyl 2.4L 10/1995 - 4/2004



ALUMINIUM / PLASTIC
MANUAL

Core Height	425mm	Core Width	680mm
Core Thickness	16mm 1 Row	Inlet / Outlet	33 / 33
Oil Cooler	N/A		
Condenser	CNX5550	Receiver Drier	RDX287

Notes:

TOY61020

To suit Toyota Hiace LH103, 113, 125R
4 cyl 2.8L Diesel 1/1989 - 10/2000



COPPER / BRASS
MANUAL

Core Height	490mm	Core Width	410mm
Core Thickness	45mm 3 Row	Inlet / Outlet	36 / 36
Oil Cooler	N/A		
Condenser	CNX1040 / CNX065	Receiver Drier	RDX287 / RDX281

Notes:

TOY61000

To suit Toyota Hiace RH11, 20, 32, 42
4 cyl 1.6 & 2.0L 1/1971 - 1/1986



COPPER / BRASS
MANUAL

Core Height	350mm	Core Width	490mm
Core Thickness	32mm 2 Row	Inlet / Outlet	36 / 36
Oil Cooler	N/A		
Condenser		Receiver Drier	

Notes:

E108CA

To suit Toyota Hilux GGN25R
V6 4.0L 1/2005 >



ALUMINIUM / PLASTIC
AUTOMATIC

Core Height	525mm	Core Width	650mm
Core Thickness	27mm 1 Row	Inlet / Outlet	34 / 34
Oil Cooler	375mm		
Condenser	CNX8820	Receiver Drier	RDX0070

Notes:

E107CM

To suit Toyota Hilux GGN25R
V6 4.0L 1/2005 >



ALUMINIUM / PLASTIC
MANUAL

Core Height	525mm	Core Width	650mm
Core Thickness	16mm 2 Row	Inlet / Outlet	34 / 34
Oil Cooler	N/A		
Condenser	CNX8820	Receiver Drier	RDX0070

Notes:

E105CA

To suit Toyota Hilux KUN16, 26R
4 cyl 3.0L Turbo Diesel 3/2005 >



ALUMINIUM / PLASTIC
AUTOMATIC

Core Height	525mm	Core Width	650mm
Core Thickness	27mm 1 Row	Inlet / Outlet	38 / 38
Oil Cooler	375mm		
Condenser	CNX8810	Receiver Drier	RDX0070

Notes: 8mm Bleeder Pipe D/S T/Tank

E104CM

To suit Toyota Hilux KUN16, 26R
4 cyl 3.0L Turbo Diesel 1/2005 >



ALUMINIUM / PLASTIC
MANUAL

Core Height	525mm	Core Width	650mm
Core Thickness	16mm 1 Row	Inlet / Outlet	38 / 38
Oil Cooler	N/A		
Condenser	CNX8810	Receiver Drier	RDX0070

Notes: 8mm Bleeder Pipe D/S T/Tank

TOY61192

To suit Toyota Hilux KUN16, 26R
4 cyl 3.0L Turbo Diesel 3/2005 >

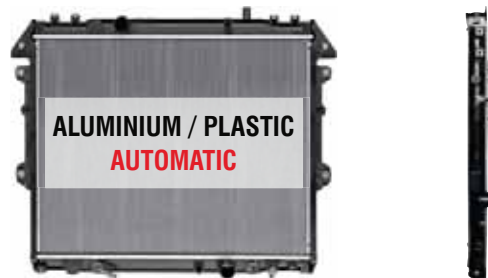

ALUMINIUM / PLASTIC
AUTOMATIC

Core Height	525mm	Core Width	650mm
Core Thickness	24mm 1 Row	Inlet / Outlet	38 / 38
Oil Cooler	375mm		
Condenser	CNX8810	Receiver Drier	RDX0070

Notes:

TOY61193

To suit Toyota Hilux KUN16, 26R
4 cyl 3.0L Turbo Diesel 3/2005 >



ALUMINIUM / PLASTIC
MANUAL

Core Height	525mm	Core Width	650mm
Core Thickness	16mm 1 Row	Inlet / Outlet	38 / 38
Oil Cooler	N/A		
Condenser	CNX8810	Receiver Drier	RDX0070

Notes:

TOY61194

To suit Toyota Hilux TGN16, 26R
4 cyl 2.7L 1/2005 >



ALUMINIUM / PLASTIC
MANUAL

Core Height	500mm	Core Width	650mm
Core Thickness	16mm 1 Row	Inlet / Outlet	34 / 34
Oil Cooler	N/A		
Condenser	CNX8820	Receiver Drier	RDX0070

Notes:

E106CM

To suit Toyota Hilux TGN16R
4 cyl 2.7L 1/2005 >



ALUMINIUM / PLASTIC
MANUAL

Core Height	500mm	Core Width	650mm
Core Thickness	16mm 1 Row	Inlet / Outlet	34 / 34
Oil Cooler	N/A		
Condenser	CNX8820	Receiver Drier	RDX0070

Notes:

E93CA

To suit Toyota Hilux VZN167, 172R
V6 3.4L 1/2002 - 3/2006



ALUMINIUM / PLASTIC
AUTOMATIC

Core Height	550mm	Core Width	525mm
Core Thickness	36mm 2 Row	Inlet / Outlet	34 / 34
Oil Cooler	375mm		
Condenser	CNX3820	Receiver Drier	RDX281

Notes:

E93CM

To suit Toyota Hilux VZN167, 172R
V6 3.4L 1/2002 - 3/2006



Core Height	550mm	Core Width	525mm
Core Thickness	36mm 2 Row	Inlet / Outlet	34 / 34
Oil Cooler	N/A		
Condenser	CNX3820	Receiver Drier	RDX281

Notes:

E76CM

To suit Toyota Hilux KZN165
4 cyl 3.0L Turbo Diesel 1/1998 - 3/2006



Core Height	550mm	Core Width	526mm
Core Thickness	36mm 2 Row	Inlet / Outlet	39 / 39
Oil Cooler	N/A		
Condenser	CNX3820	Receiver Drier	RDX281

Notes:

E82CM

To suit Toyota Hilux KZN165
4 cyl 3.0L Turbo Diesel 1/1998 - 3/2006



Core Height	550mm	Core Width	525mm
Core Thickness	36mm 2 Row	Inlet / Outlet	35 / 35
Oil Cooler	N/A		
Condenser	CNX3820	Receiver Drier	RDX281

Notes:

E57CA

To suit Toyota Hilux RZN149, 174R (RWD)
4 cyl 2.7L 10/1997 - 3/2006



Core Height	450mm	Core Width	528mm
Core Thickness	27mm 2 Row	Inlet / Outlet	35 / 35
Oil Cooler	375mm		
Condenser	CNX0130	Receiver Drier	RDX281

Notes:

E57CM

To suit Toyota Hilux RZN147, 149, 154,
169, 174
4 cyl 2.0 & 2.7L 1/1997 - 3/2006



Core Height	450mm	Core Width	528mm
Core Thickness	27mm 2 Row	Inlet / Outlet	35 / 35
Oil Cooler	N/A		
Condenser	CNX0130	Receiver Drier	RDX281

Notes:

TOY61178

To suit Toyota Hilux RZN149, 174R (RWD)
4 cyl 2.7L 10/1997 - 3/2006



Core Height	450mm	Core Width	520mm
Core Thickness	32mm 1 Row	Inlet / Outlet	34 / 34
Oil Cooler	375mm		
Condenser	CNX0130	Receiver Drier	RDX281

Notes:

TOY61180

To suit Toyota Hilux RZN147, 174R (RWD)
4 cyl 2.0 & 2.7L 1/1997 - 3/2006



Core Height	450mm	Core Width	520mm
Core Thickness	32mm 1 Row	Inlet / Outlet	34 / 34
Oil Cooler	N/A		
Condenser	CNX0130	Receiver Drier	RDX281

Notes:

TOY61182

To suit Toyota Hilux LN147 (RWD)
4 cyl 3.0L Diesel 10/1996 - 3/2006



Core Height	448mm	Core Width	518mm
Core Thickness	32mm 1 Row	Inlet / Outlet	33 / 33
Oil Cooler	N/A		
Condenser	CNX0130	Receiver Drier	RDX281

Notes:

E58CM

To suit Toyota Hilux LN147, 167, 172
4 cyl 3.0L 10/1996 - 3/2006



Core Height	475mm	Core Width	530mm
Core Thickness	36mm 2 Row	Inlet / Outlet	35 / 35
Oil Cooler	N/A		
Condenser		Receiver Drier	RDX281

Notes:

E73CM

To suit Toyota Hilux LN147
4 cyl 3.0L 10/1996 - 3/2006



Core Height	450mm	Core Width	526mm
Core Thickness	35mm 2 Row	Inlet / Outlet	35 / 35
Oil Cooler	N/A		
Condenser	CNX0130	Receiver Drier	RDX281

Notes:

TOY61188

To suit Toyota Hilux LN167, 172 (4WD)
4 cyl 3.0L Diesel 10/1996 - 3/2006



Core Height	473mm	Core Width	518mm
Core Thickness	32mm 1 Row	Inlet / Outlet	33 / 33
Oil Cooler	N/A		
Condenser		Receiver Drier	RDX281

Notes:

15-TOY61188

To suit Toyota Hilux LN167, 172 (4WD)
4 cyl 3.0L Diesel 10/1996 - 3/2006



Core Height	473mm	Core Width	518mm
Core Thickness	32mm 1 Row	Inlet / Outlet	33 / 33
Oil Cooler	N/A		
Condenser		Receiver Drier	RDX281

Notes:

TOY61209

To suit Toyota Hilux LN86, 111
4 cyl 2.8L Diesel 1/1992 - 1/1998



Core Height	475mm	Core Width	530mm
Core Thickness	45mm 3 Row	Inlet / Outlet	36 / 36
Oil Cooler	N/A		
Condenser		Receiver Drier	RDX281

Notes: Suits Power Steering Model

TOY1155

To suit Toyota Hilux LN86
4 cyl 2.8L Diesel 1/1988- 10/1997



Core Height	450mm	Core Width	530mm
Core Thickness	48mm 3 Row	Inlet / Outlet	35 / 35
Oil Cooler	N/A		
Condenser		Receiver Drier	RDX281

Notes:

TOY61161

To suit Toyota Hilux RN80
V6 3.0L 1989 - 1992



Core Height	475mm	Core Width	530mm
Core Thickness	45mm 3 Row	Inlet / Outlet	36 / 36
Oil Cooler	375mm		
Condenser		Receiver Drier	

Notes:

TOY61163

To suit Toyota Hilux LN56
4 cyl 2.4L Diesel 9/1984 - 9/1988



Core Height	450mm	Core Width	530mm
Core Thickness	45mm 3 Row	Inlet / Outlet	36 / 36
Oil Cooler	275mm		
Condenser		Receiver Drier	RDX086

Notes:

TOY61169

To suit Toyota Hilux RN85, 110 YN, 55, 85
4 cyl 2.4L 9/1984 - 11/1997



Core Height	425mm	Core Width	530mm
Core Thickness	32mm 2 Row	Inlet / Outlet	36 / 36
Oil Cooler	N/A		
Condenser		Receiver Drier	RDX281

Notes:

TOY61165

To suit Toyota Hilux RN85, 110 YN, 55, 85
4 cyl 2.4L 9/1984 - 11/1997



Core Height	400mm	Core Width	530mm
Core Thickness	32mm 2 Row	Inlet / Outlet	36 / 36
Oil Cooler	N/A		
Condenser		Receiver Drier	RDX281

Notes:

15-TOY61165

To suit Toyota Hilux RN85, 110 YN, 55, 85
4 cyl 2.4L 9/1984 - 11/1997

revolution



Core Height	400mm	Core Width	530mm
Core Thickness	32mm 2 Row	Inlet / Outlet	36 / 36
Oil Cooler	N/A		
Condenser		Receiver Drier	RDX281

Notes:

TOY61155

To suit Toyota Hilux LN55, 56, 65, 85R
4 cyl 2.2 & 2.4L Diesel 11/1983 - 10/1997

OEX



Core Height	450mm	Core Width	530mm
Core Thickness	45mm 3 Row	Inlet / Outlet	36 / 36
Oil Cooler	N/A		
Condenser		Receiver Drier	RDX086

Notes:

TOY61152

To suit Toyota Hilux LN40 46R
4 cyl 2.2L Diesel 1/1979 - 10/1986

OEX



Core Height	425mm	Core Width	530mm
Core Thickness	45mm 3 Row	Inlet / Outlet	36 / 36
Oil Cooler	N/A		
Condenser		Receiver Drier	RDX022

Notes:

TOY61158

To suit Toyota Hilux RN30 36, 40, 41, 46R, YN55
4 cyl 1.6 & 2.0L 1/1978 - 12/1987

OEX

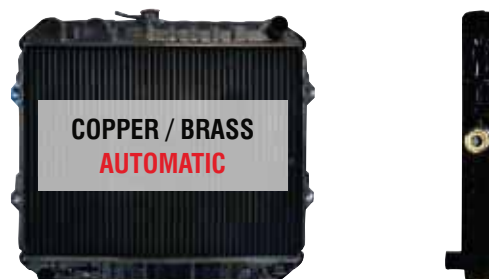

Core Height	400mm	Core Width	530mm
Core Thickness	45mm 3 Row	Inlet / Outlet	36 / 36
Oil Cooler	375mm		
Condenser		Receiver Drier	

Notes:

TOY61154

To suit Toyota Hilux RN30, 36, 40, 46R, YN55
4 cyl 1.6 & 2.0L 1/1978 - 12/1986

OEX



Core Height	375mm	Core Width	530mm
Core Thickness	32mm 2 Row	Inlet / Outlet	36 / 36
Oil Cooler	N/A		
Condenser		Receiver Drier	

Notes:

TOY61160

To suit Toyota Hilux RN85, 90, 105R
4 cyl 2.4L 1/1988 - 12/1997

OEX

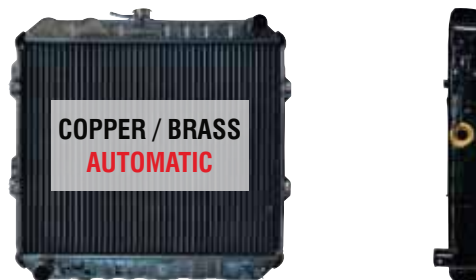

Core Height	425mm	Core Width	530mm
Core Thickness	45mm 3 Row	Inlet / Outlet	36 / 36
Oil Cooler	375mm		
Condenser		Receiver Drier	RDX281

Notes:

TOY61156

To suit Toyota Hilux RN85, 90R, YN57R
4 cyl 2.0 & 2.4L 1/1988 - 12/1997



COPPER / BRASS
AUTOMATIC

Core Height	400mm	Core Width	530mm
Core Thickness	32mm 2 Row	Inlet / Outlet	36 / 36
Oil Cooler	375mm		
Condenser		Receiver Drier	RDX281

Notes:

TOY61169

To suit Toyota Hilux Surf LN132
4 cyl 2.8L Diesel 1/1992 - 12/1996



COPPER / BRASS
MANUAL

Core Height	425mm	Core Width	530mm
Core Thickness	32mm 2 Row	Inlet / Outlet	36 / 36
Oil Cooler	N/A		
Condenser		Receiver Drier	RDX281

Notes:

TOY61165

To suit Toyota Hilux Surf LN132
4 cyl 2.8L Diesel 1/1992 - 12/1996



COPPER / BRASS
MANUAL

Core Height	400mm	Core Width	530mm
Core Thickness	32mm 2 Row	Inlet / Outlet	36 / 36
Oil Cooler	N/A		
Condenser		Receiver Drier	RDX281

Notes:

15-TOY61165

To suit Toyota Hilux Surf LN132
4 cyl 2.8L Diesel 1/1992 - 12/1996



ALUMINIUM / PLASTIC
MANUAL

Core Height	400mm	Core Width	530mm
Core Thickness	32mm 2 Row	Inlet / Outlet	36 / 36
Oil Cooler	N/A		
Condenser		Receiver Drier	RDX281

Notes:

TOY61160

To suit Toyota Hilux Surf LN132
4 cyl 2.8L Diesel 1/1992 - 12/1996



COPPER / BRASS
AUTOMATIC

Core Height	425mm	Core Width	530mm
Core Thickness	45mm 3 Row	Inlet / Outlet	36 / 36
Oil Cooler	375mm		
Condenser		Receiver Drier	RDX281

Notes:

TOY61156

To suit Toyota Hilux Surf LN132
4 cyl 2.8L Diesel 1/1992 - 12/1996



COPPER / BRASS
AUTOMATIC

Core Height	400mm	Core Width	530mm
Core Thickness	32mm 2 Row	Inlet / Outlet	36 / 36
Oil Cooler	375mm		
Condenser		Receiver Drier	RDX281

Notes:

TOY61157

To suit Toyota Hilux YN55, 67
4 cyl 1.6, 1.8, 2.0 & 2.2L 10/1978 - 2/1989



COPPER / BRASS
AUTOMATIC

Core Height	375mm	Core Width	530mm
Core Thickness	32mm 2 Rows	Inlet / Outlet	36 / 36
Oil Cooler	270mm		
Condenser		Receiver Drier	

Notes:

E119CA

To suit Toyota Kluger GSU40R, GSU45R
V6 3.5L 8/2007 >



ALUMINIUM / PLASTIC
AUTOMATIC

Core Height	475mm	Core Width	770mm
Core Thickness	27mm 2 Row	Inlet / Outlet	34 / 34
Oil Cooler	375mm		
Condenser	CNX2820	Receiver Drier	RDX0040

Notes:

E103CA

To suit Toyota Kluger MCU28R
V6 3.3L 10/2003 - 8/2007



ALUMINIUM / PLASTIC
AUTOMATIC

Core Height	450mm	Core Width	728mm
Core Thickness	27mm 1 Row	Inlet / Outlet	33 / 33
Oil Cooler	375mm		
Condenser	CNX2890	Receiver Drier	RDX0040

Notes:

E99CA

To suit Toyota Kluger MCU28R
V6 3.3L 10/2003 - 8/2007



ALUMINIUM / PLASTIC
AUTOMATIC

Core Height	450mm	Core Width	735mm
Core Thickness	16mm 1 Row	Inlet / Outlet	33 / 33
Oil Cooler	375mm		
Condenser	CNX2890	Receiver Drier	RDX0040

Notes:

TOY1138

To suit Toyota LandCruiser VDJ200R
V8 4.5L Turbo Diesel 11/2007 >



ALUMINIUM / PLASTIC
AUTOMATIC

Core Height	590mm	Core Width	715mm
Core Thickness	48mm 2 Row	Inlet / Outlet	38 / 42
Oil Cooler	390mm		
Condenser	CNX4401	Receiver Drier	RDX0040

Notes:

TOY1815

To suit Toyota LandCruiser VDJ 76-79R
V8 4.5L 3/2007 >



COPPER / BRASS
MANUAL

Core Height	560mm	Core Width	605mm
Core Thickness	66mm 4 Row	Inlet / Outlet	38 / 42
Oil Cooler	N/A		
Condenser	CNX4040	Receiver Drier	RDX0040

Notes:

TOY61260

To suit Toyota LandCruiser UZJ100R
V8 4.7L Petrol 3/1998 - 1/2008



ALUMINIUM / PLASTIC
AUTOMATIC

Core Height	510mm	Core Width	705mm
Core Thickness	52mm 2 Row	Inlet / Outlet	38 / 42
Oil Cooler	390mm		
Condenser	CNX0861	Receiver Drier	RDX0020

Notes:

TOY61217

To suit Toyota LandCruiser HDJ,
HZJ78, 79R
6 cyl 4.2L Diesel inc Turbo 1/1999 - 3/2007



COPPER / BRASS
MANUAL

Core Height	560mm	Core Width	525mm
Core Thickness	58mm 4 Row	Inlet / Outlet	38 / 41
Oil Cooler	N/A		
Condenser		Receiver Drier	RDX0040

Notes: 10mm Tube Pitch

TOY61240

To suit Toyota LandCruiser FZJ, HDJ,
HZJ105R
6 cyl 4.5L Petrol & 4.2L Diesel 3/1998 - 1/2008



ALUMINIUM / PLASTIC
AUTOMATIC

Core Height	425mm	Core Width	695mm
Core Thickness	52mm 1 Row	Inlet / Outlet	38 / 42
Oil Cooler	375mm		
Condenser	CNX4800	Receiver Drier	RDX0020

Notes:

TOY61242

To suit Toyota LandCruiser FZJ, HDJ,
HZJ105R
6 cyl 4.5L Petrol & 4.2L Diesel 3/1998 - 1/2008



ALUMINIUM / PLASTIC
MANUAL

Core Height	425mm	Core Width	705mm
Core Thickness	52mm 1 Row	Inlet / Outlet	38 / 42
Oil Cooler	N/A		
Condenser	CNX4800	Receiver Drier	RDX0020

Notes:

TOY61230

To suit Toyota LandCruiser FZJ, HDJ,
HZJ105R
6 cyl 4.5L Petrol & 4.2L Diesel 3/1998 - 1/2008



COPPER / PLASTIC
AUTOMATIC

Core Height	425mm	Core Width	700mm
Core Thickness	45mm 3 Row	Inlet / Outlet	38 / 42
Oil Cooler	390mm		
Condenser	CNX4800	Receiver Drier	RDX0020

Notes:

TOY61232

To suit Toyota LandCruiser FZJ, HDJ,
HZJ105R
6 cyl 4.5L Petrol & 4.2L Diesel 3/1998 - 1/2008



COPPER / PLASTIC
MANUAL

Core Height	425mm	Core Width	700mm
Core Thickness	45mm 3 Row	Inlet / Outlet	38 / 42
Oil Cooler	N/A		
Condenser	CNX4800	Receiver Drier	RDX0020

Notes:

TOY61220

To suit Toyota LandCruiser FZJ80, HDJ80
6 cyl 4.5L Petrol 5/1990 - 3/1999



COPPER / PLASTIC
MANUAL

Core Height	425mm	Core Width	716mm
Core Thickness	45mm 3 Row	Inlet / Outlet	38 / 42
Oil Cooler	N/A		
Condenser	CNX0830	Receiver Drier	RDX282

Notes:

TOY61216

To suit Toyota LandCruiser FZJ,
HDJ, HZJ80
6 cyl 4.5L Petrol & 4.2L Diesel 5/1990 - 3/1999



COPPER / BRASS
AUTOMATIC

Core Height	425mm	Core Width	730mm
Core Thickness	45mm 3 Row	Inlet / Outlet	40 / 40
Oil Cooler	390mm		
Condenser	CNX0830	Receiver Drier	RDX282 / RDX613

Notes: RDX282 - R134A, RDX613 - R12, Multi Fit

TOY08850

To suit Toyota LandCruiser FZJ80
6 cyl 4.5L 5/1990 - 12/1998



COPPER / PLASTIC
AUTOMATIC

Core Height	425mm	Core Width	715mm
Core Thickness	48mm 3 Row	Inlet / Outlet	38 / 42
Oil Cooler	390mm		
Condenser	CNX0830	Receiver Drier	RDX282 / RDX613

Notes: RDX282 - R134A, RDX613 - R12

TOY2217

To suit Toyota LandCruiser 80 Series
4.2L Diesel 1990 - 1995



ALUMINIUM / PLASTIC
MANUAL

Core Height	425mm	Core Width	730mm
Core Thickness	48mm	Inlet / Outlet	38 / 42
Oil Cooler	N/A		
Condenser	CNX0830	Receiver Drier	RDX282

Notes: Receiver options RDX282 (04/93>, R134a) RDX613 (90-93, R12)

TOY61211

To suit Toyota LandCruiser FZJ75, HZJ75
6 cyl 4.5L Petrol & 4.2L Diesel 1/1985 - 10/1999



COPPER / BRASS
MANUAL

Core Height	500mm	Core Width	520mm
Core Thickness	65mm 4 Row	Inlet / Outlet	39 / 39
Oil Cooler	N/A		
Condenser		Receiver Drier	RDX282

Notes:

TOY61215

To suit Toyota LandCruiser FZJ75, HZJ73,
75, PZJ73
6 cyl 4.5L Petrol & 3.5 & 4.2L Diesel 1/1985 - 12/1999



COPPER / BRASS
MANUAL

Core Height	500mm	Core Width	520mm
Core Thickness	65mm 4 Row	Inlet / Outlet	41 / 39
Oil Cooler	N/A		
Condenser		Receiver Drier	RDX282

Notes:

TOY61206

To suit Toyota LandCruiser FJ70, 73, 75
6 cyl 4.0L 1/1985 - 11/1992



COPPER / BRASS
MANUAL

Core Height	450mm	Core Width	530mm
Core Thickness	65mm 4 Row	Inlet / Outlet	39 / 39
Oil Cooler	N/A		
Condenser	CNX052	Receiver Drier	RDX086

Notes:

TOY61214

To suit Toyota LandCruiser FJ62, HJ61
6 cyl 4.0L inc Turbo 1/1985 - 1/1991



COPPER / BRASS
MANUAL

Core Height	398mm	Core Width	610mm
Core Thickness	65mm 4 Row	Inlet / Outlet	39 / 39
Oil Cooler	N/A		
Condenser	CNX068	Receiver Drier	RDX086

Notes:

TOY61208

To suit Toyota LandCruiser BJ70, 73,
HJ60, 75
4 & 6 cyl Diesel 1/1985 - 12/1991



COPPER / BRASS
MANUAL

Core Height	495mm	Core Width	530mm
Core Thickness	65mm 4 Row	Inlet / Outlet	39 / 39
Oil Cooler	N/A		
Condenser		Receiver Drier	RDX282

Notes:

TOY61210

To suit Toyota LandCruiser HJ60
6 cyl 4.0L Diesel inc Turbo 11/1980 - 4/1991



COPPER / BRASS
MANUAL

Core Height	398mm	Core Width	610mm
Core Thickness	65mm 4 Row	Inlet / Outlet	39 / 39
Oil Cooler	N/A		
Condenser	CNX067	Receiver Drier	RDX086

Notes:

TOY61205

To suit Toyota LandCruiser FJ60
6 cyl 4.2L 11/1980 - 4/1990



COPPER / BRASS
MANUAL

Core Height	380mm	Core Width	610mm
Core Thickness	65mm 4 Row	Inlet / Outlet	39 / 39
Oil Cooler	N/A		
Condenser		Receiver Drier	RDX086

Notes:

TOY61207

To suit Toyota LandCruiser HJ47
6 cyl 4.0L Diesel 10/1980 - 12/1984



COPPER / BRASS
MANUAL

Core Height	435mm	Core Width	530mm
Core Thickness	65mm 4 Row	Inlet / Outlet	39 / 39
Oil Cooler	N/A		
Condenser		Receiver Drier	RDX086

Notes:

TOY61200

To suit Toyota LandCruiser BJ42
4 cyl 3.4L Diesel 6/1980 - 12/1984



COPPER / BRASS
MANUAL

Core Height	435mm	Core Width	495mm
Core Thickness	65mm 4 Row	Inlet / Outlet	39 / 39
Oil Cooler	N/A		
Condenser		Receiver Drier	RDX022

Notes:

TOY61201

To suit Toyota LandCruiser FJ40
6 cyl 4.2L 1/1970 - 12/1984



COPPER / BRASS
MANUAL

Core Height	435mm	Core Width	495mm
Core Thickness	65mm 4 Row	Inlet / Outlet	39 / 39
Oil Cooler	N/A		
Condenser		Receiver Drier	RDX086

Notes:

TOY61203

To suit Toyota LandCruiser FJ40, 45
6 cyl 4.2L 1/1970 - 12/1984



COPPER / BRASS
MANUAL

Core Height	435mm	Core Width	530mm
Core Thickness	65mm 4 Row	Inlet / Outlet	39 / 39
Oil Cooler	N/A		
Condenser		Receiver Drier	RDX086

Notes:

TOY61202

To suit Toyota LandCruiser FJ55
6 cyl 3.9L 1/1966 - 11/1980



COPPER / BRASS
MANUAL

Core Height	400mm	Core Width	550mm
Core Thickness	65mm 4 Row	Inlet / Outlet	39 / 39
Oil Cooler	N/A		
Condenser		Receiver Drier	

Notes:

TOY61204

To suit Toyota LandCruiser FJ40, 45
6 cyl 3.9L 1/1965 - 12/1984



COPPER / BRASS
MANUAL

Core Height	435mm	Core Width	490mm
Core Thickness	45mm 3 Row	Inlet / Outlet	39 / 39
Oil Cooler	N/A		
Condenser		Receiver Drier	

Notes:

HOL24300

To suit Toyota Lexcen T5 V6
3.8L 6/1996 - 8/1997



ALUMINIUM / PLASTIC
AUTOMATIC

Core Height	548mm	Core Width	420mm
Core Thickness	24mm 1 Row	Inlet / Outlet	35 / 40
Oil Cooler	275mm		
Condenser	CNX028	Receiver Drier	RDX101

Notes: Screw on Oil Cooler Fittings

15-HOL24300

To suit Toyota Lexcen T5
V6 3.8L 6/1996 - 8/1997

revolution



Core Height	548mm	Core Width	420mm
Core Thickness	24mm 1 Row	Inlet / Outlet	35 / 40
Oil Cooler	275mm		
Condenser	CNX028	Receiver Drier	RDX101

Notes: Screw on Oil Cooler Fittings

HOL24200

To suit Toyota Lexcen VP - VR
V6 3.8L 11/1991 - 6/1996

OEX



Core Height	545mm	Core Width	420mm
Core Thickness	24mm 1 Row	Inlet / Outlet	35 / 39
Oil Cooler	275mm		
Condenser	CNX028	Receiver Drier	RDX101

Notes:

15-HOL24200

To suit Toyota Lexcen VP, VR
V6 3.8L 11/1991 - 6/1996

revolution

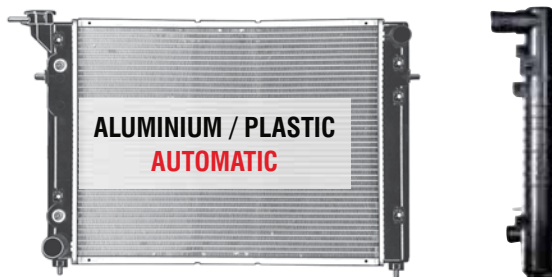

Core Height	545mm	Core Width	420mm
Core Thickness	24mm 1 Row	Inlet / Outlet	35 / 39
Oil Cooler	275mm		
Condenser	CNX028	Receiver Drier	RDX101

Notes:

HOL24100

To suit Toyota Lexcen VN
V6 3.8L 9/1989 - 11/1991

OEX



Core Height	545mm	Core Width	420mm
Core Thickness	24mm 1 Row	Inlet / Outlet	35 / 39
Oil Cooler	250mm		
Condenser	CNX027	Receiver Drier	RDX104

Notes:

TOY60172

To suit Toyota Lucida
4 cyl 2.4L 1/1992 - 12/1999 (NZ)

OEX



Core Height	424mm	Core Width	668mm
Core Thickness	32mm 2 Row	Inlet / Outlet	38 / 38
Oil Cooler	325mm		
Condenser	CNX1070	Receiver Drier	RDX287

Notes:

E94CM

To suit Toyota MR2 ZZW30R
4 cyl 1.8L 10/2000 - 3/2006

DENSO



Core Height	650mm	Core Width	325mm
Core Thickness	16mm 1 Row	Inlet / Outlet	34 / 34
Oil Cooler	N/A		
Condenser		Receiver Drier	RDX0050

Notes:

E45CM

To suit Toyota Paseo EL44
4 cyl 1.5L 6/1991 - 11/1995



ALUMINIUM / PLASTIC
MANUAL

Core Height	325mm	Core Width	661mm
Core Thickness	27mm 1 Row	Inlet / Outlet	29 / 29
Oil Cooler	N/A		
Condenser	CNX1620	Receiver Drier	RDX284

Notes:

E121CA

To suit Toyota Prado GRJ150R
6 cyl 4.0L 11/2009 >



ALUMINIUM / PLASTIC
AUTOMATIC

Core Height	574mm	Core Width	651mm
Core Thickness	27mm 1 Row	Inlet / Outlet	30 / 30
Oil Cooler	N/A		
Condenser	CNX6270	Receiver Drier	RDX0070

Notes:

TOY61272

To suit Toyota Prado GRJ120R
6 cyl 4.0L 2/2003 - 12/2009



ALUMINIUM / PLASTIC
AUTOMATIC

Core Height	649mm	Core Width	593mm
Core Thickness	24mm 1 Row	Inlet / Outlet	34 / 34
Oil Cooler	250mm		
Condenser	CNX9810	Receiver Drier	RDX0040

Notes:

E96CA

To suit Toyota Prado GRJ120R
6 cyl 4.0L 2/2003 - 12/2009



ALUMINIUM / PLASTIC
AUTOMATIC

Core Height	649mm	Core Width	593mm
Core Thickness	27mm 1 Row	Inlet / Outlet	34 / 34
Oil Cooler	250mm		
Condenser	CNX7710	Receiver Drier	RDX0040

Cross Flow

TOY09570

To suit Toyota Prado GRJ RZJ120R
V6 4.0L & 4 cyl 2.7L 2/2003 - 12/2009



ALUMINIUM / PLASTIC
AUTOMATIC

Core Height	649mm	Core Width	590mm
Core Thickness	26mm 1 Row	Inlet / Outlet	34 / 34
Oil Cooler	250mm		
Condenser	CNX7730	Receiver Drier	RDX0040

Notes:

TOY09581

To suit Toyota Prado GRJ, RZJ120R
V6 4.0L & 4 cyl 2.7L 2/2003 - 12/2009



ALUMINIUM / PLASTIC
MANUAL

Core Height	649mm	Core Width	590mm
Core Thickness	26mm 1 Row	Inlet / Outlet	34 / 34
Oil Cooler	N/A		
Condenser	CNX7730	Receiver Drier	RDX0040

Notes:

E95CA

To suit Toyota Prado RZJ120R
4 cyl 2.7L 2/2003 - 9/2004



ALUMINIUM / PLASTIC
AUTOMATIC

Core Height	650mm	Core Width	593mm
Core Thickness	16mm 1 Row	Inlet / Outlet	34 / 34
Oil Cooler	250mm		
Condenser	CNX7730	Receiver Drier	RDX0040

Notes:

E95CM

To suit Toyota Prado RZJ120R
4 cyl 2.7L 2/2003 - 9/2004



ALUMINIUM / PLASTIC
MANUAL

Core Height	650mm	Core Width	593mm
Core Thickness	16mm 1 Row	Inlet / Outlet	34 / 34
Oil Cooler	N/A		
Condenser	CNX7730	Receiver Drier	RDX0040

Notes:

E97CA

To suit Toyota Prado KDJ120R
4 cyl 3.0L Turbo Diesel 11/2006 - 12/2009



ALUMINIUM / PLASTIC
AUTOMATIC

Core Height	649mm	Core Width	588mm
Core Thickness	36mm 1 Row	Inlet / Outlet	39 / 39
Oil Cooler	250mm		
Condenser	CNX7740	Receiver Drier	RDX0040

Notes:

E97CM

To suit Toyota Prado KDJ120R
4 cyl 3.0L Turbo Diesel 11/2006 - 12/2009



ALUMINIUM / PLASTIC
MANUAL

Core Height	649mm	Core Width	588mm
Core Thickness	36mm 1 Row	Inlet / Outlet	39 / 39
Oil Cooler	N/A		
Condenser	CNX7730	Receiver Drier	RDX0040

Notes: Cross Flow

E98CM

To suit Toyota Prado KZJ120R
4 cyl 3.0L Turbo Diesel 2/2003 - 11/2006



ALUMINIUM / PLASTIC
MANUAL

Core Height	649mm	Core Width	588mm
Core Thickness	36mm 1 Row	Inlet / Outlet	39 / 39
Oil Cooler	N/A		
Condenser	CNX7730	Receiver Drier	RDX0040

Notes:

E77CA

To suit Toyota Prado KZJ95R
4 cyl 3.0L Turbo Diesel 3/2000 - 12/2002



ALUMINIUM / PLASTIC
AUTOMATIC

Core Height	575mm	Core Width	640mm
Core Thickness	36mm 2 Row	Inlet / Outlet	38 / 38
Oil Cooler	375mm		
Condenser	CNX3070	Receiver Drier	RDX284

Notes:

E77CM



To suit Toyota Prado KZJ95R
4 cyl 3.0L Turbo Diesel 3/2000 - 12/2002



Core Height	575mm	Core Width	640mm
Core Thickness	36mm 2 Row	Inlet / Outlet	39 / 39
Oil Cooler	N/A		
Condenser	CNX3070	Receiver Drier	RDX284

Notes:

E43CA



To suit Toyota Prado RZJ, VZJ95R
4 cyl & V6 7/1996 - 2/2003



Core Height	575mm	Core Width	640mm
Core Thickness	27mm 2 Row	Inlet / Outlet	35 / 35
Oil Cooler	375mm		
Condenser	CNX3070	Receiver Drier	RDX284

Notes:

E78CA



To suit Toyota Previa
4 cyl 2.4L 1/2000 - 12/2005 (NZ)



Core Height	450mm	Core Width	736mm
Core Thickness	27mm 1 Row	Inlet / Outlet	35 / 35
Oil Cooler	375mm		
Condenser	CNX1900	Receiver Drier	RDX0040

Notes:

TOY60172



To suit Toyota Previa
4 cyl 2.4L 1/1990 - 12/2000 (NZ)



Core Height	424mm	Core Width	668mm
Core Thickness	32mm 2 Row	Inlet / Outlet	38 / 38
Oil Cooler	325mm		
Condenser	CNX1070	Receiver Drier	RDX287

Notes:

E111CA



To suit Toyota Prius NHW20R
4 cyl 1.5L 10/2003 - 12/2009



Core Height	600mm	Core Width	351mm
Core Thickness	16mm 1 Row	Inlet / Outlet	32 / 22 32 / 22
Oil Cooler	N/A		
Condenser	CNX8881	Receiver Drier	RDX0280

Notes:

E86CA



To suit Toyota Prius NHW11R
4 cyl 1.5L 10/2001 - 10/2003



Core Height	600mm	Core Width	350mm
Core Thickness	20mm 1 Row	Inlet / Outlet	31 / 31
Oil Cooler	N/A		
Condenser		Receiver Drier	RDX0070

Notes:

E86CM

To suit Toyota Prius NHW11R
4 cyl 1.5L 10/2001 - 10/2003



Core Height	598mm	Core Width	358mm
Core Thickness	16mm 1 Row	Inlet / Outlet	31 / 31
Oil Cooler	N/A		
Condenser		Receiver Drier	RDX0070

Notes:

TOY1713

To suit Toyota Rav4 ACA33R
4 cyl 2.4L 2/2006 - 10/2008



Core Height	670mm	Core Width	400mm
Core Thickness	22mm 1 Row	Inlet / Outlet	39 / 39
Oil Cooler	275mm		
Condenser	CNX1000	Receiver Drier	RDX0070

Notes:

TOY60147

To suit Toyota Rav4 ACA20R, 23R
4 cyl 2.0 & 2.4L 7/2000 - 2/2006

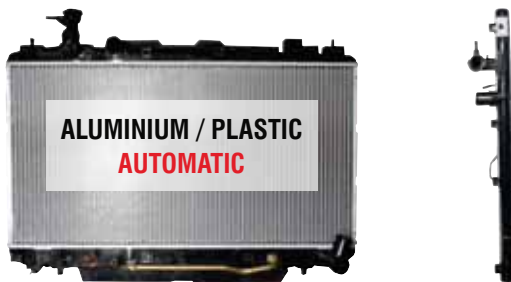

Core Height	375mm	Core Width	738mm
Core Thickness	24mm 1 Row	Inlet / Outlet	35 / 35
Oil Cooler	390mm		
Condenser	CNX2090	Receiver Drier	RDX0040

Notes:

TOY60145

To suit Toyota Rav4 SXA10, 11R
4 cyl 2.0L 7/1994 - 7/2000



Core Height	350mm	Core Width	708mm
Core Thickness	24mm 1 Row	Inlet / Outlet	33 / 33
Oil Cooler	400mm		
Condenser	CNX074	Receiver Drier	RDX281

Notes: Saddle Type Mount

TOY60146

To suit Toyota Rav4 SXA10, 11R
4 cyl 2.0L 7/1994 - 7/2000



Core Height	350mm	Core Width	708mm
Core Thickness	24mm 1 Row	Inlet / Outlet	33 / 33
Oil Cooler	N/A		
Condenser	CNX074	Receiver Drier	RDX281

Notes: Saddle Type Mount

TOY60140

To suit Toyota Rav4 SXA10, 11R
4 cyl 2.0L 7/1994 - 7/2000



Core Height	350mm	Core Width	708mm
Core Thickness	24mm 1 Row	Inlet / Outlet	33 / 33
Oil Cooler	400mm		
Condenser	CNX074	Receiver Drier	RDX281

Notes: Dowel Type Top Mount

TOY60141

To suit Toyota Rav4 SXA10, 11R
4 cyl 2.0L 7/1994 - 7/2000



ALUMINIUM / PLASTIC
MANUAL

Core Height	350mm	Core Width	708mm
Core Thickness	24mm 1 Row	Inlet / Outlet	33 / 33
Oil Cooler	N/A		
Condenser	CNX074	Receiver Drier	RDX281

Notes: Dowel Type Top Mount

E69CA

To suit Toyota Soarer JZZ31
6 cyl 3.0L 1/1990 - 12/1997



ALUMINIUM / PLASTIC
AUTOMATIC

Core Height	425mm	Core Width	737mm
Core Thickness	27mm 1 Row	Inlet / Outlet	35 / 35
Oil Cooler	325mm		
Condenser		Receiver Drier	

Notes:

E53CA

To suit Toyota Soarer UZZ31
V8 4.0L 2/1990 - 12/1998



ALUMINIUM / PLASTIC
AUTOMATIC

Core Height	425mm	Core Width	737mm
Core Thickness	27mm 1 Row	Inlet / Outlet	40 / 40
Oil Cooler	350mm		
Condenser		Receiver Drier	

Notes:

E59CA

To suit Toyota Spacia SR40R
4 cyl 2.0L 1/1998 - 1/2002



ALUMINIUM / PLASTIC
AUTOMATIC

Core Height	425mm	Core Width	680mm
Core Thickness	16mm 1 Row	Inlet / Outlet	33 / 33
Oil Cooler	380mm		
Condenser	CNX5550	Receiver Drier	RDX287

Notes:

E59CM

To suit Toyota Spacia SR40R
4 cyl 2.0L 1/1998 - 1/2002



ALUMINIUM / PLASTIC
MANUAL

Core Height	425mm	Core Width	680mm
Core Thickness	16mm 1 Row	Inlet / Outlet	33 / 33
Oil Cooler	N/A		
Condenser	CNX5550	Receiver Drier	RDX287

Notes:

TOY60218

To suit Toyota Sprinter
4 cyl 1.6L 1/1996 - 12/1997 (NZ)



COPPER / PLASTIC
AUTOMATIC

Core Height	350mm	Core Width	642mm
Core Thickness	16mm 1 Row	Inlet / Outlet	31 / 31
Oil Cooler	225mm		
Condenser	CNX060	Receiver Drier	RDX604

Notes:

15-TOY60218

revolution

To suit Toyota Sprinter
4 cyl 1.6L 1/1996 - 12/1997 (NZ)



Core Height	350mm	Core Width	642mm
Core Thickness	16mm 1 Row	Inlet / Outlet	31 / 31
Oil Cooler	225mm		
Condenser	CNX060	Receiver Drier	RDX604

Notes:

E29CA2

DENSO

To suit Toyota Sprinter
4 cyl 1.6L 1/1996 - 12/1997 (NZ)



Core Height	350mm	Core Width	640mm
Core Thickness	16mm 1 Row	Inlet / Outlet	31 / 31
Oil Cooler	225mm		
Condenser	CNX060	Receiver Drier	RDX604

Notes:

E52CA

DENSO

To suit Toyota Sprinter
4 cyl 1.6L 1/1991 - 12/2000



Core Height	350mm	Core Width	699mm
Core Thickness	16mm 1 Row	Inlet / Outlet	33 / 33
Oil Cooler	225mm		
Condenser	CNX4860	Receiver Drier	RDX604

Notes:

TOY60214

OEX

To suit Toyota Sprinter
4 cyl 1.6L 1/1987 - 12/1991



Core Height	325mm	Core Width	665mm
Core Thickness	16mm 1 Row	Inlet / Outlet	31 / 31
Oil Cooler	225mm		
Condenser	CNX056 / CNX059	Receiver Drier	RDX284 / RDX282

Notes: CNX056 & RDX282 - R12, CNX059 & CNX284 - R134A

15-TOY60214

revolution

To suit Toyota Sprinter
4 cyl 1.6L 1/1987 - 12/1991



Core Height	325mm	Core Width	665mm
Core Thickness	16mm 1 Row	Inlet / Outlet	31 / 31
Oil Cooler	225mm		
Condenser	CNX056	Receiver Drier	RDX284

Notes: CNX056 & RDX282 - R12, CNX059 & CNX284 - R134A

E54CA

DENSO

To suit Toyota Starlet EP91R
4 cyl 1.3L 3/1996 - 9/1999



Core Height	325mm	Core Width	641mm
Core Thickness	27mm 2 Row	Inlet / Outlet	29 / 29
Oil Cooler	275mm		
Condenser	CNX5920	Receiver Drier	RDX281

Notes:

TOY60172

To suit Toyota Tarago TCR10, 21R
4 cyl 2.4L 1/1990 - 6/2001



COPPER / PLASTIC
AUTOMATIC

Core Height	424mm	Core Width	668mm
Core Thickness	32mm 2 Row	Inlet / Outlet	38 / 38
Oil Cooler	325mm		
Condenser	CNX1070	Receiver Drier	RDX287

Notes:

TOY1103

To suit Toyota Tercel AL25
4 cyl 1.5L 10/1983 - 4/1989



COPPER / PLASTIC
MANUAL

Core Height	352mm	Core Width	488mm
Core Thickness	16mm 1 Row	Inlet / Outlet	33 / 33
Oil Cooler	N/A		
Condenser		Receiver Drier	RDX086

Notes:

E59CA

To suit Toyota Townace KR42 (SBV)
4 cyl 1.8L 2/1997 - 4/2004



ALUMINIUM / PLASTIC
AUTOMATIC

Core Height	425mm	Core Width	680mm
Core Thickness	16mm 1 Row	Inlet / Outlet	33 / 33
Oil Cooler	380mm		
Condenser	CNX5550	Receiver Drier	RDX287

Notes:

E59CM

To suit Toyota Townace KR42 (SBV)
4 cyl 1.8L 2/1997 - 4/2004



ALUMINIUM / PLASTIC
MANUAL

Core Height	425mm	Core Width	680mm
Core Thickness	16mm 1 Row	Inlet / Outlet	33 / 33
Oil Cooler	N/A		
Condenser	CNX5550	Receiver Drier	RDX287

Notes:

E32CA

To suit Toyota Vienta MCV20R
V6 3.0L 8/1997 - 9/2000



ALUMINIUM / PLASTIC
AUTOMATIC

Core Height	399mm	Core Width	737mm
Core Thickness	27mm 2 Row	Inlet / Outlet	35 / 35
Oil Cooler	375mm		
Condenser		Receiver Drier	RDX281

Notes:

TOY60232

To suit Toyota Windom
V6 3.0L 1/1991 - 12/1996 (NZ)



COPPER / PLASTIC
AUTOMATIC

Core Height	425mm	Core Width	715mm
Core Thickness	32mm 2 Row	Inlet / Outlet	34 / 34
Oil Cooler	375mm		
Condenser	CNX055	Receiver Drier	RDX281

Notes:

E47CM

To suit Toyota Starlet EP91R
4 cyl 1.3L 3/1996 - 9/1999



Core Height	325mm	Core Width	641mm
Core Thickness	16mm 1 Row	Inlet / Outlet	29 / 29
Oil Cooler	N/A		
Condenser	CNX5920	Receiver Drier	RDX281

Notes:

E74CA

To suit Toyota Supra JZA80
4 cyl 3.0L 1/1993 - 12/1998



Core Height	374mm	Core Width	642mm
Core Thickness	28mm 1 Row	Inlet / Outlet	35 / 35
Oil Cooler	375mm		
Condenser	CNX3330	Receiver Drier	RDX281

Notes:

E79CA

To suit Toyota Surf SSR, SSR-G, SSR-X
4 cyl 3.0L Turbo Diesel 1/1992 - 12/1997



Core Height	574mm	Core Width	641mm
Core Thickness	28mm 1 Row	Inlet / Outlet	39 / 39
Oil Cooler	375mm		
Condenser		Receiver Drier	

Notes:

E78CA

To suit Toyota Tarago ACR30R
4 cyl 2.4L 6/2000 - 3/2007



Core Height	450mm	Core Width	736mm
Core Thickness	27mm 1 Row	Inlet / Outlet	35 / 35
Oil Cooler	375mm		
Condenser	CNX1900	Receiver Drier	RDX0040

Notes:

TOY1140

To suit Toyota Tarago ACR50R, GSR50R
4 cyl 2.4L & V6 3.5L 3/2006 >



Core Height	670mm	Core Width	400mm
Core Thickness	27mm 1 Row	Inlet / Outlet	38 / 38
Oil Cooler	275mm		
Condenser	CNX1000	Receiver Drier	RDX0070

Notes: 2 x 10mm Bleeder Pipes

E51CA

To suit Toyota Tarago TCR10, 21R
4 cyl 2.4L 8/1990 - 6/2001



Core Height	425mm	Core Width	678mm
Core Thickness	16mm 1 Row	Inlet / Outlet	39 / 39
Oil Cooler	325mm		
Condenser	CNX1070	Receiver Drier	RDX287

Notes:

TOY1481

To suit Toyota Yaris NCP90, 93R
4 cyl 1.3 & 1.5L 10/2005 >



ALUMINIUM / PLASTIC
AUTOMATIC



Core Height	350mm	Core Width	475mm
Core Thickness	16mm 1 Row	Inlet / Outlet	32 / 32
Oil Cooler	225mm		
Condenser	CNX2361	Receiver Drier	RDX0040

Notes:

TOY1480

To suit Toyota Yaris NCP90, 93R
4 cyl 1.3 & 1.5L 10/2005 >



ALUMINIUM / PLASTIC
MANUAL



Core Height	350mm	Core Width	480mm
Core Thickness	16mm 1 Row	Inlet / Outlet	32 / 32
Oil Cooler	N/A		
Condenser	CNX2361	Receiver Drier	RDX0040

Notes:

VW26701

To suit Volkswagen Beetle
4 cyl 1.9L 11/2005 - 8/2007



ALUMINIUM / PLASTIC
AUTOMATIC & MANUAL



Core Height	650mm	Core Width	410mm
Core Thickness	34mm 2 Row	Inlet / Outlet	32 / 32
Oil Cooler	N/A		
Condenser		Receiver Drier	

Notes:

VW32010

To suit Volkswagen Beetle
4 cyl 1.6 & 2.0L 1/2000 - 10/2005



ALUMINIUM / PLASTIC
MANUAL



Core Height	655mm	Core Width	365mm
Core Thickness	32mm 1 Row	Inlet / Outlet	33 / 33
Oil Cooler	N/A		
Condenser	CNX858	Receiver Drier	RDX378

Notes:

VW16611

To suit Volkswagen Beetle
4 cyl 1.6, 2.0L Petrol & 1.9L Turbo Diesel
1/2000 - 4/2008



ALUMINIUM / PLASTIC
MANUAL



Core Height	650mm	Core Width	377mm
Core Thickness	32mm 1 Row	Inlet / Outlet	32 / 32
Oil Cooler	N/A		
Condenser	CNX858	Receiver Drier	RDX378

Notes:

VW13781

To suit Volkswagen Bora
4, 5 & 6 cyl 2.0, 2.3 & 2.8L 1/1999 - 11/2005



ALUMINIUM / PLASTIC
AUTOMATIC & MANUAL



Core Height	650mm	Core Width	415mm
Core Thickness	24mm 2 Row	Inlet / Outlet	32 / 32
Oil Cooler	N/A		
Condenser	CNX860	Receiver Drier	RDX378

Notes:

VW74031

To suit Volkswagen Caddy
4 cyl 1.9L Turbo Diesel 1/2006 >



ALUMINIUM / PLASTIC
AUTOMATIC & MANUAL

Core Height	650mm	Core Width	451mm
Core Thickness	34mm 2 Row	Inlet / Outlet	32 / 32
Oil Cooler	N/A		
Condenser	CNX870	Receiver Drier	RDX370

Notes:

VW81091

To suit Volkswagen Caddy
4 cyl 1.6L 5/2006 - 7/2008



ALUMINIUM / PLASTIC
AUTOMATIC & MANUAL

Core Height	647mm	Core Width	406mm
Core Thickness	26mm 1 Row	Inlet / Outlet	32 / 32
Oil Cooler	N/A		
Condenser	CNX870	Receiver Drier	RDX370

Notes:

VW65121

To suit Volkswagen Caddy
4 cyl 1.9L Turbo Diesel 1/2005 >



ALUMINIUM / PLASTIC
AUTOMATIC & MANUAL

Core Height	650mm	Core Width	451mm
Core Thickness	34mm 2 Row	Inlet / Outlet	32 / 32
Oil Cooler	N/A		
Condenser	CNX870	Receiver Drier	RDX370

Notes:

VW26701

To suit Volkswagen Caddy
4 cyl 1.9L Turbo Diesel 1/2005 >



ALUMINIUM / PLASTIC
AUTOMATIC & MANUAL

Core Height	650mm	Core Width	410mm
Core Thickness	34mm 2 Row	Inlet / Outlet	32 / 32
Oil Cooler	N/A		
Condenser		Receiver Drier	

Notes:

VW74031

To suit Volkswagen EOS
4 cyl 2.0L Turbo Petrol 3/2007 >



ALUMINIUM / PLASTIC
AUTOMATIC & MANUAL

Core Height	650mm	Core Width	451mm
Core Thickness	34mm 2 Row	Inlet / Outlet	32 / 32
Oil Cooler	N/A		
Condenser	CNX870	Receiver Drier	RDX370

Notes:

VW65121

To suit Volkswagen EOS, Golf
4 cyl 2.0L & 1.9L Turbo Diesel D 8/2004 >



ALUMINIUM / PLASTIC
AUTOMATIC & MANUAL

Core Height	650mm	Core Width	451mm
Core Thickness	34mm 2 Row	Inlet / Outlet	32 / 32
Oil Cooler	N/A		
Condenser	CNX870	Receiver Drier	RDX370

Notes:

VW74031

To suit Volkswagen Golf

4 cyl 1.4L Supercharged & 2.0L Turbo Petrol
5/2005 - 1/2010



Core Height	650mm	Core Width	451mm
Core Thickness	34mm 2 Row	Inlet / Outlet	32 / 32
Oil Cooler	N/A		
Condenser	CNX870	Receiver Drier	RDX370

Notes:

VW74041

To suit Volkswagen Golf

4 cyl 2.0L Turbo Diesel & Petrol 8/2004 >



Core Height	650mm	Core Width	455mm
Core Thickness	32mm 1 Row	Inlet / Outlet	32 / 32
Oil Cooler	N/A		
Condenser	CNX870	Receiver Drier	RDX370

Notes:

VW26701

To suit Volkswagen Golf

4 cyl 1.4L Supercharged & 1.4, 1.6 & 1.9
Turbo Diesel 8/2004 >



Core Height	650mm	Core Width	410mm
Core Thickness	34mm 2 Row	Inlet / Outlet	32 / 32
Oil Cooler	N/A		
Condenser	CNX881	Receiver Drier	RDX913

Notes:

VW81091

To suit Volkswagen Golf

4 cyl 1.6 & 2.0L 10/2001 - 1/2010



Core Height	647mm	Core Width	406mm
Core Thickness	26mm 1 Row	Inlet / Outlet	32 / 32
Oil Cooler	N/A		
Condenser	CNX870	Receiver Drier	RDX370

Notes:

VW13781

To suit Volkswagen Golf

4 cyl 1.4, 1.6, 1.8 & 2.0L inc Supercharged
10/1998 - 8/2004



Core Height	650mm	Core Width	415mm
Core Thickness	24mm 2 Row	Inlet / Outlet	32 / 32
Oil Cooler	N/A		
Condenser	CNX860	Receiver Drier	RDX378

Notes:

VW13301

To suit Volkswagen Golf

4 cyl 1.8L Convertible 8/1990 - 11/1999



Core Height	525mm	Core Width	320mm
Core Thickness	34mm 2 Row	Inlet / Outlet	32 / 32
Oil Cooler	N/A		
Condenser	CNX861	Receiver Drier	RDX908

Notes:

VW14041

To suit Volkswagen Golf
4 cyl 1.8 & 2.0L & 1.9L Turbo Diesel
8/1990 - 7/2000



Core Height	630mm	Core Width	360mm
Core Thickness	32mm 2 Row	Inlet / Outlet	32 / 32
Oil Cooler	N/A		
Condenser	CNX861	Receiver Drier	RDX908

Notes:

VW14541

To suit Volkswagen Golf
V6 2.8L 3/1994 - 10/1998



Core Height	625mm	Core Width	350mm
Core Thickness	32mm 1 Row	Inlet / Outlet	32 / 32
Oil Cooler	N/A		
Condenser	CNX861	Receiver Drier	RDX908

Notes:

VW13311

To suit Volkswagen Golf SII
4 cyl 1.6 & 1.8L inc Turbo 1984 - 1992



Core Height	675mm	Core Width	320mm
Core Thickness	34mm 2 Row	Inlet / Outlet	32 / 32
Oil Cooler	N/A		
Condenser		Receiver Drier	

Notes:

VW81091

To suit Volkswagen Jetta
4 cyl 2.0L 2/2006 >



Core Height	647mm	Core Width	406mm
Core Thickness	26mm 1 Row	Inlet / Outlet	32 / 32
Oil Cooler	N/A		
Condenser	CNX870	Receiver Drier	RDX370

Notes:

VW74041

To suit Volkswagen Jetta
4 cyl 2.0L Turbo Diesel & Petrol 1/2006 >



Core Height	650mm	Core Width	455mm
Core Thickness	32mm 1 Row	Inlet / Outlet	32 / 32
Oil Cooler	N/A		
Condenser	CNX870	Receiver Drier	RDX370

Notes:

VW74031

To suit Volkswagen Jetta
4 cyl 2.0L Turbo Petrol 2/2006 - 2/2009



Core Height	650mm	Core Width	451mm
Core Thickness	34mm 2 Row	Inlet / Outlet	32 / 32
Oil Cooler	N/A		
Condenser	CNX870	Receiver Drier	RDX370

Notes:

VW19701

To suit Volkswagen LT35, LT46
4 & 5 cyl 2.5 & 2.8L Turbo Diesel
4/2003 - 2/2007



ALUMINIUM / PLASTIC
MANUAL

Core Height	680mm	Core Width	415mm
Core Thickness	34mm 2 Row	Inlet / Outlet	38 / 38
Oil Cooler	N/A		
Condenser	CNX854	Receiver Drier	

Notes:

VW20591

To suit Volkswagen Passat
4 cyl 1.8L inc Turbo 3/1998 - 12/2002



ALUMINIUM / PLASTIC
MANUAL

Core Height	630mm	Core Width	397mm
Core Thickness	36mm 1 Row	Inlet / Outlet	32 / 32
Oil Cooler	N/A		
Condenser	CNX869	Receiver Drier	RDX6549

Notes:

AUD16621

To suit Volkswagen Passat
4 cyl 1.8L Turbo 3/1998 - 12/2002



ALUMINIUM / PLASTIC
AUTOMATIC

Core Height	630mm	Core Width	395mm
Core Thickness	32mm 1 Row	Inlet / Outlet	42 / 42
Oil Cooler	300mm		
Condenser	CNX864	Receiver Drier	RDX375

Notes: Clip on Fittings. Sensor Port on P/S

VW14541

To suit Volkswagen Passat
V6 2.8L 8/1995 - 4/1998



ALUMINIUM / PLASTIC
MANUAL

Core Height	625mm	Core Width	375mm
Core Thickness	32mm 1 Row	Inlet / Outlet	32 / 32
Oil Cooler	N/A		
Condenser	CNX861	Receiver Drier	RDX908

Notes:

VW81091

To suit Volkswagen Polo
4 cyl 1.4L 1/2007 >



ALUMINIUM / PLASTIC
AUTOMATIC & MANUAL

Core Height	647mm	Core Width	406mm
Core Thickness	26mm 1 Row	Inlet / Outlet	32 / 32
Oil Cooler	N/A		
Condenser	CNX870	Receiver Drier	RDX370

Notes:

VW26701

To suit Volkswagen Polo
4 cyl 1.4L 1/2006 >



ALUMINIUM / PLASTIC
AUTOMATIC & MANUAL

Core Height	650mm	Core Width	410mm
Core Thickness	34mm 2 Row	Inlet / Outlet	32 / 32
Oil Cooler	N/A		
Condenser		Receiver Drier	RDX6806

Notes:

VW17701



To suit Volkswagen Polo

4 cyl Petrol 1.4, 1.6L & 1.9L Turbo Diesel
9/2000 - 8/2007



ALUMINIUM / PLASTIC
MANUAL

Core Height	635mm	Core Width	405mm
Core Thickness	26mm 2 Row	Inlet / Outlet	32 / 32
Oil Cooler	N/A		
Condenser	CNX860	Receiver Drier	RDX6806

Notes:

VW74041



To suit Volkswagen Tiguan

4 cyl 2.0L Turbo Diesel & 4 cyl 2.0L Petrol
5/2008 >



ALUMINIUM / PLASTIC
MANUAL

Core Height	650mm	Core Width	455mm
Core Thickness	32mm 1 Row	Inlet / Outlet	32 / 32
Oil Cooler	N/A		
Condenser	CNX870	Receiver Drier	RDX370

Notes:

AUD19001



To suit Volkswagen Touareg

V6 3.0L Turbo Diesel 9/2006 >



ALUMINIUM / PLASTIC
AUTOMATIC & MANUAL

Core Height	710mm	Core Width	550mm
Core Thickness	40mm 1 Row	Inlet / Outlet	38 / 38
Oil Cooler	N/A		
Condenser	CNX910	Receiver Drier	RDX922

Notes:

AUD19001



To suit Volkswagen Touareg

V6 3.6L & V8 4.2L Petrol 9/2003 >



ALUMINIUM / PLASTIC
AUTOMATIC & MANUAL

Core Height	710mm	Core Width	550mm
Core Thickness	40mm 1 Row	Inlet / Outlet	38 / 38
Oil Cooler	N/A		
Condenser	CNX910	Receiver Drier	RDX922

Notes:

VW19181



To suit Volkswagen Transporter T5

4 cyl 2.0L Petrol & 1.9L Turbo Diesel
1/2004 - 12/2009



ALUMINIUM / PLASTIC
AUTOMATIC

Core Height	710mm	Core Width	470mm
Core Thickness	24mm 1 Row	Inlet / Outlet	32 / 32
Oil Cooler	N/A		
Condenser	CNX878	Receiver Drier	RDX922

Notes:

VW19161



To suit Volkswagen Transporter T5 Multivan

4 cyl 2.0L Petrol & 5 cyl 2.5L Turbo Diesel
9/2004 - 7/2008



ALUMINIUM / PLASTIC
AUTOMATIC & MANUAL

Core Height	710mm	Core Width	470mm
Core Thickness	32mm 1 Row	Inlet / Outlet	32 / 32
Oil Cooler	N/A		
Condenser	CNX878	Receiver Drier	RDX922

Notes:

VW19171

To suit Volkswagen Transporter T5 Multivan
V6 3.2L 1/2004 - 6/2008



Core Height	710mm	Core Width	470mm
Core Thickness	32mm 1 Row	Inlet / Outlet	32 / 32
Oil Cooler	N/A		
Condenser	CNX878	Receiver Drier	RDX922

Notes:

VW73771

To suit Volkswagen Transporter T4
5 cyl 2.4L Diesel & 2.0 & 2.5L Petrol
1/1994 - 9/1999



Core Height	720mm	Core Width	390mm
Core Thickness	24mm 1 Row	Inlet / Outlet	32 / 32
Oil Cooler	N/A		
Condenser	CNX5810	Receiver Drier	RDX281

Notes:

VW14481

To suit Volkswagen Transporter T4
5 cyl 2.5L Petrol & 2.4L Diesel 1/1993 - 9/2004



Core Height	720mm	Core Width	350mm
Core Thickness	33mm 1 Row	Inlet / Outlet	32 / 32
Oil Cooler	N/A		
Condenser		Receiver Drier	

Notes:

VW13631

To suit Volkswagen Transporter T3 Combi
4 cyl 1.9 & 2.1L 1/1984 - 12/1992



Core Height	565mm	Core Width	425mm
Core Thickness	62mm 1 Row	Inlet / Outlet	32 / 32
Oil Cooler	N/A		
Condenser		Receiver Drier	

Notes:

VOL62100

To suit Volvo 240 - 760
4 cyl & V6 2.1, 2.3 & 2.8L inc Turbo
1/1975 - 9/1996



Core Height	450mm	Core Width	415mm
Core Thickness	45mm 3 Row	Inlet / Outlet	34 / 34
Oil Cooler	195mm		
Condenser		Receiver Drier	RDX027

Notes:

VOL09031

To suit Volvo 440
4 cyl 2.0L 11/1993 - 9/1996



Core Height	536mm	Core Width	368mm
Core Thickness	32mm 2 Row	Inlet / Outlet	30 / 30
Oil Cooler	N/A		
Condenser		Receiver Drier	

Notes:

VOL06741



To suit Volvo 850
5 cyl 2.3 & 2.4L inc Turbo 10/1992 - 3/1998



Core Height	590mm	Core Width	390mm
Core Thickness	33mm 1 Row	Inlet / Outlet	37 / 37
Oil Cooler	285mm		
Condenser	CNX640	Receiver Drier	RDX307

Notes: Single Oil Cooler

VOL26761



To suit Volvo 850, C70, S70, V70
5 cyl 2.3, 2.4, 2.5 & 3.0L inc Turbo
10/1992 - 3/1998



Core Height	590mm	Core Width	390mm
Core Thickness	32mm 1 Row	Inlet / Outlet	38 / 38
Oil Cooler	280/320mm		
Condenser		Receiver Drier	

Notes: Twin Oil Coolers

VOL20791



To suit Volvo 960
V6 2.8L & 6 cyl 2.9L 11/1990 - 3/1998



Core Height	590mm	Core Width	500mm
Core Thickness	34mm 1 Row	Inlet / Outlet	37 / 37
Oil Cooler	N/A		
Condenser		Receiver Drier	RDX303

Notes:

VOL29601



To suit Volvo C30, C30M
4 & 5 cyl 2.0 & 2.4L inc Turbo 10/2008 >



Core Height	650mm	Core Width	375mm
Core Thickness	24mm 1 Row	Inlet / Outlet	32 / 32
Oil Cooler	N/A		
Condenser		Receiver Drier	

Notes:

VOL06741



To suit Volvo C70
5 cyl 2.3, 2.4 & 2.5L inc Turbo 3/1998 - 10/2008



Core Height	590mm	Core Width	390mm
Core Thickness	33mm 1 Row	Inlet / Outlet	37 / 37
Oil Cooler	285mm		
Condenser	CNX640	Receiver Drier	RDX307

Notes: Single Oil Cooler

VOL74201



To suit Volvo C70, S70, V70, XC60, 90
5 & 6 cyl 2.3, 2.4 & 2.5L 3/1998 - 10/2008



Core Height	590mm	Core Width	388mm
Core Thickness	40mm	Inlet / Outlet	38 / 38
Oil Cooler	280mm		
Condenser	CNX640	Receiver Drier	RDX307

Notes:

VOL58111

To suit Volvo FL6, FL608, FL609
6 cyl 5.5L Diesel 1/1997 >



ALUMINIUM /
PLASTIC
AUTOMATIC

Core Height	815mm	Core Width	560mm
Core Thickness	42mm	Inlet / Outlet	60 / 60
Oil Cooler	N/A		
Condenser		Receiver Drier	

Notes:

VOL58101

To suit Volvo FL6, FL608, FL609
6 cyl 5.5L Diesel 1/1997 >



ALUMINIUM /
PLASTIC
AUTOMATIC

Core Height	715mm	Core Width	560mm
Core Thickness	42mm	Inlet / Outlet	48 / 48
Oil Cooler	N/A		
Condenser		Receiver Drier	

Notes:

VOL26551

To suit Volvo FM7, FM10, FM12 7
10.0 & 12.0L 1993 >



ALUMINIUM /
PLASTIC
AUTOMATIC

Core Height	900mm	Core Width	730mm
Core Thickness	50mm	Inlet / Outlet	64 / 64
Oil Cooler	N/A		
Condenser		Receiver Drier	

Notes:

VOL75001

To suit Volvo FM9, FM12
9.0 & 12.0L 1998 >



ALUMINIUM /
PLASTIC
AUTOMATIC

Core Height	900mm	Core Width	728mm
Core Thickness	48mm 2 Row	Inlet / Outlet	64 / 64
Oil Cooler	N/A		
Condenser	CNX654	Receiver Drier	

Notes:

VOL74791

To suit Volvo FM9, FM12, FH12, FH16
9.0, 12.0 & 16.0L 1993 >



ALUMINIUM /
PLASTIC
MANUAL

Core Height	900mm	Core Width	870mm
Core Thickness	48mm 2 Row	Inlet / Outlet	64 / 64
Oil Cooler	N/A		
Condenser	CNX640	Receiver Drier	RDX307

Notes:

VOL29601

To suit Volvo S40, V50
5 cyl 2.0, 2.4 & 2.5L inc Turbo 2/2004 >



ALL ALUMINIUM
AUTOMATIC & MANUAL

Core Height	650mm	Core Width	375mm
Core Thickness	24mm 1 Row	Inlet / Outlet	32 / 32
Oil Cooler	N/A		
Condenser	CNX649	Receiver Drier	RDX608

Notes:

VOL74131

To suit Volvo S40

4 cyl 1.8 & 2.0L inc Turbo 3/1997 - 12/2004



Core Height	400mm	Core Width	678mm
Core Thickness	26mm	Inlet / Outlet	35 / 35
Oil Cooler	N/A		
Condenser	CNX649	Receiver Drier	RDX608

Notes:

VOL74231

To suit Volvo S40, S60, V50, V70, XC70, XC90

5 & 6 cyl inc Turbo 3/1997 - 3/2008



Core Height	620mm	Core Width	420mm
Core Thickness	42mm 1 Row	Inlet / Outlet	37 / 37
Oil Cooler	330mm		
Condenser	CNX640 / CNX647	Receiver Drier	RDX307

Notes:

VOL74171

To suit Volvo S40, V40

4 cyl 1.8, 1.9 & 2.0L inc Turbo 3/1997 - 12/2004



Core Height	622mm	Core Width	330mm
Core Thickness	27mm	Inlet / Outlet	32 / 32
Oil Cooler	N/A		
Condenser	CNX649	Receiver Drier	RDX608

Notes:

VOL06741

To suit Volvo S70, V70

5 & 6 cyl 2.3, 2.4, 2.5 & 3.0L inc Turbo 3/1997 - 1/2008



Core Height	590mm	Core Width	390mm
Core Thickness	33mm 1 Row	Inlet / Outlet	37 / 37
Oil Cooler	285mm		
Condenser	CNX640	Receiver Drier	RDX307

Notes: Single Oil Cooler

VOL20791

To suit Volvo S90, V90

6 cyl 2.9L 3/1997 - 2/1999



Core Height	590mm	Core Width	500mm
Core Thickness	34mm 1 Row	Inlet / Outlet	37 / 37
Oil Cooler	N/A		
Condenser		Receiver Drier	RDX303

Notes:

Core Height		Core Width	
Core Thickness		Inlet / Outlet	
Oil Cooler			
Condenser		Receiver Drier	

ALF46561CAC

To suit Alfa Romeo 147/GT
1.9L JTD 11/2005 >



Core Height	240mm	Core Width	172mm
Core Thickness	62mm	Inlet / Outlet	
Oil Cooler			
Condenser		Receiver Drier	

Notes:

VW46161CAC

To suit Audi A3
2.0L Turbo Diesel 6/2005 >



Core Height	617mm	Core Width	407mm
Core Thickness	32mm	Inlet / Outlet	
Oil Cooler			
Condenser		Receiver Drier	

Notes:

AUD46191CAC

To suit Audi A4/A5 8K2
1.8 & 2.0L 11/2007 >



Core Height	665mm	Core Width	142mm
Core Thickness	64mm	Inlet / Outlet	
Oil Cooler			
Condenser		Receiver Drier	

Notes:

VW29571CAC

To suit Audi Q7
V6 3.0L Turbo Diesel 2006 >



Core Height	300mm	Core Width	284mm
Core Thickness	50mm	Inlet / Outlet	64 / 77
Oil Cooler			
Condenser		Receiver Drier	

Notes: R/H Fit. Clip on fittings both pipes

BMW31791CAC

To suit BMW 1 & 3 Series E87, E90, E91
2.0L 9/2004 >



Core Height	508mm	Core Width	100mm
Core Thickness	85mm	Inlet / Outlet	
Oil Cooler			
Condenser		Receiver Drier	

Notes:

BMW23091CAC

To suit BMW 3 Series E87, E90, E91
6 cyl 2.5L 5/1991 >



Core Height	515mm	Core Width	127mm
Core Thickness	40mm	Inlet / Outlet	
Oil Cooler			
Condenser		Receiver Drier	

Notes:

DAF23771CAC

To suit DAF 95 XF
11.6, 12.6 & 14.0L 2002 - 12/2006



Core Height	554mm	Core Width	852mm
Core Thickness	52mm	Inlet / Outlet	
Oil Cooler			
Condenser		Receiver Drier	

Notes:

DAF24001CAC

To suit DAF 95 XF
11.6, 12.6 & 14.0L 1998 - 12/2006



Core Height	608mm	Core Width	852mm
Core Thickness	52mm	Inlet / Outlet	
Oil Cooler			
Condenser		Receiver Drier	

Notes:

FIA46021CAC

To suit Fiat Ducato
4 cyl 3.0L Turbo Diesel 2/2007 >



Core Height	740mm	Core Width	127mm
Core Thickness	64mm	Inlet / Outlet	
Oil Cooler			
Condenser		Receiver Drier	

Notes:

FOR46471CAC

To suit Ford Focus LT
4 cyl 2.0L Petrol & 5 cyl 2.5L Turbo Diesel
7/2007 >



Core Height	657mm	Core Width	157mm
Core Thickness	40mm	Inlet / Outlet	
Oil Cooler			
Condenser		Receiver Drier	

Notes:

FOR65101CAC

To suit Ford Transit VM
4 cyl 2.2 Petrol & 2.4L Turbo Diesel 3/2006 >



Core Height	398mm	Core Width	147mm
Core Thickness	62mm	Inlet / Outlet	
Oil Cooler			
Condenser		Receiver Drier	

Notes:

IVE76771CAC

To suit Iveco Daily II
2.8L Turbo Diesel 2002 >



Core Height	475mm	Core Width	192mm
Core Thickness	65mm	Inlet / Outlet	61 / 61
Oil Cooler			
Condenser		Receiver Drier	

Notes:

IVE27601CAC

To suit Iveco Daily I

4 cyl 2.8L inc Turbo 1998 - 2002



Core Height	630mm	Core Width	204mm
Core Thickness	65mm	Inlet / Outlet	
Oil Cooler			
Condenser		Receiver Drier	

Notes:

IVE27531CAC

To suit Iveco Daily I

4 cyl 2.5L 1991 - 1998



Core Height	630mm	Core Width	217mm
Core Thickness	40mm	Inlet / Outlet	
Oil Cooler			
Condenser		Receiver Drier	

Notes:

IVE24271CAC

To suit Iveco Eurocargo Stralis

4 cyl 3.9L & 6 cyl 10.3L Turbo Diesel 2000 - 2003



Core Height	652mm	Core Width	772mm
Core Thickness	52mm	Inlet / Outlet	90 / 90
Oil Cooler			
Condenser		Receiver Drier	

Notes:

IVE76761CAC

To suit Iveco Eurocargo 150 - 320

6 cyl 7.7L 1/1992 >



Core Height	540mm	Core Width	582mm
Core Thickness	57mm	Inlet / Outlet	
Oil Cooler			
Condenser		Receiver Drier	

Notes:

IVE76741CAC

To suit Iveco Eurocargo

6 cyl 3.9 & 5.9L 1/1991 >



Core Height	540mm	Core Width	438mm
Core Thickness	57mm	Inlet / Outlet	
Oil Cooler			
Condenser		Receiver Drier	

Notes:

IVE58131CAC

To suit Iveco Eurostar 100 E21

2002 >



Core Height	532mm	Core Width	440mm
Core Thickness	50mm	Inlet / Outlet	74 / 74
Oil Cooler			
Condenser		Receiver Drier	

Notes:

IVE24031CAC

To suit Iveco Eurostar

6 cyl 17.2L Turbo Diesel 1/1996 - 1/2002



Core Height	650mm	Core Width	712mm
Core Thickness	52mm	Inlet / Outlet	
Oil Cooler			
Condenser		Receiver Drier	

Notes:

IVE24101CAC

To suit Iveco Eurotech

6 cyl 10.3L 2/2001 - 1/2008



Core Height	652mm	Core Width	712mm
Core Thickness	52mm	Inlet / Outlet	89 / 89
Oil Cooler			
Condenser		Receiver Drier	

Notes:

IVE24251CAC

To suit Iveco Stralis

6 cyl 10.3 & 12.9L Turbo Diesel 3/2005 >

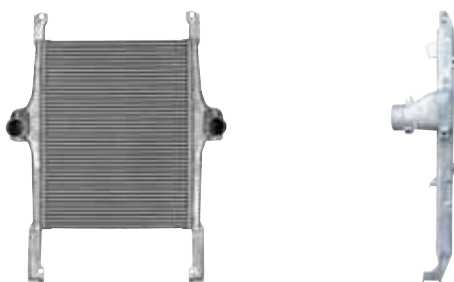

Core Height	652mm	Core Width	872mm
Core Thickness	52mm	Inlet / Outlet	90 / 90
Oil Cooler			
Condenser		Receiver Drier	

Notes:

IVE24301CAC

To suit Iveco Stralis

6 cyl 7.8L Turbo Petrol & Diesel 1/2005 >



Core Height	651mm	Core Width	772mm
Core Thickness	50mm	Inlet / Outlet	
Oil Cooler			
Condenser		Receiver Drier	

Notes:

PET002-4CAC

To suit Kenworth T908



Core Height	892mm	Core Width	673mm
Core Thickness	67mm	Inlet / Outlet	113 / 113
Oil Cooler			
Condenser		Receiver Drier	

Notes:

MAC27541CAC

To suit Mack Magnum

12.0 & 16.4L 4/1996 >

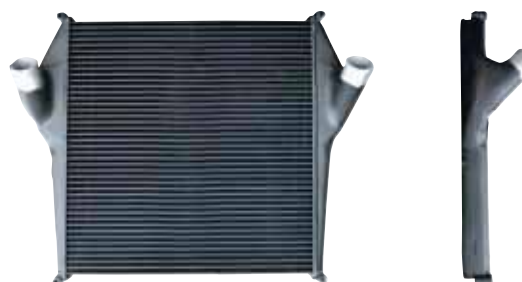

Core Height	757mm	Core Width	783mm
Core Thickness	68mm	Inlet / Outlet	90 / 90
Oil Cooler			
Condenser		Receiver Drier	

Notes:

REN24071CAC

To suit Mack Premium
9.8 & 11.1L 4/1996 >



Core Height	593mm	Core Width	812mm
Core Thickness	52mm	Inlet / Outlet	
Oil Cooler			
Condenser		Receiver Drier	

Notes:

REN58171CAC

To suit Mack Vision
12.0 & 16.4L 4/1996 >



Core Height	692mm	Core Width	692mm
Core Thickness	50mm	Inlet / Outlet	
Oil Cooler			
Condenser		Receiver Drier	

Notes:

MAN24351CAC

To suit Man Bus
Gas Powered



Core Height	752mm	Core Width	612mm
Core Thickness	66mm	Inlet / Outlet	
Oil Cooler			
Condenser		Receiver Drier	

Notes:

MAN23741CAC

To suit Man F2000
10.0, 12.0 & 13.0L 1/1994 >



Core Height	652mm	Core Width	612mm
Core Thickness	66mm	Inlet / Outlet	
Oil Cooler			
Condenser		Receiver Drier	

Notes:

MER24051CAC

To suit Mercedes-Benz Actros SK
14.6L 1996 >



Core Height	752mm	Core Width	652mm
Core Thickness	52mm	Inlet / Outlet	
Oil Cooler			
Condenser		Receiver Drier	

Notes:

MER24061CAC

To suit Mercedes-Benz Actros
11.9 & 15.9L 2003 >



Core Height	752mm	Core Width	852mm
Core Thickness	66mm	Inlet / Outlet	
Oil Cooler			
Condenser		Receiver Drier	

Notes:

MER58151CAC

To suit Mercedes-Benz Atego
4.2, 4.8 & 6.4L 2001 >



Core Height	558mm	Core Width	794mm
Core Thickness	68mm	Inlet / Outlet	86 / 86
Oil Cooler			
Condenser		Receiver Drier	

Notes:

MER23791CAC

To suit Mercedes-Benz Atego
4.2, 4.8 & 6.4L 1/1998 >



Core Height	572mm	Core Width	432mm
Core Thickness	52mm	Inlet / Outlet	
Oil Cooler			
Condenser		Receiver Drier	

Notes:

MER24391CAC

To suit Mercedes-Benz EVO Bus
12.0L 10/1999 >



Core Height	931mm	Core Width	732mm
Core Thickness	66mm	Inlet / Outlet	
Oil Cooler			
Condenser		Receiver Drier	

Notes:

MER23731CAC

To suit Mercedes-Benz LK LN2 Truck
4.2L 1/1984 - 12/1998



Core Height	420mm	Core Width	552mm
Core Thickness	52mm	Inlet / Outlet	
Oil Cooler			
Condenser		Receiver Drier	

Notes:

MER24011CAC

To suit Mercedes-Benz MK SK Truck
9.6, 10.9, 12.7, 14.6 & 18.3L 7/1987 >



Core Height	593mm	Core Width	792mm
Core Thickness	52mm	Inlet / Outlet	
Oil Cooler			
Condenser		Receiver Drier	

Notes:

MER20391CAC

To suit Mercedes-Benz Sprinter
4 cyl 2.2 & 2.7L 4/2000 >



Core Height	717mm	Core Width	255mm
Core Thickness	30mm	Inlet / Outlet	
Oil Cooler			
Condenser		Receiver Drier	

Notes:

MER46331CAC

To suit Mercedes-Benz W203 S203 C-Class
1.8, 2.0, 2.2 & 2.3L 5/2000 >



Core Height	650mm	Core Width	127mm
Core Thickness	50mm	Inlet / Outlet	
Oil Cooler			
Condenser		Receiver Drier	

Notes:

MER23141CAC

To suit Mercedes-Benz W210 S210
E200 - E270
2.0, 2.2, 2.7L 6/1998 >



Core Height	562mm	Core Width	113mm
Core Thickness	52mm	Inlet / Outlet	
Oil Cooler			
Condenser		Receiver Drier	

Notes:

MER23131CAC

To suit Mercedes-Benz W210 S210
E200 - E290
2.0, 2.2, 2.5 & 2.8L 6/1996 >



Core Height	562mm	Core Width	113mm
Core Thickness	52mm	Inlet / Outlet	
Oil Cooler			
Condenser		Receiver Drier	

Notes:

MER23391CAC

To suit Mercedes-Benz W211 S211
E200 - E280
1.8, 2.7, 3.0 & 3.2L 3/2002 >



Core Height	650mm	Core Width	113mm
Core Thickness	66mm	Inlet / Outlet	
Oil Cooler			
Condenser		Receiver Drier	

Notes:

MER24121CAC

To suit Mercedes-Benz W638 Vito 108 112
2.2L 3/1999 - 7/2003

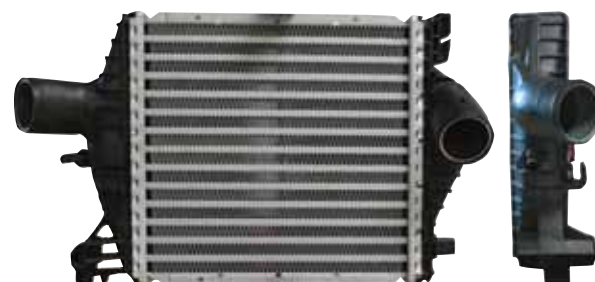

Core Height	290mm	Core Width	280mm
Core Thickness	50mm	Inlet / Outlet	
Oil Cooler			
Condenser		Receiver Drier	

Notes:

MER23531CAC

To suit Mercedes-Benz W639
Viano Vito 109 115CDI
2.1L 9/2003 >



Core Height	633mm	Core Width	158mm
Core Thickness	50mm	Inlet / Outlet	
Oil Cooler			
Condenser		Receiver Drier	

Notes:

MER23521CAC

To suit Mercedes-Benz W639 Vito 109CDI
2.1L 9/2003 >



Core Height	633mm	Core Width	113mm
Core Thickness	50mm	Inlet / Outlet	
Oil Cooler			
Condenser		Receiver Drier	

Notes:

MER46491CAC

To suit Mercedes-Benz W639
Viano Vito 109 - 120
2.1 & 3.0L 7/2006 >



Core Height	633mm	Core Width	158mm
Core Thickness	64mm	Inlet / Outlet	
Oil Cooler			
Condenser		Receiver Drier	

Notes:

MER24291CAC

To suit Mercedes-Benz W903 904
Sprinter 308 - 316, 408 - 416
4/2000 - 5/2006



Core Height	633mm	Core Width	232mm
Core Thickness	50mm	Inlet / Outlet	
Oil Cooler			
Condenser		Receiver Drier	

Notes:

MIN23431CAC

To suit Mini Cooper R50, R52, R53, R56
1.6L 3/2002 >



Core Height	277mm	Core Width	158mm
Core Thickness	50mm	Inlet / Outlet	
Oil Cooler			
Condenser		Receiver Drier	

Notes:

MIN46451CAC

To suit Mini Cooper R55, R56, R57
1.6L Turbo Diesel 10/2007 >



Core Height	540mm	Core Width	82mm
Core Thickness	64mm	Inlet / Outlet	
Oil Cooler			
Condenser		Receiver Drier	

Notes:

J57Q

To suit Mitsubishi Triton ML
4 cyl 3.2L Turbo Diesel 1/2006 >



Core Height	275mm	Core Width	225mm
Core Thickness	49mm	Inlet / Outlet	54 / 52
Oil Cooler			
Condenser		Receiver Drier	

Notes:

NIS46041CAC

To suit Nissan Navara D40
4 cyl 2.5L Turbo Diesel 5/2005 >



Core Height	445mm	Core Width	188mm
Core Thickness	64mm	Inlet / Outlet	
Oil Cooler			
Condenser		Receiver Drier	

Notes:

NIS46041CAC

To suit Nissan Pathfinder R51
4 cyl 2.5L Turbo Diesel 5/2005 >



Core Height	445mm	Core Width	188mm
Core Thickness	64mm	Inlet / Outlet	
Oil Cooler			
Condenser		Receiver Drier	

Notes:

NIS46611CAC

To suit Nissan X-Trail T31
4 cyl 2.0L Turbo Diesel 10/2007 >



Core Height	654mm	Core Width	157mm
Core Thickness	64mm	Inlet / Outlet	
Oil Cooler			
Condenser		Receiver Drier	

Notes:

VW23471CAC

To suit Porsche Cayenne
V8 4.5L Turbo 9/2002 >



Core Height	287mm	Core Width	292mm
Core Thickness	50mm	Inlet / Outlet	
Oil Cooler			
Condenser		Receiver Drier	

Notes: L/H Fit. Bolt on long pipe. Clip on short pipe

NIS46611CAC

To suit Renault Koleos
9/2008 >



Core Height	654mm	Core Width	157mm
Core Thickness	64mm	Inlet / Outlet	
Oil Cooler			
Condenser		Receiver Drier	

Notes:

SCA24331CAC

To suit Scania 3 Series R112, R124
8.5, 11 & 14.2L 1988 - 1996



Core Height	672mm	Core Width	650mm
Core Thickness	52mm	Inlet / Outlet	
Oil Cooler			
Condenser		Receiver Drier	

Notes:

SCA24041CAC

To suit Scania 4 Series

10.6, 11.7, 14.2 & 15.6L 11/1995 >



Core Height	788mm	Core Width	825mm
Core Thickness	66mm	Inlet / Outlet	81 / 81
Oil Cooler			
Condenser		Receiver Drier	

Notes:

VW46151CAC

To suit Skoda Octavia

4 cyl 1.9L Turbo Diesel 10/2007 >



Core Height	617mm	Core Width	407mm
Core Thickness	32mm	Inlet / Outlet	
Oil Cooler			
Condenser		Receiver Drier	

Notes:

VW23541CAC

To suit Skoda Superb

1.8 & 2.0L Turbo Diesel & Petrol 2009 >



Core Height	617mm	Core Width	406mm
Core Thickness	32mm	Inlet / Outlet	
Oil Cooler			
Condenser		Receiver Drier	

Notes:

VW46161CAC

To suit Volkswagen EOS

4 cyl 1.9L Turbo Diesel 8/2004 >



Core Height	617mm	Core Width	407mm
Core Thickness	32mm	Inlet / Outlet	
Oil Cooler			
Condenser		Receiver Drier	

Notes:

VW23541CAC

To suit Volkswagen EOS Golf V

Turbo Petrol 2003 >



Core Height	617mm	Core Width	406mm
Core Thickness	32mm	Inlet / Outlet	
Oil Cooler			
Condenser		Receiver Drier	

Notes:

VW46151CAC

To suit Volkswagen Golf V

4 cyl 1.9 & 2.0L Turbo Diesel 8/2004 - 12/2009



Core Height	617mm	Core Width	407mm
Core Thickness	32mm	Inlet / Outlet	
Oil Cooler			
Condenser		Receiver Drier	

Notes:

VW46141CAC



To suit Volkswagen Polo

4 cyl 1.2 & 1.6L Turbo Diesel 6/2009 >



Core Height	640mm	Core Width	82mm
Core Thickness	64mm	Inlet / Outlet	
Oil Cooler			
Condenser		Receiver Drier	

Notes:

VW46201CAC



To suit Volkswagen Passat

4 cyl 2.0L Turbo Diesel 8/2005 >



Core Height	617mm	Core Width	407mm
Core Thickness	32mm	Inlet / Outlet	
Oil Cooler			
Condenser		Receiver Drier	

Notes:

VW46061CAC



To suit Volkswagen Passat

4 cyl 1.8 & 2.0L Turbo Petrol 5/2008 >



Core Height	617mm	Core Width	407mm
Core Thickness	32mm	Inlet / Outlet	
Oil Cooler			
Condenser		Receiver Drier	

Notes:

VW46201CAC



To suit Volkswagen Tiguan

4 cyl 2.0L Turbo Diesel 5/2008 >



Core Height	617mm	Core Width	407mm
Core Thickness	32mm	Inlet / Outlet	
Oil Cooler			
Condenser		Receiver Drier	

Notes:

VW46061CAC



To suit Volkswagen Tiguan

4 cyl 2.0L Turbo Petrol 5/2008 >



Core Height	617mm	Core Width	407mm
Core Thickness	32mm	Inlet / Outlet	
Oil Cooler			
Condenser		Receiver Drier	

Notes:

VW23471CAC



To suit Volkswagen Touareg

V6 4.5L Turbo Diesel 9/2006 >



Core Height	287mm	Core Width	292mm
Core Thickness	50mm	Inlet / Outlet	
Oil Cooler			
Condenser		Receiver Drier	

Notes: L/H Fit. Bolt on long pipe. Clip on short pipe

VW29571CAC

To suit Volkswagen Touareg
V6 3.0L Turbo Diesel 3/2006 >



Core Height	287mm	Core Width	292mm
Core Thickness	50mm	Inlet / Outlet	
Oil Cooler			
Condenser		Receiver Drier	

Notes: R/H Fit. Clip on fittings both pipes

VW23511CAC

To suit Volkswagen Transporter Multivan
5 cyl 2.5L Turbo Diesel 9/2004 >



Core Height	720mm	Core Width	194mm
Core Thickness	32mm	Inlet / Outlet	
Oil Cooler			
Condenser		Receiver Drier	

Notes:

VOL77071CAC

To suit Volvo FH12 FH16
12.1 & 16.1L 8/1993 >



Core Height	885mm	Core Width	915mm
Core Thickness	62mm	Inlet / Outlet	
Oil Cooler			
Condenser		Receiver Drier	

Notes:

VOL27551CAC

To suit Volvo FH12
12.1L 1993 >



Core Height	889mm	Core Width	752mm
Core Thickness	62mm	Inlet / Outlet	
Oil Cooler			
Condenser		Receiver Drier	

Notes:

VOL24341CAC

To suit Volvo NL10 NL12 Truck



Core Height	633mm	Core Width	880mm
Core Thickness	51mm	Inlet / Outlet	77 / 77
Oil Cooler			
Condenser		Receiver Drier	

Notes:

VOL29541CAC

To suit Volvo C30 C70 SII S40 SII V50
2.5L 4/2004 >

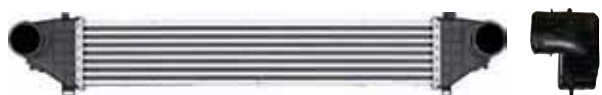

Core Height	650mm	Core Width	113mm
Core Thickness	50mm	Inlet / Outlet	
Oil Cooler			
Condenser		Receiver Drier	

Notes:

Radiator Caps

Radiator Caps

RAD/CAP

Radiator Cap Short Reach
90Kpa (13Psi)



RAD/CAP2230

Radiator Cap Short Reach
110Kpa (16Psi)



RAD/CAPLGE

Radiator Cap Large
90Kpa (13Psi) Standard Automotive Application



RAD/CAPSM

Radiator Cap Small
90Kpa (13Psi) Popular Japanese Application



OEX[®]

Testing for stray current has never been easier.

Introducing the OEX Stray Current Tester

Stray current can be extremely damaging to automotive cooling systems if left undiagnosed. In severe cases, stray current can cause extreme aluminium corrosion resulting in damage to radiators, water pumps and even engine blocks. Extensive damage can occur within weeks.

The OEX Stray Current Tester is specifically designed to accurately detect electrical current within vehicle cooling systems.

Stray Current, commonly referred to as Electrolysis, is the premature deterioration of cooling system components caused by electrical current passing through the cooling system.

Electrolysis usually attacks the inner lining of radiator tubes. The tube material is systematically corroded due to improper grounding of the electrical components. Electrical grounding problems can be caused from poor installation of aftermarket accessories or incorrect installation of components after smash repairs.

Examples of damage caused by Stray Current:

1. Corrosion of tubes typically resulting in multiple holes
2. Build up of aluminium oxide blocking passages
3. White aluminium oxide powder visible through the inlet and outlet tubes.

Thanks to the advanced design and features of the OEX Stray Current Tester, checking for stray current has never been so easy. Please contact your Ashdown-Ingram representative for more information, or to order your Stray Current Tester today.

www.quantumpro.com.au

Part No. ACX100



THE SPECIALIST'S CHOICE

Keep your cool

The OEX Auto Electrical and Thermal Control Components range integrates the latest technologies, innovations and quality control checks to ensure delivery of market leading products.

Every time.

For further information contact Ashdown-Ingram
www.quantumpro.com.au



OEX[®]

HIGH QUALITY VEHICLE COMPONENTS

Air Conditioning & Engine Cooling...Redefined!

Condensers | Compressors | Driers | Radiators | Intercoolers | Fans | Visco Clutches | Blades and more...

Behr Hella Service - Your complete cooling solution.

- Complete cooling solutions for passenger and commercial vehicles
- 1,000+ Australian applications
- Covering engine cooling and air conditioning
- Global supplier to OEM's
- 100+ years experience in engine cooling
- Online catalogue



S E R V I C E

Industrial Radiator Cores

PART NO.	CROSS REFERENCE	DESCRIPTION	CORE HEIGHT	CORE WIDTH	CORE THICKNESS	CORE TYPE	FPI	TOP HEADER PLATE	BOTTOM HEADER PLATE	HEADER PLATE TYPE	GASKET SET
AIR											
AR01	Use PK02	Genset	533	492	60	5/8"	9	559 x 140	559 x 140	Bolt On	POA
AR02	SP1384	Genset	610	587	60	5/8"	9	644 x 178	644 x 178	Bolt On	SV01GK
AR03	Use CU11	Genset	647	667	73	5/8"	9	730 x 140	730 x 140	Bolt On	POA
AR04	CAF2015	Genset Intercooler (HT solder)	1067	1049	95	INL	6.5	1118 x 220	1118 x 220	Bolt On	POA
AR05	MLF1823	Genset	809	826	87	5/8"	11	882 x 160	882 x 160	Bolt On	POA
AR06	MLF1865	Genset	889	587	87	5/8"	11	644 x 178	644 x 178	Bolt On	SV01GK
AR07	CAF1864	Genset Intercooler (HT solder)	889	594	95	INL	9	644 x 178	644 x 178	Bolt On	SV01GK
AR08	SP-1390	W Size 10	889	841	73	5/8"	9	902 x 178	902 x 178	Bolt On	AR08GK
AR09	SP-644 / 5ML9	Size 16 B	1230	1235	87	5/8"	9	1319 x 178	1319 x 178	Bolt On	POA
AR10	SP-96 / 3ML9	Size 14 B	1137	1111	60	5/8"	9	1190 x 178	1190 x 178	Bolt On	POA
AR11	SP-102 / 4MLF9	Size 15 B	1181	1159	73	5/8"	9	1233 x 178	1233 x 178	Bolt On	POA
ALLIS CHALMERS											
AL01	ALC223	Dozer	584	635	101	5/8"	6.5	654 x 133	654 x 121	Flanged	
AL02	ALC210	D 12	368	381	60	5/8"	9	381 x 111	381 x 64	Flanged	
AL03	ALC213	Dozer / Grader	610	540	73	5/8"	6.5	540 x 143	540 x 84	Flanged	
AL04	ALC227	Dozer	908	953	101	5/8"	6.5	1024 x 184	1024 x 184	Bolt On	POA
AL05	ALC750	Gleaner Harvester	1065	742	95	INL	5.5	758 x 124	758 x 124	Flanged	
AL06	ALC445	Gleaner Header	700	620	134	INL	9	630 x 160	630 x 160	Flanged	
ALFA											
AF01	ALF804	Berlina	321	457	46	1/2"	11	460 x 70	460 x 51	Flanged	
ATKINSON											
AK01	ATK805 / MLF1027	Atkinson Cabover Mark III	997	762	101	1/2"	9	816 x 186	816 x 186	Bolt On	KW01GK
ATLAS COPCO											
AT01	Atlas Copco	Dump truck	1367	1365		mix	11	1438 x 234	1438 x 234	Bolt On	AT01GK
AT02	N/A	Jumbo (Deutz Engine)	650	419	128	1/2"	6.5	418 x 145	418 x 145	Flanged	
AT03	N/A	Coaltram	965	524	87	5/8"	11	550 x 155	550 x 155	Flanged	
AUSTIN											
AU01	AUS214	Healey	340	476	73	5/8"	9	492 x 122	492 x 83	Flanged	
AU02	AUS839	Truck	473	572	60	5/8"	13	584 x 64	584 x 64	Flanged	
AU03	AUS228	Healey	429	381	60	5/8"	9	406 x 117	406 x 73	Flanged	
AUX											
AX01	AUX702	Genset / Irrigation Pump	155	191	134	INL	9	196 x 170	238 x 178	Flanged & Bolt on	POA
AVANTI											
CTVN01	AVN901 / CTVN01	Trencher	300	380	57	CT	13	390 x 65	390 x 65	Flanged	
A E V											
AV01	AEV801	Lighting Plant	375	420	32	1/2"	11	426 x 47	426 x 47	Flanged	
BCI COACH											
BC01	N/A	BCI Coach	930	724	73	1/2"	11	735 x 83	735 x 83	Flanged	
CTBC03	N/A	BCI Coach	936	732	57	CT	14	735 x 83	735 x 83	Flanged	

Industrial Radiator Cores

PART NO.	CROSS REFERENCE	DESCRIPTION	CORE HEIGHT	CORE WIDTH	CORE THICKNESS	CORE TYPE	FPI	TOP HEADER PLATE	BOTTOM HEADER PLATE	HEADER PLATE TYPE	GASKET SET
BEARWARD											
BE01	N/A	Genset	1075	925	73	1/2"	9	985 x 150	985 x 150	Bolt on	POA
BE02	N/A	AWB stacker	700	647	76	INL	6.5	730 x 130	730 x 130	Bolt on	POA
CTBE03	N/A	Genset	585	570	38	CT	12	627 x 128	627 x 128	Bolt on	POA
BEDFORD											
BD01	BED23 / 290	SA to SL Truck & Bus	635	651	46	5/8"	13	650 x 95	650 x 64	Flanged	
BD02	BED238	VAM 70	568	683	73	5/8"	11	695 x 83	695 x 83	Flanged	
BD03	BED849	Detroit diesel conversion	602	686	73	1/2"	11	695 x 84	695 x 84	Flanged	
BD04	BED867	Bedford Isuzu	593	635	101	1/2"	11	645 x 150	645 x 150	Flanged	
BD05	BED841	J5L	425	686	60	5/8"	11	695 x 83	695 x 83	Flanged	
BD06	BED235	TK	494	683	73	5/8"	9	695 x 84	695 x 84	Flanged	
CTBD26	BED926 / CTBD01	TJ214 / 220	425	600	38	CT	12	600 x 84	600 x 64	Flanged	
BD07	BED275	Truck	533	635	46	5/8"	11	644 x 90	644 x 64	Flanged	
BD08	BED884	KM 381 to 466	562	683	60	5/8"	9	705 x 81	705 x 81	Flanged	
BD09	BED34 / 275	KM	533	648	38	CT	14	644 x 90	644 x 64	Flanged	
BD10	BED269 OEX	SS / SL Truck & Bus	637	651	60	5/8"	11	659 x 70	659 x 70	Flanged	
BUCYRUS											
BY01	N/A	FBL-10 Loader	1268	492	115	5/8"	11	520 x 124	520 x 124	Flanged	
BUICK											
BU01	BUI37 OEX	1936 Buick V8	559	457	73	5/8"	9	457 x 76	457 x 76	Flanged	
CTBU02	BUI957	Sedan	445	635	38	CT	13	648 x 72	648 x 72	Flanged	
CASE											
CS01	CAS230	Backhoe 225 / 541 harvester	450	464	60	5/8"	9	467 x 127	467 x 70	Flanged	
CS02	CAS766	Case IH 2388 Header (Brass fin)	935	825	115	INL	5.5	855 x 150	855 x 150	Flanged	
CS03	CAS767	Case IH 2366 Header (Brass fin)	932	780	134	INL	5.5	798 x 152	798 x 152	Flanged	
CS04	CAS232	1070 Tractor	604	570	87	5/8"	9	587 x 96	587 x 96	Flanged	
CS05	CAS516	750 Tractor / D1000	611	635	115	5/8"	6.5	640 x 132	705 x 182	Flanged & Bolt On	POA
CS06	CAS258	Backhoe	688	700	101	5/8"	9	718 x 108	718 x 108	Flanged	
CS07	CAS260A	Backhoe (core is cental)	492	523	60	5/8"	9	530 x 120	530 x 120	Flanged	
CS08	N/A	2166 Harvester (Brass fin)	825	780	134	INL	5.5	800 x 150	800 x 150	Flanged	
CS09	CAS201	W 11 Loader (Central) (See also CS27)	492	508	60	5/8"	9	530 x 120	530 x 120	Flanged	
CS10	CAS259	4210 Tractor	488	445	73	5/8"	9	460 x 100	460 x 100	Flanged	
CS11	CAS231NPN	930 Tractor (check dims)	562	460	73	5/8"	9	475 x 82	475 x 82	Flanged	
CS12	CAS234	350 Tractor	384	460	73	5/8"	9	476 x 102	476 x 102	Flanged	
CS13	CAS436	1150B Dozer	699	667	115	5/8"	6.5	710 x 178	710 x 178	Bolt On	POA
CS14	CAS263	450B Dozer	492	524	101	5/8"	9	530 x 120	530 x 120	Flanged	
CS15	CAS414	800 / 800C	508	635	87	5/8"	6.5	686 x 162	686 x 162	Bolt On	POA
CS16	CAS222	830 Tractor	546	460	73	5/8"	9	475 x 83	475 x 83	Flanged	
CS17	CAS260B	1835 / 1845 (core is flush front)(Brass fin)	492	523	60	5/8"	9	530 x 120	530 x 120	Flanged	
CS18	CAS255	2188	467	455	60	5/8"	9	453 x 64	453 x 64	Flanged	
CS19	CAS238	Bobcat (flush front)	502	476	60	5/8"	6.5	500 x 97	500 x 97	Flanged	

PART NO.	CROSS REFERENCE	DESCRIPTION	CORE HEIGHT	CORE WIDTH	CORE THICK-NESS	CORE TYPE	FPI	TOP HEADER PLATE	BOTTOM HEADER PLATE	HEADER PLATE TYPE	GASKET SET
CASE (continued)											
CS20	CAS220B	930B loader (5mm oh) (brass fin)	543	667	73	5/8"	9	691 x 103	691 x 103	Flanged	
CS21	CAS235	Tractor	395	445	46	5/8"	6.5	453 x 63	453 x 63	Flanged	
CS22	CAS752 (16S)	Loader 621 / 2590 / 2390	665	699	101	5/8"	9	720 x 120	720 x 120	Flanged	
CS23	CAS233	1070 / 1270 / 1370	600	572	60	5/8"	9	582 x 92	582 x 92	Flanged	
CS24	CAS218	Crawler	413	460	73	5/8"	9	476 x 102	476 x 102	Flanged	
CS25	CAS205	L & SE Model	581	476	73	5/8"	6.5	565 x 159	565 x 159	Bolt On	POA
CS26	CAS256	Tractor 2670	678	762	101	5/8"	9	790 x 110	790 x 110	Flanged	
CS27	CAS201	W 11 Loader (10mm oh) (see also CS09)	492	508	60	5/8"	9	530 x 120	530 x 120	Flanged	
CS28	CAS227	Dozer 850B	637	555	101	5/8"	9	637 x 185	637 x 185	Bolt On	POA
CATERPILLAR & ELPHINSTONE											
CA01	CAT6122B / 6N7661	992C Wheel Loader	1490	1445	152	Cant	9	1524 x 241	1524 x 241	Bolt On	POA
CTCA01	CAT9235	Excavator	882	825	57	CT	13	835 x 85	835 x 85	Flanged	
CA02	CAT616B	16G Grader	858	848	96	Cant	9	904 x 108	904 x 108	Flanged	
CA03	CAT688B / 8N7859	920 Loader (25x38 deep notch)	718	746	57	Cant	9	830 x 140	746 x 140	Bolt On	POA
CA04	CAT6143 / 4N8190	3304 / 3306 / 3412 Generator	965	921	96	Cant	9	1003 x 267	1003 x 205	Bolt On	POA
CA05	CAT6148B / 2P6830	980C Loader	952	955	115	Cant	9	1020 x 205	1020 x 205	Bolt On	POA
CA06	N/A	637G Scraper (rear)	1017	594	115	INL	11	597 x 154	597 x 154	Flanged	
CA07	CAT6621 / 5S0602	621 Scraper	991	747	152	Cant	9	810 x 204	810 x 204	Bolt On	POA
CA08	CAT6163B / 8N66	773B Dump Truck	1374	1286	152	Cant	9	1360 x 243	1360 x 243	Bolt On	POA
CA09	CAT6235 / 7S2244	950 / 966 Wheel Loader	775	667	115	Cant	9	705 x 166	705 x 166	Bolt On	POA
CA10	CAT6277 / 6N9785	824 / 825 / 826 Compactor	1141	985	152	Cant	9	1053 x 225	1053 x 225	Bolt On	POA
CA11	CAT6153B / 4N8559	3408 / 3412 Genset	1143	1223	115	Cant	9	1270 x 330	1270 x 230	Bolt On	POA
CA12	CAT6271B / 8N5382	816B Compactor	1087	1032	115	Cant	9	1106 x 230	1106 x 230	Bolt On	POA
CA13	CAT6300B	Forklift V300	615	590	96	Cant	13	610 x 110	610 x 110	Flanged	
CA14	CAT6121B / 6N0973	D9H / D9PS (CTR BARS)	1302	1175	152	Cant	9	1245 x 208	1245 x 208	Bolt On	POA
CA15	CAT6355B / MDF1676	AD55 Dump Truck	1228	778	100	5/8"	9	859 x 178	859 x 178	Bolt On	CA15GK
CA16	CAT6166B / 8N4880	3406 Genset	1143	1223	96	Cant	9	1270 x 330	1270 x 230	Bolt On	POA
CA17	N/A	Traxcavator	742	420	134	Cant	6.5	425 x 166	425 x 166	Flanged	
CA18	CAT6253B / 7N4384	D6C	883	794	76	Cant	9	838 x 168	838 x 168	Bolt On	POA
CA20	CAT6280B / 6N9786	980C Loader	1150	1111	95	Cant	9	1187 x 228	1187 x 228	Bolt On	POA
CA21	CAT6286B / 7N9314	631 scraper	1228	1207	134	Cant	9	1270 x 225	1270 x 225	Bolt On	POA
CA22	CAT6140B / 4N7279	D7G (Ctr Bars & Notched)	1104	1000	115	Cant	9	1118 x 200	1042 x 200	Bolt On	POA
CA23	CAT4110B / 8N4077	930 Loader / D3 Dozer	552	540	96	Cant	9	561 x 122	561 x 122	Flanged	

Industrial Radiator Cores

PART NO.	CROSS REFERENCE	DESCRIPTION	CORE HEIGHT	CORE WIDTH	CORE THICKNESS	CORE TYPE	FPI	TOP HEADER PLATE	BOTTOM HEADER PLATE	HEADER PLATE TYPE	GASKET SET
CATERPILLAR & ELPHINSTONE (continued)											
CA24	CAT6254B / 7N3542	D6C	883	794	115	Cant	9	838 x 168	838 x 168	Bolt On	POA
CA25	CAT6279B / 6N0880	D8K (CTR BARS)	1156	1145	115	Cant	9	1185 x 203	1185 x 203	Bolt On	POA
CA26	CAT6164B / 4N6298	D6C / D6D	882	667	115	Cant	6.5	709 x 167	709 x 167	Bolt On	POA
CA27	CAT6182B / ML-1618	Genset	667	699	60	5/8"	9	718 x 108	718 x 108	Flanged	
CA28	CAT670B / 8S2645	D8H (CTR BARS)	1156	1080	115	Cant	9	1155 x 167	1155 x 167	Bolt On	POA
CA29	CAT6224B / 5S4592	D4	660	714	76	Cant	6.5	747 x 147	734 x 127	Bolt On	POA
CA30	CAT225B	225 Excavator	640	683	73	5/8"	9	685 x 100	685 x 100	Flanged	
CA31	CAT687B / 4N8248	14 Grader	718	746	76	Cant	9	830 x 140	746 x 140	Bolt On	POA
CA32	CAT6963 / 1W1502	963 Loader	1055	541	133	Cant	9	593 x 250	593 x 250	Bolt On	POA
CA33	8N184	943 Loader	740	429	96	Cant	9	421 x 166	421 x 166	Bolt On	POA
CA34	N/A	RM 350	1063	1028	115	Cant	11	1105 x 327	1105 x 327	Bolt On	POA
CA35	N/A	375 Excavator	1198	1251	115	INL	9	1355 x 220	1355 x 220	Bolt On	POA
CA36	Use CA30	225 Excavator	640	683	73	5/8"	9	685 x 100	685 x 100	Flanged	
CA37	CAT554B / 1S1386	D2	575	572	76	Cant	6.5	641 x 136	641 x 136	Bolt On	POA
CA38	CAT6130B / 8S7794	14G Grader	752	826	57	Cant	9	925 x 140	845 x 140	Bolt On	POA
CA39	CAT6126B / 1P4404	966 / 966C	965	794	95	Cant	9	834 x 214	834 x 214	Bolt On	POA
CA40	CAT4131B /	14G Grader	848	857	76	Cant	9	903 x 102	903 x 102	Flanged	
CA41	CAT6162 / 1P1683	977L Loader	1026	651	152	Cant	9	686 x 212	716 x 212	Bolt On	POA
CA42	CAT6259B / 4N8191	3306 to 3412 Genset	965	921	115	Cant	9	1000 x 270	1000 x 205	Bolt On	POA
CA43	CAT2169 / 2N254	3306 Genset	833	730	73	5/8"	9	752 x 190	752 x 130	Bolt On	POA
CA44	CAT6216B / 9B1194	D2 Dozer	559	572	73	Cant	9	580 x 123	580 x 123	Bolt On	POA
CA45	CAT6154B / 1W1895	950B Loader	975	778	115	Cant	9	850 x 230	850 x 230	Bolt On	POA
CA46	CAT6258B / 5S5991	955 / 955K Loader	959	699	115	Cant	9	748 x 188	748 x 188	Bolt On	POA
CA47	CAT669B OEX / 9M6600	D4 Dozer	533	540	76	Cant	6.5	588 x 143	588 x 143	Bolt On	POA
CA48	CAT6773B / 1S629	773B Dump Truck	1373	1239	152	Cant	9	1295 x 244	1295 x 244	Bolt On	POA
CA49	CAT532B	D2 / Grader	575	460	76	Cant	6.5	645 x 135	645 x 135	Bolt On	CA49GK
CA50	CAT6270B / 1N3219	966D Loader	1090	889	95	Cant	9	955 x 228	955 x 228	Bolt On	POA
CA51	CAT6132B variant	D6DD	813	889	115	Cant	9	923 x 171	923 x 171	Bolt On	POA
CA52	N/A	950G Loader	852	583	115	INL	9	595 x 147	594 x 147	Flanged	
CA53	CAT628B / 6H9008	D6 Dozer	680	603	115	Cant	6.5	838 x 216	614 x 170	Bolt On	POA
CA54	CAT6150B	Loader	1226	1207	152	Cant	9	1264 x 225	1264 x 225	Bolt On	POA
CA55	CAT4160B	Genset	833	730	115	Cant	9	752 x 190	752 x 130	Flanged	
CA56	CAT6248B	D5 Dozer (Notched)	857	699	95	Cant	9	747 x 147	747 x 147	Bolt On	POA
CA57	CAT6135 / 7N2191	D9L	1375	1286	134	Cant	9	1360 x 243	1360 x 243	Bolt On	POA

PART NO.	CROSS REFERENCE	DESCRIPTION	CORE HEIGHT	CORE WIDTH	CORE THICKNESS	CORE TYPE	FPI	TOP HEADER PLATE	BOTTOM HEADER PLATE	HEADER PLATE TYPE	GASKET SET
CATERPILLAR & ELPHINSTONE (continued)											
CA58	N/A	Energy Power Systems (4 Section)	1170	1048	115	5/8"	9	1156 x 190	1156 x 190	Bolt On	POA
CA59	N/A	D4	535	530	76	INL	6.5	711 x 136	711 x 136	Bolt On	POA
CA60	N/A	3512 Cooling Pack	1267	978	115	1/2"	9	1035 x 254	1035 x 254	Bolt On	POA
CA61	N/A	3512 Cooling Pack	1267	1575	115	1/2"	9	1638 x 254	1638 x 254	Bolt On	POA
CA62	CAT6157B	639 / 639D Scraper	1016	953	152	Cant	9	1016 x 203	1016 x 203	Bolt On	POA
CA63	CAT6287B	769 Drump Truck	1226	1207	115	Cant	9	1264 x 225	1264 x 225	Bolt On	POA
CA64	CAT6128 (Steel fin)	657B Scraper	1320	1286	115	Cant	9	1381 x 203	1381 x 203	Bolt On	POA
CA65	N/A	CAT657B Scraper	1201	742	152	INL	9	740 x 206	740 x 206	Bolt On	POA
CA66	N/A	Genset	1220	1635	73	5/8"	11	1700 x 230	1700 x 230	Bolt On	POA
CA67	N/A	Genset	825	1302	73	5/8"	9	1360 x 180	1360 x 180	Bolt On	POA
CA68	CAT6161B	Genset	1295	1223	95	Cant	9	1270 x 330	1270 x 230	Bolt On	POA
CA69	CAT6301B	Loader	610	635	115	Cant	9	645 x 160	645 x 160	Bolt On	POA
CA70	N/A	350 kVa Genset	1145	1029	60	1/2"	11	1092 x 180	1092 x 180	Bolt On	POA
CA71	N/A	740 Dump Truck	1003	857	115	Cant	9	910 x 175	910 x 175	Bolt On	POA
LP01	ELP818B	R2900 JLK	1520	953	115	5/8"	9	1030 x 216	1030 x 216	Bolt On	LP01GK
LP02	ELP808B / MDF1643	R1700G	1230	651	101	5/8"	9	730 x 178	730 x 178	Bolt On	LP02GK
LP03	ELP617B	R2900 GLK (Upgrade)	1230	953	128	5/8"	9	1028 x 216	1028 x 216	Bolt On	POA
LP04	ELP616B / MDF1703	R1300	871	841	87	5/8"	9	900 x 178	900 x 178	Bolt On	LP04GK
LP05	ELP723B	R1700	1218	710	115	INL	9	772 x 178	772 x 178	Bolt On	LP09GK
LP06	CAF1878 / NPN0821	Elphinstone Intercooler (HT Solder) / AD45B	1231	530	134	INL	9	600 x 192	600 x 192	Bolt On	POA
CA15	CAT6355B / MDF1676	AD55 Dump Truck	1228	778	100	5/8"	9	859 x 178	859 x 178	Bolt On	POA
LP08	ELP827B	R2900	1230	953	140	5/8"	9	1030 x 216	1030 x 216	Bolt On	LP01GK
LP09	ELP623B	R1700 SBR Loader	1218	714	101	5/8"	9	772 x 178	772 x 178	Bolt On	LP09GK
LP10	NPN0814 / CAF1646	R1600G / R2900 early Intercooler (HT Solder)	1068	355	95	INL	6.5	430 x 178	430 x 178	Bolt On	LP12GK
LP11	N/A	R1300 (Early)	1035	587	101	5/8"	9	644 x 178	644 x 178	Bolt On	POA
LP12	NPN0812 / CAF1645	R1700G / R2900G / GLK (HT Solder)	1168	371	95	INL	6.5	430 x 178	430 x 178	Bolt On	LP12GK
LP13	NPN0826 / SYS-CAF1889	R2900 JLK (HT Solder)	1468	360	134	INL	6.5	430 x 216	430 x 216	Bolt On	LP13GK
LP14	NPN0828	AD55B (HT Solder)	1187	530	152	INL	6.5	600 x 242	600 x 242	Bolt On	LP14GK
LP15	MLF1991 / NPN0827	AD55B	1232	810	101	5/8"	9	900 x 215	900 x 215	Bolt On	POA
LP16	ELP815B / MDF1644	R1600	1130	667	87	5/8"	9	730 x 178	730 x 178	Bolt On	LP02GK
LP19	ELP609B	5TW R2900	1230	826	101	5/8"	9	900 x 178	900 x 178	Bolt On	LP04GK
LP20	ELP610B / MDF1707	Ejector Truck	1218	1222	115	5/8"	9	1288 x 178	1288 x 178	Bolt On	POA
LP22	ELP622B / MLF1879	AD45B Dump Truck	1230	730	101	5/8"	9	816 x 178	816 x 178	Bolt On	POA
CBM											
CB01	N/A	CBM 965x965 core	965	965	73	1/2"	9	1030 x 180	1030 x 180	Bolt On	POA
CB02	N/A	Lincoln 4 Section	968	914	115	1/2"	9	990 x 220	990 x 220	Bolt On	POA
CB03	CBM1707	Cummins core	711	660	46	1/2"	11	730 x 180	730 x 180	Bolt On	POA
CB04	CBM1708	Cummins core	547	470	46	1/2"	11	535 x 150	535 x 150	Bolt On	POA
CB05	N/A	4 Section	916	813	73	1/2"	11	890 x 180	890 x 180	Bolt On	POA

Industrial Radiator Cores

PART NO.	CROSS REFERENCE	DESCRIPTION	CORE HEIGHT	CORE WIDTH	CORE THICKNESS	CORE TYPE	FPI	TOP HEADER PLATE	BOTTOM HEADER PLATE	HEADER PLATE TYPE	GASKET SET
CBM (continued)											
CB06	N/A	4 Section	920	1041	101	1/2"	9	1118 x 220	1118 x 220	Bolt On	POA
CB07	CBM1701	Cummins 6CTA	800	749	60	1/2"	11	826 x 180	826 x 180	Bolt On	POA
CB08	CBM1714	Cummins M11	965	965	60	1/2"	9	1030 x 180	1030 x 180	Bolt On	POA
CB09	CBM1704 / CBM1730	Cummins 4BTA	610	584	46	1/2"	11	656 x 180	656 x 180	Bolt On	POA
CB10	CBM1716	Cummins N14	965	1054	60	1/2"	11	1118 x 180	1118 x 180	Bolt On	POA
CB11	N/A	4 Section	914	1054	73	1/2"	9	1118 x 220	1118 x 220	Bolt On	POA
CB12	CBM1710	Cummins QSC15	1067	1054	60	1/2"	9	1118 x 180	1118 x 180	Bolt On	POA
CB13	N/A	Genset	1223	1118	60	1/2"	13	1195 x 180	1195 x 180	Bolt On	POA
CB14	4042-115	Compression Station	1370	965	60	1/2"	9	1046 x 180	1046 x 180	Bolt On	POA
CB15	CBM1730	Cummins 6BTWM (use CB09)	610	584	46	1/2"	9	656 x 180	656 x 180	Bolt On	POA
CB16	3898-001	Genset OE No. CSP00549	997	810	101	5/8"	11	890 x 220	890 x 220	Bolt On	POA
CB17	N/A	Caterpillar Genset	798	813	60	1/2"	11	890 x 180	890 x 180	Bolt On	POA
CB18CAC	N/A	Caterpillar Genset CAC	800	820	99	CAC	5.5	890 x 180	890 x 180	Bolt On	POA
CB19	N/A	Cummins Power Pack	800	1600	95	INL	9	1675 x 220	1675 x 220	Bolt On	POA
CB20	N/A	Sykes Pump	816	660	73	1/2"	9	730 x 180	730 x 180	Bolt On	POA
CB21	CBM3445	Sykes Pump	965	508	73	1/2"	9	584 x 180	584 x 180	Bolt On	POA
CB22CAC	CBM3445	Sykes Pump CAC	965	410	99	CAC	6.5	480 x 180	480 x 180	Bolt On	POA
CB23	N/A	Cummins Power Pack	762	635	73	1/2"	11	710 x 180	710 x 180	Bolt On	POA
CB24	CBM3184	Cummins Power Pack	762	635	73	1/2"	11	710 x 180	710 x 180	Bolt On	POA
CB25	N/A	Cummins Pump	710	343	60	1/2"	11	405 x 180	405 x 180	Bolt On	POA
CHAMBERLAIN											
CH01	CHA207	Champion tractor	546	508	73	5/8"	9	515 x 84	515 x 84	Flanged	
CH02	CHA208	Champion 236 tractor	511	508	73	5/8"	9	515 x 84	515 x 84	Flanged	
CH03	CHA206	Champion mark 2	489	508	73	5/8"	9	510 x 84	510 x 84	Flanged	
CH04	CHA211	3686 / 3885	690	571	73	5/8"	9	570 x 77	570 x 77	Flanged	
CH05	CHA201	Super	616	619	101	5/8"	9	723 x 165	723 x 165	Bolt On	POA
CH06	CHA202	Champion 6G, 9G	495	508	73	5/8"	9	514 x 158	514 x 83	Flanged	
CH07	CHA210	Australian John Deere Tractor	628	572	73	5/8"	9	570 x 77	570 x 77	Flanged	
CH08	CHA205	Super 90	660	587	73	5/8"	9	586 x 78	586 x 78	Flanged	
CH09	CHA212	4280 / 4685	728	619	73	5/8"	9	623 x 77	623 x 77	Flanged	
CH10	CHA203	Tractor	495	587	73	5/8"	9	586 x 78	586 x 78	Flanged	
CHEVROLET											
CV01	CHE217	Maple Leaf	525	492	73	5/8"	11	498 x 76	498 x 76	Flanged	
CTCV02	CHE912 / CTCV02	C20 Truck	669	430	57	CT	12	475 x 71	475 x 71	Flanged	
CTCV24	CHE920 / CHE924	Sedan	720	430	57	CT	15	475 x 72	475 x 72	Flanged	
CTCV03	CHE908	Impala	432	635	38	CT	14	646 x 64	646 x 64	Flanged	
CLARKE											
CL01	CLA251	753 Bobcat	665	286	73	5/8"	6.5	305 x 108	305 x 108	Flanged	
CL02	CLA438	Omega	800	762	101	5/8"	9	836 x 175	836 x 175	Bolt On	POA
CL03	CLA330	C500 YS60D Forklift	499	445	60	5/8"	9	455 x 86	455 x 86	Flanged	
CL04	CLA245 INL	Bobcat Loader	762	286	95	INL	6.5	305 x 110	305 x 110	Flanged	
CL05	CLA245	Bobcat Loader	762	286	87	5/8"	6.5	305 x 110	305 x 110	Flanged	
CL06	CLA232	Forklift	493	450	60	5/8"	9	450 x 82	450 x 82	Flanged	

PART NO.	CROSS REFERENCE	DESCRIPTION	CORE HEIGHT	CORE WIDTH	CORE THICK-NESS	CORE TYPE	FPI	TOP HEADER PLATE	BOTTOM HEADER PLATE	HEADER PLATE TYPE	GASKET SET
CLARKE (continued)											
CL07	CLA236	Forklift	490	460	73	5/8"	9	458 x 83	458 x 83	Flanged	
CL08	CLA753	753 Bobcat	628	286	95	INL	5.5	303 x 105	303 x 105	Flanged	
CL09	CLA250	Forklift	420	635	101	5/8"	9	655 x 110	655 x 110	Flanged	
CL10	N/A	Omega	848	540	73	5/8"	11	600 x 178	600 x 178	Bolt On	POA
CL11	N/A	Omega 54D	890	841	87	5/8"	11	900 x 178	900 x 178	Bolt On	LP04GK
CLAAS											
CZ01	N/A	Tractor	747	710	95	INL	6.5	715 x 115	715 x 115	Flanged	
CLETRAC											
CE01	N/A	Cleveland Tractor CG & DD	636	603	60	5/8"	6.5	683 x 156	683 x 156	Bolt On	POA
CLEYSON											
CY01	CLY701	Harvester	580	615	95	INL	5.5	617 x 110	617 x 110	Flanged	
CY02	CLY706	TR95 Combine	985	731	133	INL	5.5	750 x 150	750 x 150	Flanged	
COMECO											
CM01	CMO503	Harvester	820	827	134	INL	5.5	915 x 203	915 x 203	Bolt On	POA
CM02	CMO504	Harvester	820	826	152	Cant	5.5	916 x 252	916 x 252	Bolt On	POA
CM03	CMO501	Harvester	818	826	115	Cant	6.5	913 x 203	913 x 203	Bolt On	POA
COMPAIR											
CP01	CPR805	Compact 75	457	445	46	1/2"	13	490 x 105	490 x 105	Bolt On	POA
CP02	CPR810	CV125	640	620	46	1/2"	11	667 x 105	667 x 105	Bolt On	POA
CP03	CPR201	Compressor	641	619	60	5/8"	9	665 x 140	665 x 140	Bolt On	POA
CP04	CPR804	CR100 & CR125	507	546	46	1/2"	13	601 x 105	601 x 105	Bolt On	POA
CP05	CPR202	CR125A	641	619	46	5/8"	11	665 x 140	665 x 140	Bolt On	POA
CROWN FORKLIFT											
CW01	N/A	P Series - Forklift	401	456	95	INL	11	475 x 122	475 x 122	Flanged	
CUMMINS DIESEL											
CU01	CUM322 / ABA1617-3MLF	Stationary generator NT855	914	937	57	5/8"	9	1020 x 178	1020 x 178	Bolt On	POA
CU02	CUM309 / SP1230-4MLF9	Sykes Pump S10	889	841	73	5/8"	9	902 x 140	902 x 140	Bolt On	POA
CU03	CUM323 / ABA1617-5MLF	Stationary generator NT series Cummins	914	937	101	5/8"	9	1020 x 178	1020 x 178	Bolt On	POA
CU04	CUM216 / SP1223	6BT Static generator	560	540	76	5/8"	9	601 x 140	601 x 140	Bolt On	POA
CU05	N/A	Genset various	610	600	46	1/2"	11	640 x 162	640 x 162	Bolt On	POA
CU06	N/A	Power Pack (Brass Fin)	1335	1168	60	1/2"	11	1246 x 180	1246 x 180	Bolt On	POA
CU07	CUM215 (1/2") / SP1213	Genset various	559	546	60	1/2"	9	601 x 140	601 x 140	Bolt On	POA
CU08	CUM826 / SP1214	Genset various	610	584	60	1/2"	9	644 x 140	644 x 140	Bolt On	POA
CU09	N/A	Power Pack (Brass Fin)	1142	1168	60	1/2"	11	1246 x 180	1246 x 180	Bolt On	POA
CU10	VH 1546	Genset (Brass fin)	647	667	73	5/8"	11	730 x 140	730 x 140	Bolt On	POA
CU11	CUM880 / SP1228-4ML9	6CTA	787	746	73	5/8"	9	816 x 140	816 x 140	Bolt On	POA
CU12	CUM814 / SP1213	Genset various	560	540	46	5/8"	9	600 x 140	600 x 140	Bolt On	POA

Industrial Radiator Cores

PART NO.	CROSS REFERENCE	DESCRIPTION	CORE HEIGHT	CORE WIDTH	CORE THICKNESS	CORE TYPE	FPI	TOP HEADER PLATE	BOTTOM HEADER PLATE	HEADER PLATE TYPE	GASKET SET
CUMMINS DIESEL (continued)											
CU13	CUM215 (5/8") / SP1213	Genset various	560	540	60	5/8"	9	600 x 140	600 x 140	Bolt On	POA
CU14	CUM201	Genset various	583	572	60	5/8"	9	569 x 89	569 x 89	Flanged	
CU15	N/A	Jubilee Genset (check thickness)	740	721	57	INL	9	785 x 150	785 x 150	Bolt On	POA
CU16	CUM806	6BTA	710	660	46	1/2"	13	730 x 180	730 x 180	Bolt On	POA
CU17	CUM681	Genset various	935	1064	115	5/8"	9	1116 x 214	1116 x 214	Bolt On	POA
CU18	SP-76 / 3MLF9	AR Pack	959	937	60	1/2"	9	1019 x 178	1019 x 178	Bolt On	POA
CU19	CUM3190EX	6CT Genset	686	667	73	5/8"	9	730 x 140	730 x 140	Bolt On	POA
CU20	CU15 (Heavy duty)	Jubilee Genset (check thickness)	740	721	76	INL	9	785 x 150	785 x 150	Bolt On	POA
CU21	CUM229	300kVA Generator (50mm oh)	1220	1175	73	5/8"	9	1226 x 235	1226 x 235	Bolt On	POA
CU22	N/A	KTA38 Generator	1599	1925	101	1/2"	9	2002 x 190	2002 x 190	Bolt On	POA
CU23	CUM321	KTA38 G1 Generator	781	778	73	5/8"	9	848 x 178	848 x 178	Bolt On	POA
CU24	N/A	300kVA Generator	938	940	73	1/2"	13	994 x 178	994 x 178	Bolt On	POA
CU25	CUM308 (12S)	855 series	953	952	60	1/2"	9	1025 x 190	1025 x 190	Bolt On	POA
CU26	CUM812	6BT / 6BTA	591	556	73	5/8"	9	630 x 154	630 x 154	Flanged	
DAEWOO											
DW01	N/A	Excavator	870	795	95	INL	9	793 x 131	793 x 131	Flanged	
DW02	DAE703	Forklift	375	392	95	INL	9	401 x 119	401 x 119	Flanged	
DW03	N/A	DL400 Loader	1050	876	115	1/2"	6.5	915 x 185	915 x 185	Bolt On	POA
DW04	N/A	Loader	980	714	115	5/8"	9	764 x 185	764 x 185	Bolt On	POA
DAIHATSU											
CTDI44	DAI944 / CTDI44	Delta	400	490	38	CT	12	502 x 56	502 x 48	Flanged	
DI06	DAI806 OEX	Delta DV24 / 26								Flanged	
DATSUN											
CTDS01	DAT924 OEX	240 / 260C	394	559	38	CT	14	565 x 52	565 x 52	Flanged	
CTDS02	DAT989	Ute	330	545	38	CT	14	555 x 68	555 x 62	Flanged	
DAVID BROWN											
DA01	DAV208	Tractor	405	381	57	5/8"	6.5	382 x 78	382 x 78	Flanged	
DA02	DAV205	Tractor	458	445	57	5/8"	6.5	451 x 75	451 x 75	Flanged	
DA03	DAV207	Tractor 30D	464	451	46	5/8"	6.5	455 x 80	455 x 80	Flanged	
DA04	DAV710	Tractor	453	445	57	INL	6.5	452 x 77	452 x 77	Flanged	
DA05	DAV814	1190 Tractor	362	445	46	1/2"	9	452 x 64	452 x 64	Flanged	
DENNING											
DN01	DNG409	Coach GM6V92	951	660	115	1/2"	11	730 x 180	730 x 180	Bolt On	POA
DN02	DNG811	Coach (4 Holes - Brass fin)	950	762	140	5/8"	11	814 x 209	814 x 209	Bolt On	POA
DN03	SP-2027	Coach	890	685	87	5/8"	11	730 x 178	730 x 178	Bolt On	LP02GK
DN04	N/A	Coach	1218	584	73	1/2"	11	644 x 140	644 x 140	Bolt On	POA
DN05	DNG509	Coach	951	667	115	5/8"	11	730 x 178	730 x 178	Bolt On	LP02GK
DN06	DNG504K	Coach GM6V92 & 8V71	785	762	101	5/8"	11	840 x 175	840 x 175	Bolt On	POA
DENNIS											
DS01	DDB901	Dart	760	650	57	CT	14	658 x 84	658 x 84	Flanged	

PART NO.	CROSS REFERENCE	DESCRIPTION	CORE HEIGHT	CORE WIDTH	CORE THICKNESS	CORE TYPE	FPI	TOP HEADER PLATE	BOTTOM HEADER PLATE	HEADER PLATE TYPE	GASKET SET
DETROIT											
DT01	DET302	Generator	1096	1095	87	5/8"	11	1123 x 175	1123 x 175	Bolt On	POA
DODGE											
D001	DOD815	Commando	549	686	73	1/2"	13	695 x 85	695 x 85	Flanged	
DOMINO COACH											
DM01	N/A	Domino Coach	890	683	87	5/8"	11	730 x 180	730 x 180	Bolt On	POA
DM02	DOM311	Fire truck	915	622	73	1/2"	11	687 x 140	687 x 140	Bolt On	NT01GK
DM03	DOM803	Domino Coach	889	667	73	5/8"	11	730 x 178	730 x 178	Bolt On	LP02GK
DM04	DOM802	Domino Coach	889	667	101	5/8"	11	730 x 178	730 x 178	Bolt On	LP02GK
DM05	DOM309 / SBW1631	Domino Tourmaster GM8V92	990	587	114	5/8"	11	644 x 178	644 x 178	Bolt On	SV01GK
DRESSER											
DR01	N/A	Dresser TD20 Dozer	1092	921	152	Cant	9	994 x 229	994 x 229	Bolt On	POA
DR02	DRE531	530 Loader	755	683	101	5/8"	9	730 x 200	730 x 200	Bolt On	POA
DR03	N/A	Dresser TD20 Dozer	1067	921	152	Cant	9	994 x 229	994 x 229	Bolt On	POA
DRILLTECH											
DK01	N/A	Drill Rig	1107	1118	60	1/2"	9	1202 x 141	1202 x 141	Bolt On	POA
DK02	N/A	DK 40K	1235	1232	87	1/2"	9	1295 x 185	1295 x 185	Bolt On	POA
DK03	DRI608	Drill Rig	1499	826	152	Cant	9	900 x 230	900 x 230	Bolt On	POA
DK04	DRI603	Drill Rig	1500	937	152	Cant	9	1012 x 229	1012 x 229	Bolt On	POA
EIMCO											
EM01	EIM604 / MLF1625	130 Mine Tractor (V baffle)	845	810	152	CANT	9	856 x 235	856 x 235	Bolt On	POA
EM01BS	EIM604BS OEX	130 (Solder coated x2)	845	810	152	CANT	9	856 x 235	856 x 235	Bolt On	POA
EM02	EIM705NPN	130 Mine Tractor	846	787	115	INL	9	860 x 217	860 x 217	Bolt On	POA
EM03	EIM704B	130 Mine Tractor (V baffle)	845	815	152	INL	6.5	856 x 235	856 x 235	Bolt On	POA
EM04	EIM810 OEX	ED10 Mine Tractor (offset header)	1168	864	60	1/2"	9	940 x 180	940 x 180	Bolt On	EM04GK
EM05	EIM603B	913 Mine Tractor	736	667	152	CANT	9	741 x 209	741 x 209	Bolt On	POA
EM05BS	EIM603BS OEX	913 (Solder coated x 2)	736	667	152	CANT	9	741 x 209	741 x 209	Bolt On	POA
EM06	EIM617B / MLF1657	913 Mine Tractor	736	667	152	CANT	9	730 x 216	730 x 216	Bolt On	POA
EM07	EIM605B	130 Mine Tractor (V baffle)	846	794	152	CANT	9	859 x 216	859 x 216	Bolt On	POA
EM07BS	EIM605BS OEX	130 (Solder coated x2)	846	794	152	CANT	9	859 x 216	859 x 216	Bolt On	POA
EM08	N/A	130 Miner (5 end Holes V baffle)	846	794	152	CANT	9	859 x 216	859 x 216	Bolt On	POA
EM09	EIM703B	913 Mine Tractor	736	668	152	INL	6.5	741 x 209	741 x 209	Bolt On	POA
EM10	EIM617B / MLF1657	913 Mine Tractor (Solder coated Inline)	736	668	152	INL	6.5	730 x 216	730 x 216	Bolt On	POA
EM11	EIM705B / MLF1609	130 Mine Tractor (V baffle) (solder coated)	846	784	152	INL	6.5	859 x 216	859 x 216	Bolt On	POA
EM12	EIM710B	ED10 Mine Tractor (offset header)	1168	869	57	INL	9	940 x 180	940 x 180	Bolt On	EM04GK
EM13CAC	N/A	Sandvik LS191	1218	223	149	CAC	11	284 x 232	284 x 232	Bolt On	POA
ED10	N/A	Special Build Brass Fin (V baffle / offset header)	1168	864	60	1/2"	9	940 x 180	940 x 180	Bolt On	EM04GK

Industrial Radiator Cores

PART NO.	CROSS REFERENCE	DESCRIPTION	CORE HEIGHT	CORE WIDTH	CORE THICK-NESS	CORE TYPE	FPI	TOP HEADER PLATE	BOTTOM HEADER PLATE	HEADER PLATE TYPE	GASKET SET
EUCLID											
EU01	EUC405	Loader	775	749	87	1/2"	6.5	756 x 121	756 x 121	Bolt On	POA
FERGUSON (MASSEY)											
FE01	FER218	1085 Tractor	468	462	73	5/8"	6.5	467 x 102	467 x 77	Flanged	
FE02	FER224	1100 Tractor	556	460	73	5/8"	6.5	467 x 127	467 x 102	Flanged	
FE03	FER211	165 / 175 Tractor	481	381	60	5/8"	9	396 x 117	396 x 69	Flanged	
FE04	FER226	355 Tractor	372	476	60	5/8"	9	485 x 86	485 x 86	Flanged	
FE05	FER222	1155 Tractor	588	619	101	5/8"	9	620 x 120	620 x 103	Flanged	
FE06	FER231	MF375	497	508	73	5/8"	9	528 x 89	528 x 89	Flanged	
FE07	FER213	1130 Tractor	556	460	73	5/8"	6.5	467 x 127	467 x 83	Flanged	
FE08	FER214	65 & 165 Tractor	486	381	60	5/8"	9	395 x 117	395 x 70	Flanged	
FE09	FER223	1844 Tractor	443	460	60	5/8"	9	470 x 100	470 x 73	Flanged	
FE10	FER221	Tractor	463	381	46	5/8"	6.5	397 x 120	397 x 107	Flanged	
FE11	FER229	362 Tractor	368	472	60	5/8"	6.5	483 x 84	483 x 84	Flanged	
FE12	FER203	FE35 Tractor	432	381	60	5/8"	6.5	Dished	Dished	Flanged	
FE13	N/A	3050 Tractor	472	533	60	1/2"	9	527 x 85	527 x 85	Flanged	
FE14	FER717	Tractor	626	636	95	INL	5.5	652 x 112	652 x 112	Flanged	
FE16	FER216	Tractor	483	460	60	5/8"	9	465 x 127	465 x 64	Flanged	
FE17	FER750	Header	710	784	115	INL	5.5	800 x 125	800 x 125	Flanged	
FIAT											
FT01	FIA244	640DT Alis Tractor	445	460	76	5/8"	6.5	467 x 102	465 x 91	Flanged	
FT02	FIA234	880	587	587	87	5/8"	6.5	665 x 156	665 x 156	Bolt On	POA
FT03	FIA238	Tractor	490	540	73	5/8"	9	545 x 137	545 x 90	Flanged	
FT04	FIA226B	Tractor	466	413	60	5/8"	9	422 x 115	422 x 70	Flanged	
FT05	FIA226NPN	Tractor	464	413	60	5/8"	9	422 x 122	422 x 70	Flanged	
FT06	FIA219	Tractor (Brass FIN)	494	476	60	5/8"	6.5	476 x 140	476 x 76	Flanged	
FT07	FIA265B OEX	Tractor	630	546	73	5/8"	6.5	548 x 89	548 x 89	Flanged	
FT08	FIA239	640 Tractor	500	540	73	5/8"	9	550 x 94	550 x 94	Flanged	
FT09	FIA233NPN	Dozer	764	742	115	INL	5.5	746 x 149	746 x 127	Flanged	
FORD & STERLING											
FD01	FD8339 / SBS-1638	Cargo	687	603	73	5/8"	9	644 x 140	644 x 140	Bolt On	POA
FD02	FD8341	Louisville LTS9000 Plastic tank conversion	951	711	60	1/2"	13	742 x 77	742 x 77	Flanged	
FD03	FD8227 / ML1108	Louisville LNT8000	766	660	60	1/2"	13	682 x 79	682 x 79	Flanged	
FD04	FD8361 (Brass Tank Kit)	HN80 Plastic tank conversion (LF)	950	876	60	1/2"	13	892 x 77	892 x 77	Flanged	
FD04COMP1	FD04COMP1	HN80 Brassy Assy (310mm) Cat & Cummins	950	876	60	1/2"	13	892 x 77	892 x 77	Flanged	
FD04COMP2	FD04COMP2	HN80 Brassy Assy (410mm) DETROIT	950	876	60	1/2"	13	892 x 77	892 x 77	Flanged	
FD05	FD215	Mainline / Custom	495	508	60	5/8"	11	508 x 102	508 x 61	Flanged	
FD06	FD2291	Tractor (flush front)	630	556	73	5/8"	6.5	560 x 100	560 x 100	Flanged	
FD07	FD2211 / VHF1013	LNT9000 - 350HP High flow	963	699	73	5/8"	11	793 x 260	793 x 150	Bolt On	FD07GK
FD08	FD4402	Tractor (flush front)	628	559	73	1/2"	6.5	556 x 109	556 x 109	Flanged	
FD09	FD297	D series	514	635	46	5/8"	9	Shaped	647 x 76	Flanged	
FD10	FD8294x4 / VHF1016	LTL9000 high flow	1097	851	60	1/2"	11	932 x 229	932 x 135	Bolt On	FD10GK

PART NO.	CROSS REFERENCE	DESCRIPTION	CORE HEIGHT	CORE WIDTH	CORE THICKNESS	CORE TYPE	FPI	TOP HEADER PLATE	BOTTOM HEADER PLATE	HEADER PLATE TYPE	GASKET SET
FORD & STERLING (continued)											
FD11	FD8407 / VLF1103	Air Radiators Conversion (LF)	990	660	73	1/2"	13	730 x 140	730 x 140	Bolt On	POA
FD12	FD8345 / VLF1024	LTS Cummins(LF)	963	673	73	1/2"	13	790 x 260	790 x 150	Bolt On	POA
FD13	FD8340 / VLF1015	LTL 350 Cummins(LF)	1097	851	60	1/2"	11	932 x 229	932 x 135	Bolt On	FD10GK
FD14	FD2217	Loisville LNT8000	766	667	46	5/8"	11	682 x 79	682 x 79	Flanged	
FD16	FD8360	L9000	951	711	13	1/2"	13	718 x 71	718 x 71	Flanged	
FD17	FD8325x4	Bronco / F100	700	457	13	1/2"	13	471 x 85	471 x 85	Flanged	
FD20	FD8149x4	Falcon XW / XY	441	610	60	1/2"	13	605 x 71	605 x 71	Flanged	
FD21	FD2432	Tractor 7770 (flush front)	510	508	73	5/8"	9	510 x 102	510 x 102	Flanged	
FD22	FD8330	Cargo 3	686	584	87	1/2"	11	646 x 178	646 x 178	Bolt On	POA
FD23	FD2463	Tractor	685	699	101	5/8"	9	720 x 121	720 x 121	Flanged	
FD24	N/A	Deluxe V8 Sedan	584	397	60	5/8"	11	400 x 205	400 x 77	Flanged	
FD25	FD8296 (Brass Tank Kit)	Louisville L8000	888	668	57	INL	13	676 x 88	676 x 88	Flanged	
	FD25COMP	Louisville L8000 Brass Assy								Flanged	
FD26	FD8303x4	Trader	522	634	60	1/2"	11	645 x 85	645 x 85	Flanged	
FD27	FD4396	7810 Tractor	570	445	73	5/8"	9	462 x 105	462 x 105	Flanged	
FD28	FD8282x5	Cargo	668	635	73	1/2"	9	645 x 86	645 x 86	Flanged	
FD29	FD8358	Cargo Cat 3208	685	587	73	5/8"	11	644 x 140	644 x 140	Bolt On	POA
FD30	N/A	Sedan - V8 (Shaped headers)	568	432	73	1/2"	9	430 x 77	430 x 77	Flanged	
CTFD10	FD92983	Cargo	703	627	57	CT	14	635 x 84	635 x 84	Flanged	
CTFD49	FD9149x3	XY GT Falcon	441	614	57	CT	14	605 x 71	605 x 71	Flanged	
CTFD81	FD981 / CTFD08	D series	518	635	57	CT	12	Shaped	647 x 76	Flanged	
CTFD123	FD9123 OEX	F100 6 cyl								Flanged	
CTFD142	FD9142 / CTFD01	XD / XE Falcon	551	457	38	CT	12	481 x 74	481 x 88	Flanged	
CTFD149	FD9149 / CTFD02	XY GT Falcon	441	614	38	CT	14	605 x 71	605 x 71	Flanged	
CTFD210	FD9210 / CTFD03	F100 / F250	489	670	38	CT	15	685 x 78	685 x 78	Flanged	
CTFD212	FD9212 / CTFD04	Falcon XA-XE V8 (8mm oh)	551	457	57	CT	15	481 x 89	481 x 74	Flanged	
CTFD227	FD9227 / CTFD05	L8000	766	665	57	CT	13	682 x 79	682 x 79	Flanged	
CTFD282	FD9282 / CTFD06	Cargo	668	634	57	CT	12	645 x 86	645 x 86	Flanged	
CTFD283	FD9283 / CTFD07	Cargo	703	627	57	CT	14	635 x 84	635 x 84	Flanged	
CTFD296	FD9296 OEX	F100 / F250	550	498	40	CT	12	525 x 74	525 x 74	Flanged	
FORDSON TRACTOR											
FN01	FSN203	Major	476	425	60	5/8"	9	438 x 75	438 x 75	Flanged	
FN02	FSN213	4000 & 5000	446	432	60	5/8"	9	459 x 92	459 x 72	Flanged	
FN03	FSN216	Tractor 4000	451	445	60	5/8"	9	451 x 103	451 x 76	Flanged	
FN04	FSN215	Tractor 6000 (flush front)	450	462	73	5/8"	9	465 x 103	465 x 103	Flanged	
FN05	FSN206	Mini Diesel Tractor	425	365	60	5/8"	9	356 x 64	413 x 64	Flanged	
FN06	FSN218	3000	406	432	60	5/8"	6.5	459 x 92	459 x 72	Flanged	
FN07	FSN219	3600	407	445	60	5/8"	6.5	459 x 92	459 x 72	Flanged	
FN08	FSN205	Dexter Mini	375	349	60	5/8"	9	356 x 64	413 x 64	Flanged	
FN09	FSN201	Tractor	505	445	101	5/8"	5.5	518 x 156	518 x 156	Bolt On	POA
FN10	FSN225	Tractor (flush front)	451	432	60	5/8"	9	460 x 97	460 x 75	Flanged	
FN11	FSN226	770 (flush front)	508	508	73	5/8"	9	508 x 103	508 x 103	Flanged	
FN12	FSN230	4600	610	508	73	5/8"	9	508 x 82	508 x 82	Flanged	
FN13	FSN207	5000	451	445	60	5/8"	6.5	459 x 92	451 x 76	Flanged	
FN14	FSN781	7810	570	445	76	INL	9	462 x 105	462 x 105	Flanged	

Industrial Radiator Cores

PART NO.	CROSS REFERENCE	DESCRIPTION	CORE HEIGHT	CORE WIDTH	CORE THICKNESS	CORE TYPE	FPI	TOP HEADER PLATE	BOTTOM HEADER PLATE	HEADER PLATE TYPE	GASKET SET
FORDSON TRACTOR (continued)											
FN15	FSN210	4000	406	445	60	5/8"	9	451 x 103	451 x 76	Flanged	
FN16	FSN211	3000	406	445	60	5/8"	6.5	459 x 92	459 x 74	Flanged	
FN17	FSN217	5000 / 7000	450	460	73	5/8"	9	465 x 103	465 x 77	Flanged	
FN19	FSN2291 (5 row)	8700 Tractor (Use FD06)	630	556	73	5/8"	6.5	560 x 102	560 x 102	Flanged	
FN20	FSN212	4000	406	445	60	5/8"	9	445 x 103	445 x 76	Flanged	
FRANNA											
FA01	FRA807N	Crane	964	635	60	1/2"	11	730 x 178	730 x 178	Bolt On	LP02GK
FA02	FRA801	MAC14 Crane	626	648	73	1/2"	13	648 x 95	648 x 95	Flanged	
FA03	FRA804 / ML1608	AT14 Crane	676	635	87	5/8"	11	655 x 88	655 x 88	Flanged	
FA04	FRA8200EX / MLF1666	Mobile Crane	757	651	73	5/8"	11	730 x 148	730 x 148	Bolt On	POA
FA05	FRA802 / ML1386	MAC14 Crane	626	645	87	5/8"	13	655 x 90	655 x 90	Flanged	
CTFA06	FRA901 / CTFA06	Mobile Crane (Hino)	626	645	76	CT	14	655 x 90	655 x 90	Flanged	
FA06	FRA805	AT14 Crane	675	651	87	5/8"	11	652 x 92	652 x 92	Flanged	
FREIGHTLINER											
FR01	FRE801 / VHF1517	FL112	938	813	60	1/2"	13	874 x 172	874 x 172	Bolt On	FR01GK
FR02	FRE802 / VHF1074	FL112 Cummins (LF)	938	813	73	1/2"	13	874 x 172	874 x 172	Bolt On	FR01GK
FR02LF		Contraflow version of FR02	938	813	73	1/2"	13	874 x 172	874 x 172	Bolt On	FR01GK
FURAKAWA											
FU01	FUR701	FL120 / FL150 Loader	710	625	95	INL	9	630 x 111	630 x 111	Flanged	
GALION											
GL01	GAL201	Grader	724	730	95	Cant	9	819 x 186	819 x 186	Bolt On	POA
GL02	GAL202	Grader	745	699	87	5/8"	11	718 x 110	718 x 110	Flanged	
GENERAL MOTORS											
GM01	GMD201	6V-71 Genset	732	651	73	5/8"	9	655 x 136	655 x 109	Flanged	
GM02	GMD506	12V-71 Genset	1060	1040	115	5/8"	9	1110 x 222	1110 x 222	Bolt On	POA
GLENER											
GE01	GLE701	R72 Harvester	965	860	134	INL	5.5	885 x 140	885 x 140	Flanged	
GROVE CRANE											
GR01	N/A	Mobile Crane	938	813	60	1/2"	13	874 x 172	874 x 172	Flanged	
GREYHOUND COACH											
RB	X-Ref	Description	H	W	T	Const	fpi	Top HP	Btm HP		
GY01	GRE801	Coach	815	953	115	5/8"	11	1040 x 186	1040 x 186	Bolt On	POA
HALLIBURTON											
HB01	HAL804	Power Pack	968	1095	100	5/8"	9	1170 x 220	1170 x 220	Bolt On	POA
HB02	HAL701	Power Pack	1620	1081	152	INL	9	1154 x 222	1154 x 222	Bolt On	POA
HB03	HAL702	Power Pack	1523	1092	134	INL	9	1154 x 222	1154 x 222	Bolt On	POA

Industrial Radiator Cores

PART NO.	CROSS REFERENCE	DESCRIPTION	CORE HEIGHT	CORE WIDTH	CORE THICK-NESS	CORE TYPE	FPI	TOP HEADER PLATE	BOTTOM HEADER PLATE	HEADER PLATE TYPE	GASKET SET
HEATER											
HR01	HTR1105	Heater core	200	140	60	1/2"	13	147 x 71	147 x 71	Flanged	
HR02	HTR1119	Heater core (2 pass)	168	102	46	1/2"	13	106 x 57	106 x 57	Flanged	
HR03	HTR1119	Heater core (Contraflow)	168	102	46	1/2"	13	106 x 57	106 x 57	Flanged	
HILLMAN											
CTH11	HIL911 / CTHI01	Minx	276	548	38	CT	12	548 x 56	548 x 56	Flanged	
HINO											
HN01	HIN833	FC Series	630	495	73	1/2"	13	505 x 90	505 x 90	Flanged	
HN02	HIN815	KLA Series / KR320	495	563	73	1/2"	13	558 x 116	558 x 116	Flanged	
HN03	N/A	Econ Diesel	560	635	60	5/8"	13	649 x 88	649 x 88	Flanged	
HN04	HIN819	AM100 / KT 725	576	559	87	1/2"	11	560 x 118	560 x 118	Flanged	
HN10	N/A	Bus	840	635	73	5/8"	11	650 x 90	650 x 90	Flanged	
HN13	HIN804	RC - RU Bus	612	648	87	5/8"	11	654 x 95	654 x 95	Flanged	
CTHN01	HIN901	Bus	478	670	76	CT	12	688 x 128	688 x 128	Flanged	
CTHN10	CTHN10	RG Bus	840	645	57	CT	14	650 x 90	650 x 90	Flanged	
CTHN19	HIN919	AM100	576	560	76	CT	12	560 x 118	560 x 118	Flanged	
CTHN21	HIN921	AM100	576	560	57	CT	15	560 x 118	560 x 118	Flanged	
CTHN23	HIN923 / CTHN01	AK174-176 / GD - 2J	560	642	57	CT	12	652 x 92	652 x 92	Flanged	
CTHN24	HIN924	SF 197 / FL & FM 187	668	638	57	CT	14	650 x 88	650 x 88	Flanged	
CTHN26	HIN926	FS Series	667	700	57	CT	13	709 x 109	709 x 109	Flanged	
CTHN27	HIN927	FC Series	630	495	76	CT	15	505 x 90	505 x 90	Flanged	
CTHN28	HIN928	FF 193K	765	645	76	CT	12	655 x 110	655 x 110	Flanged	
CTHN29	HIN929N / CTHN02	FF 197	400	396	38	CT	16	402 x 64	402 x 64	Flanged	
CTHN30	HIN936	AM	576	560	76	CT	12	560 x 118	560 x 118	Flanged	
CTHN32	HIN932 / CTHN03	FG series / FE 3W / GD 3W	582	646	57	CT	18	649 x 88	649 x 88	Flanged	
CTHN35	HIN935 / CTHN04	FC Series	430	640	57	CT	15	650 x 71	650 x 71	Flanged	
CTHN37	HIN937 / CTHN05	FDS Series / FE-2J / FL & FM - 1J	645	640	57	CT	16	650 x 70	650 x 70	Flanged	
CTHN40	HIN940	FG Ranger / FL - 1J NLA / GH - 1J	720	638	57	CT	14	652 x 72	652 x 72	Flanged	
CTHN57	HIN957	FM series	770	638	38	CT	18	651 x 90	651 x 90	Flanged	
CTHN76	HIN976 OEX	CH	740	640	38	CT	15	652 x 89	652 x 89	Flanged	
CTHN92	HIN929	FF197K / FL & FM - 1M & 3M	748	647	76	CT	11	650 x 105	650 x 105	Flanged	
HITACHI											
HT01	HIT871	EX300 Excavator	905	692	73	1/2"	13	702 x 105	702 x 105	Flanged	
HT02	N/A	ZX330 Excavator	905	890	96	INL	13	908 x 108	908 x 108	Flanged	
HT03	N/A	EX700	1000	1095	101	5/8"	11	1250 x 192	1250 x 192	Bolt On	POA
HT04	HIT835	EX3500 Excavator	800	1588	115	5/8"	9	1706 x 215	1706 x 215	Bolt On	POA
HT05	HIT818	EX1200 Excavator	1300	1302	101	5/8"	9	1393 x 214	1393 x 214	Bolt On	HT16GK
HT06	N/A	EX3600 Excavator (T&B different)	995	1080	115	5/8"	9	1195 x 215	1195 x 215	Bolt On	POA
HT07	HIT811	Excavator	1048	940	100	5/8"	9	990 x 212	990 x 212	Bolt On	POA
HT08	HIT220	Excavator	810	699	87	5/8"	11	710 x 105	710 x 105	Flanged	
HT09	N/A	EH750 Dump Truck	975	1492	101	5/8"	11	1610 x 260	1610 x 260	Bolt On	POA
HT10	HIT610	Excavator	1400	1254	115	Cant	9	1349 x 214	1349 x 214	Bolt On	POA
HT11	HIT815	EX2500 Excavator	800	1588	115	5/8"	11	1706 x 215	1706 x 215	Bolt On	POA

Industrial Radiator Cores

PART NO.	CROSS REFERENCE	DESCRIPTION	CORE HEIGHT	CORE WIDTH	CORE THICKNESS	CORE TYPE	FPI	TOP HEADER PLATE	BOTTOM HEADER PLATE	HEADER PLATE TYPE	GASKET SET
HITACHI (continued)											
HT12	HIT620SC	EX5500 Excavator (T&B different) (Steel)	875	1700	115	Cant	9	1818 x 214	1818 x 214	Bolt On	HT12GK
HT13	N/A	EX3600 Excavator (Steel)	900	1080	115	Cant	9	1195 x 215	1195 x 215	Bolt On	HT13GK
HT14	HIT621SC	EX2500-5 LT Core (Steel)	875	1700	76	Cant	9	1818 x 214	1818 x 214	Bolt On	HT12GK
HT15	HIT655SC	EX5500 - 5 (T&B different) (Steel)	1000	1700	115	Cant	9	1818 x 214	1818 x 214	Bolt On	HT12GK
MFHT15	HIT655 MAXIFUseD	EX5500-5 (T&B different)	1000	1696	123	MF	9	1820 x 214	1820 x 214	Bolt On	POA
HT16	N/A	EX1200 Excavator	1302	1255	95	INL	9	1393 x 214	1393 x 214	Bolt On	HT16GK
HT17	N/A	EX1800 Excavator (T+B different)	708	1254	115	5/8"	9	1349 x 214	1349 x 214	Bolt On	POA
HT18	HIT701	EX3600 (Steel)	1398	1251	115	INL	9	1349 x 214	1349 x 214	Bolt On	POA
HT19	HIT509 (12S)	EX700 Excavator	1000	1105	73	1/2"	9	1250 x 195	1250 x 195	Bolt On	POA
HT20	N/A	Excavator (Steel)	860	509	76	INL	6.5	512 x 124	512 x 124	Flanged	
CTHT01	HIT901 OEX	Compact Excavator	450	420	38	CT	12	425 x 63	425 x 63	Flanged	
HOLDEN											
HL01	HOL825x4	Torana	368	635	60	1/2"	13	646 x 70	646 x 70	Flanged	
HL02	HOL826x4	Torana	344	552	60	1/2"	13	551 x 57	551 x 57	Flanged	
HL03	HOL2135	Cement Mixer	533	508	73	5/8"	9	515 x 84	515 x 84	Flanged	
HL04	HOL854x5	Monaro	368	622	73	1/2"	13	628 x 75	628 x 75	Flanged	
CTHL04	HOL954x3	Monaro	368	632	57	CT	14	628 x 68	628 x 68	Flanged	
CTHL05	HOL905	EH / EJ	366	447	38	CT	14	440 x 62	440 x 62	Flanged	
CTHL10	HOL908	EH 179 engine	340	568	38	CT	14	561 x 62	561 x 52	Flanged	
CTHL11	HOL911	HD-HX	368	551	38	CT	14	551 x 49	551 x 49	Flanged	
CTHL12	HOL952	HD-HX with A / C	368	640	38	CT	14	635 x 49	635 x 49	Flanged	
CTHL13	HOL9130EX / Use CTHL12	Torana LH	368	640	38	CT	13	635 x 50	635 x 50	Flanged	
CTHL14	HOL979	WB	625	443	38	CT	13	441 x 72	441 x 72	Flanged	
CTHL68	HOL968	Commodore	545	442	57	CT	14	441 x 72	441 x 72	Flanged	
CTHL69	HOL969x4	Commodore	545	442	57	CT	16	441 x 72	441 x 72	Flanged	
CTHL90	HOL901 / CTHL01	FJ	445	405	38	CT	12	395 x 60	395 x 60	Flanged	
CTHL99	HOL990	WB	626	443	57	CT	14	441 x 72	441 x 72	Flanged	
CTHL109	HOL9109 / CTHL02	VL Commodore (HOL9109 / HOL9114)	545	432	57	CT	15	441 x 72	441 x 72	Flanged	
CTHL157	HOL9157	Rodeo	420	552	38	CT	14	556 x 47	556 x 47	Flanged	
CTHL202	HOL902 / CTHL03	FE / FB / FC / EK	390	400	38	CT	14	397 x 60	397 x 51	Flanged	
CTHL26	HOL926 / CTHL04	LC-L J Torana	344	552	38	CT	12	550 x 48	550 x 48	Flanged	
HOUGH											
HG01	N/A	JH90E Loader	820	841	133	CANT	9	895 x 198	895 x 198	Bolt On	POA
HYSTER FORKLIFT											
HY01	HYS207	H25 Forklift	352	429	73	5/8"	6.5	454 x 89	454 x 89	Flanged	
HY02	HYS787	XM250 Forklift	485	450	76	INL	9	450 x 83	450 x 83	Flanged	
HY03	HYS755	H400 Forklift	398	528	115	INL	6.5	525 x 129	525 x 129	Flanged	
HY04	HYS208	S60B Forklift	492	476	73	5/8"	9	503 x 87	503 x 87	Flanged	
HY05	HYS230	H250XL	355	460	73	5/8"	9	468 x 85	468 x 85	Flanged	
HY06	HYS750	155XL	433	580	95	INL	6.5	581 x 99	581 x 99	Flanged	

PART NO.	CROSS REFERENCE	DESCRIPTION	CORE HEIGHT	CORE WIDTH	CORE THICKNESS	CORE TYPE	FPI	TOP HEADER PLATE	BOTTOM HEADER PLATE	HEADER PLATE TYPE	GASKET SET
HYSTER FORKLIFT											
HY07	HYS211	S40 / S50	394	492	87	5/8"	9	505 x 89	505 x 89	Flanged	
HY08	HYS216	H80C	394	460	73	5/8"	9	460 x 84	460 x 84	Flanged	
HY09	HYS215	H120C	438	572	73	5/8"	9	603 x 89	603 x 89	Flanged	
HY10	HYS987	MX250 Forklift	485	445	76	INL	9	450 x 84	450 x 84	Flanged	
HY11	HYS843	H5XL Forklift	400	524	115	5/8"	9	524 x 128	524 x 128	Flanged	
HY12	HYS228	350DForklift	510	572	76	5/8"	9	606 x 93	606 x 121	Flanged	
HY13	HYS204 OEX	S40B Forklift	394	460	73	5/8"	9	505 x 89	505 x 89	Flanged	
HY14	HYS224	H50 / H60 Forklift	460	460	101	5/8"	6.5	478 x 108	478 x 108	Flanged	
HY15	HYS270	Forklift	600	587	73	5/8"	9	610 x 115	610 x 115	Flanged	
CTHY01	N/A	Forklift	530	540	57	CT	10	557 x 77	557 x 77	Flanged	
HYUNDAI											
HU01	N/A	Excavator	847	521	128	1/2"	6.5	568 x 210	568 x 210	Bolt On	POA
HU02	N/A	HL757-7A (Brass fin & 2 x solder coat)	907	519	115	INL	6.5	572 x 215	572 x 215	Bolt On	POA
HU03	N/A	Excavator	940	816	95	INL	9	830 x 115	830 x 115	Flanged	
HU04	N/A	Loader	1093	1003	115	1/2"	6.5	1044 x 247	1044 x 247	Bolt On	POA
INDUSTRIAL RADIATOR											
ID01	IND815	CF	583	589	60	5/8"	11	568 x 88	568 x 88	Flanged	
ID02	IND215	Static CF	583	557	60	5/8"	11	568 x 88	568 x 88	Flanged	
ID03	IND816	Static	580	556	73	5/8"	11	568 x 90	568 x 90	Flanged	
ID04	IND773	73 Class locomotive	800	381	192	Cant	11	382 x 218	382 x 218	Bolt On	POA
ID05	IND690	Rail Car	1760	635	115	5/8"	9	646 x 190	646 x 190	Bolt On	POA
ID06	IND720 / 220	Rail Car	890	583	115	INL	9	643 x 177	643 x 177	Bolt On	POA
ID07	IND721	Rail Car	965	774	115	INL	9	833 x 170	833 x 170	Bolt On	POA
ID08	N/A	HPU Compressor (Header offset to side)	976	700	200	INL	11	715 x 240	715 x 240	Bolt On	POA
ID09	IND801	Cement Mixer	525	498	73	1/2"	9	500 x 89	500 x 89	Flanged	
ID10	N/A	B Class Locomotive (Top Hat Headerplates)	665	826	101	5/8"	9	908 x 175	908 x 175	Bolt On	POA
INGERSOL RAND											
NG01	ING602	Drill Rig	1532	1524	87	5/8"	9	1576 x 208	1576 x 182	Bolt On	POA
NG02	N/A	XHP 1070	1523	699	87	5/8"	11	735 x 156	735 x 156	Bolt On	POA
NG03	ING601							1575 x 207	1575 x 182	Bolt On	POA
INTERNATIONAL McCORMACK											
MC01	IMC270	Tractor 574, 674	465	445	60	5/8"	6.5	451 x 64	451 x 64	Flanged	
MC02	IMC237	Tractor B414	427	445	73	5/8"	6.5	465 x 140	465 x 84	Flanged	
MC03	IMC273	Tractor 454	422	445	60	5/8"	6.5	451 x 64	451 x 64	Flanged	
MC04	IMC258	Tractor 760	518	486	101	5/8"	6.5	495 x 106	495 x 106	Flanged	
MC05	IMC266	Farmall	427	443	73	5/8"	6.5	465 x 140	465 x 140	Flanged	
MC06	IMC272	966 / 1066	610	572	101	5/8"	6.5	582 x 107	582 x 107	Flanged	
MC07	IMC263	Tractor	575	476	73	5/8"	6.5	500 x 221	500 x 106	Flanged	
MC08	IMC208	Farmall W6	575	460	60	5/8"	6.5	502 x 221	502 x 106	Flanged	
MC09	IMC221	Use MC07	570	476	73	5/8"	6.5	502 x 221	502 x 106	Flanged	
MC10	IMC210	U6 & D6	511	540	87	5/8"	6.5	620 x 140	620 x 140	Bolt On	POA
MC11	IMC774	1460 / 1480 Combine	835	635	115	Cant	5.5	655 x 150	655 x 150	Flanged	
MC12	IMC224	Tractor	613	572	87	5/8"	6.5	618 x 149	618 x 149	Bolt On	POA

Industrial Radiator Cores

PART NO.	CROSS REFERENCE	DESCRIPTION	CORE HEIGHT	CORE WIDTH	CORE THICKNESS	CORE TYPE	FPI	TOP HEADER PLATE	BOTTOM HEADER PLATE	HEADER PLATE TYPE	GASKET SET
INTERNATIONAL McCORMACK (continued)											
MC13	IMC231	Tractor 200 & B250	410	413	73	5/8"	6.5	435 x 140	435 x 83	Flanged	
MC14	IMC238	8414 Tractor	422	445	73	5/8"	9	467 x 140	467 x 83	Flanged	
MC15	IMC264	Tractor A554 & 766	510	572	101	5/8"	6.5	582 x 107	582 x 107	Flanged	
MC16	IMC232	B250 Tractor	410	413	73	5/8"	6.5	435 x 140	435 x 93	Flanged	
MC17	IMC233	TD9 Dozer (F.U.D.)	691	572	87	5/8"	6.5	654 x 140	654 x 140	Bolt On	POA
MC18	IMC265	Tractor 848188-R1	586	572	101	5/8"	6.5	582 x 107	582 x 107	Flanged	
MC23	IMC223	Farmall A	419	413	60	5/8"	6.5	432 x 168	441 x 73	Flanged	
MC24	IMC448	TD8 Dozer	578	540	87	5/8"	9	549 x 146	549 x 92	Flanged	
MC26	IMC626	TD20 Dozer (See Dresser)	1006	1060	152	INL	6.5	1130 x 238	1130 x 238	Bolt On	POA
INTERNATIONAL & IVECO											
NT01	INT8171 / VHF1022	S3600, Cummins 430HP	1104	606	73	1/2"	11	687 x 140	687 x 140	Bolt On	NT01GK
CTNT01	INT976	Acco D353	660	622	57	CT	12	635 x 84	635 x 84	Flanged	
NT01LF	INT8171 / VHF1022	S3600 low flow	1104	606	73	1/2"	11	687 x 140	687 x 140	Bolt On	NT01GK
NT02	INT5172 / VHF1475	Transtar, F4700 Cummins	1088	710	73	5/8"	11	793 x 152	793 x 152	Bolt On	POA
CTNT02	INT9117	Acco	563	623	57	CT	14	635 x 84	635 x 84	Flanged	
NT03	Use NT22LF	S Line, S2670 Hi Flow	1010	758	73	1/2"	11	820 x 172	820 x 172	Bolt On	NT03GK
NT03LF	Use NT22LF	S Line, S2760, Cummins & Detroit (LF)	1010	762	73	1/2"	11	820 x 172	820 x 172	Bolt On	NT03GK
NT04	INT8129 / VHF1476	S3600, Cummins, 370HP	956	635	73	5/8"	11	697 x 155	697 x 155	Bolt On	POA
NT05	INT877 / ML1100	Acco 1950A	767	619	73	5/8"	11	635 x 84	635 x 84	Flanged	
NT06	INT8130 / VHF1073	S Line, Cummins	1010	762	60	5/8"	11	820 x 172	820 x 172	Bolt On	POA
NT06LF	INT8130 / VHF1073	S Line Low Flow (LF)	1010	762	60	5/8"	11	820 x 172	820 x 172	Bolt On	POA
NT07	INT5110 / MLF1028	T Line Cast alloy tank, 350 Cummins	890	873	73	5/8"	9	940 x 240	940 x 206	Bolt On	NT07GK
NT08	INT887 / SP-1390	T Line 2670, 400HP Cummins	889	841	73	5/8"	11	900 x 178	900 x 178	Bolt On	LP04GK
NT09	INT8102 / ML-1089	Acco 3070A	818	686	73	1/2"	11	695 x 84	695 x 84	Flanged	
NT10	INT8740EX / INT875 (NT30)	Acco V392 4 row	660	619	60	5/8"	11	635 x 84	635 x 84	Flanged	
NT11	INT8188	Powerstar Plastic tank conversion	1171	711	60	1/2"	13	740 x 78	740 x 78	Flanged	
CTNT11	INT9199	Powerstar Plastic tank conversion	1178	711	57	CT	14	740 x 78	740 x 78	Flanged	
NT12	INT8180	S3600 Plastic tank conversion	1035	711	60	1/2"	13	740 x 78	740 x 78	Flanged	
NT13	INT8192 / VHF1982	Acco 2350	757	660	60	1/2"	13	730 x 148	730 x 148	Bolt On	NT13GK
CTNT13	INT9192	Acco 2350	757	663	57	CT	14	730 x 148	730 x 148	Bolt On	NT13GK
NT14	INT895 / SP-1673-4MLF11	Bus / Acco	686	635	73	1/2"	11	687 x 140	687 x 140	Bolt On	NT01GK
CTNT14	INT9198	Acco 2350 (Dimpled Tubes)	757	663	57	CT	14	730 x 148	730 x 148	Bolt On	NT13GK
NT15	N/A	T Line	787	667	60	5/8"	11	730 x 140	730 x 140	Bolt On	POA
CTNT15	INT940	Acco 170 / AA160	518	600	57	CT	10	606 x 64	606 x 64	Flanged	
NT16LF	INT3153 / SBS-1-1839	Transtar Low Flow	1218	826	73	5/8"	11	900 x 140	900 x 140	Bolt On	POA
NT17	INT8172 / VHF1475	Transtar	1088	711	73	1/2"	11	793 x 152	793 x 152	Bolt On	POA

Industrial Radiator Cores

PART NO.	CROSS REFERENCE	DESCRIPTION	CORE HEIGHT	CORE WIDTH	CORE THICKNESS	CORE TYPE	FPI	TOP HEADER PLATE	BOTTOM HEADER PLATE	HEADER PLATE TYPE	GASKET SET
INTERNATIONAL & IVECO (continued)											
NT18	INT232 / ML1326	AL160 / AR160	457	556	73	5/8"	9	568 x 87	568 x 87	Flanged	
NT19	INT245 / ML1329	AB110	460	683	60	5/8"	9	695 x 64	695 x 64	Flanged	
NT20	INT246 / ML1090	AA182	549	683	60	5/8"	9	695 x 64	695 x 64	Flanged	
NT21	INT231	L110-130 AR110-130	457	556	60	5/8"	9	695 x 64	695 x 64	Flanged	
NT22	INT8148 / VHF1019	S line in 5 / 8 pitch (use NT22)	1010	762	73	5/8"	11	820 x 172	820 x 172	Bolt On	POA
NT22LF	INT8148OEX / VLF1018	S line in 5 / 8 pitch 2 pass	1010	762	73	5/8"	11	820 x 172	820 x 172	Bolt On	POA
NT23LF	INT5173 / VLF1000	Transtar Low Flow	1218	810	60	5/8"	11	900 x 140	900 x 140	Bolt On	POA
NT24	INT8145	Bus	688	635	73	1/2"	11	690 x 140	690 x 140	Bolt On	POA
NT25	INT8153 / VHF1772	Acco 2350E	795	660	73	1/2"	13	696 x 84	696 x 84	Flanged	
NT26	INT5182 / S24080 / 4MLF11	Powerstar 1600sq	1109	921	73	5/8"	11	987 x 140	987 x 140	Bolt On	NT26GK
NT27	INT8149	Acco 2350	745	683	73	5/8"	11	696 x 84	696 x 84	Flanged	
NT28	INT888 / SP-3261 / 3MLF11	T line	890	840	60	5/8"	11	902 x 178	902 x 178	Bolt On	AR08GK
NT30	INT874 (5 row)	V392 Acco 5 row	660	619	73	5/8"	11	635 x 84	635 x 84	Flanged	
NT31	INT8150 / ML-1580	Acco	669	686	73	1/2"	11	695 x 84	695 x 84	Flanged	
NT32	INT8133	Scout	550	556	60	5/8"	13	561 x 68	561 x 68	Flanged	
NT33	INT3154 / S17710-4MLF11	Transtar	990	841	73	5/8"	11	900 x 140	900 x 140	Bolt On	POA
MFNT33	S17710-4MLF11	Transtar 500HP 1994on	990	848	72	OE	11	900 x 140	900 x 140	Bolt On	NT39GK
NT34	SBS-1-1763 / INT895AC	Phaser Acco with aftercooler	686	622	76	5/8INL	13	687 x 140	687 x 140	Bolt On	NT01GK
NT35	INT3157 / SBS-1696 (5 row)	T Line 2670 Cummins	787	667	73	5/8"	11	730 x 140	730 x 140	Bolt On	POA
NT36	INT2400EX / ML1328	Acco170 / AA160	518	603	60	5/8"	11	606 x 64	606 x 64	Flanged	
CTNT37	INT9161 / CTNT37	Acco 2350G	795	686	75	CT	16	696 x 84	696 x 84	Flanged	
NT38	INT894 OEX	Acco	818	619	73	5/8"	11	635 x 84	635 x 84	Flanged	
NT39	INT539LF / SBS-1-1839	Transtar	1218	841	73	5/8"	11	902 x 140	902 x 140	Bolt On	NT39GK
NT40	INT2118	Tractor	586	492	101	5/8"	9	497 x 108	497 x 108	Flanged	
NT41	INT883	Acco 1952A	767	622	73	1/2"	11	635 x 83	635 x 83	Flanged	
CTNT41	INT983	Acco 1952A	767	622	76	CT	12	635 x 84	635 x 84	Flanged	
CTNT149	INT9149A OEX	Acco 2350	745	687	57	CT	15	696 x 84	696 x 84	Flanged	
NT42	Use NT35	T - Line 2670	787	667	73	5/8"	11	730 x 140	730 x 140	Bolt On	POA
NT43	INT2141	956XL Tractor	490	508	101	5/8"	9	512 x 102	512 x 102	Flanged	
NT44	INT8134 / MLF1344	Transtar F4370	946	1016	73	5/8"	11	1097 x 170	1097 x 170	Bolt On	POA
NT45	INT8183 OEX	Use NT26	1109	921	73	5/8"	11	987 x 140	987 x 140	Bolt On	POA
NT46	INT8126	Use INT874	660	619	60	5/8"	11	635 x 84	635 x 84	Flanged	
NT47	INT230	L 190 / KB8	632	603	73	5/8"	11	613 x 82	613 x 82	Flanged	
NT48	INT8179	Acco	686	603	73	5/8"	11	687 x 140	687 x 140	Bolt On	NT01GK
NT49	INT5109	T Line Cast alloy tank, 300 Cummins	890	873	60	5/8"	9	940 x 240	940 x 206	Bolt On	POA
NT50	INT886	AA184, C1840 V392	549	686	46	1/2"	11	695 x 84	695 x 84	Flanged	

Industrial Radiator Cores

PART NO.	CROSS REFERENCE	DESCRIPTION	CORE HEIGHT	CORE WIDTH	CORE THICKNESS	CORE TYPE	FPI	TOP HEADER PLATE	BOTTOM HEADER PLATE	HEADER PLATE TYPE	GASKET SET
INTERNATIONAL & IVECO (continued)											
NT51	INT278	756,760 Series Tractor	519	492	101	5/8"	9	500 x 108	500 x 108	Flanged	
NT52	INT5127	F4870 / Atkinson	1040	873	73	5/8"	11	940 x 240	940 x 206	Bolt On	NT07GK
NT53	INT8101	Acco	559	622	73	1/2"	9	635 x 84	635 x 84	Flanged	
CTNT66	INT966 OEX	Acco V392 Petrol	549	686	76	CT	10	695 x 84	695 x 84	Flanged	
CTNT102	INT9102	Acco	818	686	76	CT	12	695 x 84	695 x 84	Flanged	
CTNT184	INT9184	Acco 2350E C240	745	660	57	CT	13	696 x 84	696 x 84	Flanged	
ISEKI											
CTIS01	ISE901 / CTIS01	Tractor T7000	550	458	76	CT	12	470 x 105	470 x 105	Flanged	
CTIS22	ISE902	Tractor	590	458	76	CT	12	470 x 105	470 x 105	Flanged	
CTIS02	ISE904 OEX	Tractor	364	345	38	CT	12	360 x 66	360 x 66	Flanged	
CTIS03	ISE903 OEX / CTIS02	Tractor	364	345	57	CT	10	360 x 66	360 x 66	Flanged	
IS01	ISE207	FZ75	588	460	87	5/8"	9	465 x 102	465 x 102	Flanged	
CTIS04	N/A	Tractor	264	345	57	CT	10	360 x 66	360 x 66	Flanged	
ISUZU											
IZ01	ISU885	FVR900 (16S Pitch)	620	560	73	5/8"	13	565 x 89	565 x 89	Flanged	
IZ02	N/A	NPR	590	559	46	1/2"	13	572 x 57	572 x 57	Flanged	
IZ03	ISU831	FVR	628	559	60	1/2"	13	565 x 89	565 x 89	Flanged	
IZ04	ISU850	Truck	515	457	60	1/2"	13	490 x 62	490 x 62	Flanged	
IZ05	ISU814	SBR	500	521	73	1/2"	13	526 x 85	526 x 85	Flanged	
IZ06	ISU885	FVR (12S Pitch)	620	559	73	1/2"	13	565 x 89	565 x 89	Flanged	
IZ07	ISU213	Industrial	580	556	73	5/8"	11	568 x 90	568 x 90	Flanged	
IZ08	ISU860	FVR / FVM / FVC	680	556	73	5/8"	11	568 x 90	568 x 90	Flanged	
IZ09	ISU817	VCR 420	566	524	73	5/8"	13	528 x 84	528 x 84	Flanged	
CTIZ01	N/A	NKR	590	545	38	CT	16	572 x 60	572 x 60	Flanged	
CTIZ07	ISU973 / ISU993N / CTIZ09	FVM / FSR900	800	636	57	CT	15	645 x 74	645 x 74	Flanged	
CTIZ08	ISU970	NPR	455	475	38	CT	14	492 x 58	492 x 58	Flanged	
CTIZ13	ISU950	Truck	515	470	38	CT	15	490 x 62	490 x 62	Flanged	
CTIZ14	ISU914 / CTIZ02	SBR 720	500	525	57	CT	14	526 x 85	526 x 85	Flanged	
CTIZ17	ISU917 / CTIZ03	VCR 420	566	524	57	CT	13	528 x 84	528 x 84	Flanged	
CTIZ20	ISU972	FFR	600	636	57	CT	15	645 x 72	645 x 72	Flanged	
CTIZ22	ISU975	NPS	570	470	57	CT	14	490 x 74	490 x 74	Flanged	
CTIZ29	ISU929 / CTIZ04	JCR500S	620	560	38	CT	15	565 x 72	565 x 72	Flanged	
CTIZ329	ISU929x4 (3 row)	JCR500S	620	560	38	CT	15	565 x 72	565 x 72	Flanged	
CTIZ31	ISU931 / CTIZ05	FVR	628	560	76	CT	14	565 x 90	565 x 90	Flanged	
CTIZ32	ISU932	NPR	545	475	38	CT	16	490 x 74	490 x 74	Flanged	
CTIZ49	ISU949 / CTIZ06	FSR	628	540	57	CT	15	565 x 76	565 x 76	Flanged	
CTIZ51	ISU951 / CTIZ07	NPR400	520	470	38	CT	14	498 x 62	498 x 62	Flanged	
CTIZ60	ISU960	FVM / FVR	683	560	57	CT	14	569 x 90	569 x 90	Flanged	
CTIZ65	ISU965	NPR	590	560	38	CT	14	572 x 59	572 x 59	Flanged	
CTIZ72	ISU972	Truck	600	636	57	CT	15	645 x 72	645 x 72	Flanged	
CTIZ87	ISU987 / CTIZ08	NPR	518	472	38	CT	18	492 x 57	492 x 57	Flanged	
CTIZ93	ISU993N use CTIZ07	FVR	800	638	57	CT	16	645 x 73	645 x 73	Flanged	
CTIZ98	ISU998 / CTIZ10	FFR	600	636	38	CT	18	645 x 72	645 x 72	Flanged	
CTIZ61	ISU961 / CTIZ11	FFR	698	628	57	CT	16	645 x 75	645 x 75	Flanged	

PART NO.	CROSS REFERENCE	DESCRIPTION	CORE HEIGHT	CORE WIDTH	CORE THICKNESS	CORE TYPE	FPI	TOP HEADER PLATE	BOTTOM HEADER PLATE	HEADER PLATE TYPE	GASKET SET
JAGUAR											
JG01	JAG215	3.4 / 3.8L	433	432	75	1/2"	11	436 x 83	436 x 83	Flanged	
CTJG01	JAG901 / CTJG01	3.8L	435	424	57	CT	10	432 x 83	432 x 83	Flanged	
JG02	JAG819	E Type	438	492	75	5/8"	11	493 x 78	493 x 78	Flanged	
JG03	JAG217	Mark 2	438	432	60	1/2"	13	432 x 70	432 x 70	Flanged	
CTJG12	JAG912	XJ V12 Series 2&3	696	454	57	CT	12	462 x 81	462 x 81	Flanged	
CTJG14	JAG914 / CTJG02	XJ6 4.2L	650	453	57	CT	12	462 x 80	462 x 80	Flanged	
CTJG15	JAG904	4.2L	654	395	57	CT	14	407 x 80	407 x 80	Flanged	
JCB											
JB01	JCB803	344-384 Tractor	424	495	46	5/8"	9	510 x 64	510 x 64	Flanged	
JB02	N/A	Backhoe	445	572	60	1/2"	11	583 x 83	583 x 83	Flanged	
JB03	JCB801	3CX Backhoe 1988 on	440	460	60	5/8"	13	467 x 70	467 x 70	Flanged	
JB04	JCB210	Tractor	475	572	73	5/8"	6.5	585 x 84	585 x 84	Flanged	
JEEP											
CTJE01	JEE901	Cherokee	785	280	57	CT	18	286 x 70	286 x 70	Flanged	
CTJE02	Special Build	Cherokee	787	272	38	CT	12	284 x 59	284 x 59	Flanged	
JOHN DEERE											
JD01	JOD223	4010 / 4020 (See also JD34)	618	497	73	5/8"	9	506 x 133	506 x 83	Flanged	
CTJD01	JOD963	5510 N	435	530	57	CT	10	535 x 92	535 x 92	Flanged	
CTJD02	JOD921	Pump	655	660	57	CT	12	670 x 115	670 x 115	Flanged	
JD02	JOD236	4230	645	493	87	5/8"	9	510 x 132	510 x 100	Flanged	
JD03	JOD2140	2040 / Combine	525	485	73	5/8"	9	490 x 86	490 x 86	Flanged	
JD04	JOD250	699 / 1900	545	635	87	5/8"	9	652 x 112	652 x 112	Flanged	
JD05	JOD233	Tractor 8630	875	699	101	5/8"	9	709 x 108	709 x 108	Flanged	
JD06	JOD226	4640 / 4840 Tractor	763	667	101	5/8"	9	680 x 163	680 x 100	Flanged	
JD07	JOD240	Tractor 4460 / 4480	740	556	87	5/8"	9	557 x 130	557 x 100	Flanged	
JD08	JOD247N	Tractor 2510 powershift	525	476	73	5/8"	9	489 x 86	489 x 86	Flanged	
JD09	JOD219	Tractor 1020	432	460	60	5/8"	9	475 x 82	475 x 82	Flanged	
JD10	JOD220	Loader	508	349	73	5/8"	9	356 x 82	356 x 82	Flanged	
JD11	JOD246	1750, 2240	475	349	73	5/8"	9	355 x 80	355 x 80	Flanged	
JD12	JOD354	315C Backhoe	590	540	46	5/8"	11	555 x 90	555 x 90	Flanged	
JD13	JOD824	5020 / 7520 (Brass fin)	709	648	73	1/2"	9	656 x 151	656 x 84	Flanged	
JD14	JOD444	770A Grader	787	699	73	5/8"	9	718 x 110	718 x 110	Flanged	
JD15	JOD278	850B Dozer	835	524	152	CANT	9	570 x 232	570 x 232	Bolt On	POA
JD16	JOD243	Grader	672	524	73	1/2"	6.5	557 x 86	557 x 86	Flanged	
JD17	JOD853	Tractor	610	460	73	5/8"	13	488 x 95	488 x 95	Flanged	
JD18	JOD231	4240	686	556	73	5/8"	9	556 x 153	556 x 99	Flanged	
JD21	JOD221	5020 / 7520	706	651	73	5/8"	9	656 x 151	656 x 84	Flanged	
JD22	JOD245	4755	724	651	101	5/8"	9	655 x 110	655 x 110	Flanged	
JD23	JOD727	7200 / 7700 Header	825	678	95	INL	5.5	720 x 110	720 x 110	Flanged	
JD24	JOD230	440 Tractor (o / hang)	740	556	87	5/8"	9	557 x 153	557 x 100	Flanged	
JD25	JOD274	7600 Tractor	713	556	73	5/8"	9	557 x 108	557 x 108	Flanged	
JD26	JOD253	Tractor (10mm over hang)	570	476	60	5/8"	6.5	475 x 135	475 x 83	Flanged	
JD27	JOD218	3020 Tractor	572	460	73	5/8"	9	475 x 135	475 x 83	Flanged	
JD28	JOD239	4440 Tractor (central)	740	556	87	5/8"	9	557 x 153	557 x 100	Flanged	
JD29	JOD234	Grader	748	635	73	5/8"	9	655 x 110	655 x 110	Flanged	

Industrial Radiator Cores

PART NO.	CROSS REFERENCE	DESCRIPTION	CORE HEIGHT	CORE WIDTH	CORE THICKNESS	CORE TYPE	FPI	TOP HEADER PLATE	BOTTOM HEADER PLATE	HEADER PLATE TYPE	GASKET SET
JOHN DEERE (continued)											
JD30	JOD773	9650 Combine	960	625	95	INL	4.5	655 x 130	655 x 130	Flanged	
JD31	JOD235	4430 Tractor	690	556	87	5/8"	9	557 x 153	557 x 100	Flanged	
JD32	N/A	Combine	545	635	133	CANT	6.5	655 x 150	655 x 150	Flanged	
JD33	JOD241	4250 Tractor	740	556	87	5/8"	9	565 x 127	565 x 100	Flanged	
JD34	N/A	4010 / 4020 (see also JD01)	618	492	60	5/8"	9	506 x 133	506 x 84	Flanged	
JD35	JOD225	9940 Cotton Harvester	743	651	87	5/8"	9	655 x 110	655 x 110	Flanged	
KATO											
KT01	KAT609	Excavator	1010	889	73	5/8"	9	952 x 175	952 x 175	Bolt On	POA
KT02	KAT606	Excavator	600	635	95	CANT	9	630 x 110	630 x 110	Flanged	
KAWASAKI											
KA01	N/A	Excavator	1025	795	152	INL	9	880 x 220	880 x 220	Bolt On	POA
KA02	KAW801	Excavator	1025	795	115	5/8"	11	880 x 220	880 x 220	Bolt On	POA
KENWORTH											
KW01	KEN506 / MLF1038	K100C, 1200" Cast alloy tanks	997	762	115	5/8"	11	816 x 186	816 x 186	Bolt On	KW01GK
KW02	KEN604 / MLF1027	K100C, 1200" Cast alloy tanks	997	762	87	5/8"	11	816 x 186	816 x 186	Bolt On	KW01GK
KW03	KEN814 / MLF1554 / VHF1005	K100 cabover, T404, T600, T650, T900	990	800	73	1/2"	11	860 x 140	860 x 140	Bolt On	KW03GK
KW04	KEN849 / MLF1557	T604 Conventional	1105	838	73	1/2"	11	900 x 140	900 x 140	Bolt On	KW04GK
KW05	KEN311 / MLF1032	W Model, SAR, 1400" steel tanks	890	1032	115	5/8"	9	1105 x 186	1105 x 186	Bolt On	KW05GK
KW06	KEN832 / MLF1110 / MLF1558	T950, C500, C501	889	1003	73	1/2"	11	1073 x 140	1073 x 140	Bolt On	KW06GK
KW07	KEN824 / MLF1492	T440, T480, K100 Up to 370 HP	990	800	60	1/2"	11	860 x 140	860 x 140	Bolt On	KW03GK
KW08	KEN310 (SP-3831)	T600 / T650 (4 pass)	1016	857	87	5/8"	11	918 x 186	918 x 186	Bolt On	KW08GK
KW09	KEN508 / MLF1039	K100 1360Sq Heavy Duty	1016	857	115	5/8"	11	918 x 186	918 x 186	Bolt On	POA
KW10	KEN601	W 924R	997	762	76	5/8"	9	816 x 186	816 x 186	Bolt On	KW01GK
KW11	KEN523 / (SP-3845)	SAR Cummins (LF)	952	921	115	5/8"	11	990 x 178	990 x 178	Bolt On	
KW12	KEN526 / VLF1006	T400 Cummins(LF)	831	733	73	5/8"	13	816 x 186	816 x 186	Bolt On	KW01GK
KW12LF	KEN526LF	T400 Contraflow	831	733	73	5/8"	13	816 x 186	816 x 186	Bolt On	KW01GK
KW13LF	KEN530 / VLF1004	L700 / L710 (LF)	1016	730	101	5/8"	11	816 x 186	816 x 186	Bolt On	KW01GK
KW14	KEN310LF / MLF1451	K1001360SqContraflow (LF)	1016	857	101	5/8"	11	918 x 186	918 x 186	Bolt On	KW01GK
KW15	KEN310 (High Flow)	K100 1360Sq (High Flow no baffles)	1016	857	101	5/8"	11	918 x 186	918 x 186	Bolt On	KW01GK
KW15LF	KEN535 use KEN310 or LF	K100 1360Sq Cummins(LF)	1016	857	101	5/8"	11	918 x 186	918 x 186	Bolt On	KW15GK
KW16	KEN880 / MLF2009	T408	964	1080	73	5/8"	13	1159 x 140	1159 x 140	Bolt On	KW16GK
KW17	MLF1948	K108 ISX	1125	800	73	1/2"	11	860 x 140	860 x 140	Bolt On	KW03GK
KW18	KEN833 / MLF1900	T608 / T658 / T908	1070	1080	73	1/2"	13	1159 x 140	1159 x 140	Bolt On	KW16GK

PART NO.	CROSS REFERENCE	DESCRIPTION	CORE HEIGHT	CORE WIDTH	CORE THICK-NESS	CORE TYPE	FPI	TOP HEADER PLATE	BOTTOM HEADER PLATE	HEADER PLATE TYPE	GASKET SET
KENWORTH (continued)											
KW19	KEN613	1400 sq Young alloy tank	890	1016	101	5/8"	11	1105 x 203	1105 x 186	Bolt On	POA
CTKW20	KEN950 / CTKW20	T300	718	670	57	CT	14	680 x 76	680 x 76	Flanged	
KW21LF	VLF1002	T600 / T650 / K100E N14 Low Flow	1016	841	76	1/2"	13	918 x 186	918 x 186	Bolt On	KW21GK
KW22	KEN545 / MLF1525	T650	1100	794	73	5/8"	11	860 x 140	860 x 140	Bolt On	KW03GK
KW23	KEN841	T300	1000	610	73	1/2"	11	687 x 140	687 x 140	Bolt On	NT01GK
KW24	KEN540	T400, T450	838	714	73	5/8"	13	773 x 140	773 x 140	Bolt On	POA
KW25	MLF1944	Kenworth K108 Acert	1125	794	101	1/2"	13	859 x 178	859 x 178	Bolt On	POA
KW26	MLF2107	K200	1125	800	101	1/2"	11	859 x 178	859 x 178	Bolt On	POA
KIA											
CTKI01	KIA901 OEX	Ceres	377	470	38	CT	14	476 x 48	476 x 48	Flanged	
KOBELCO											
KB01	N/A	Excavator	690	562	76	INL	13	568 x 89	568 x 89	Flanged	
KOMATSU											
KM01	KOM585B	HD785, HD785-5, HD985-5 Dump Truck	1298	1520	87	5/8"	9	1602 x 214	1602 x 214	Bolt On	KM01GK
KM02	KOM7480	PC480 - 3 Excavator	1050	910	76	INL	11	920 x 98	920 x 98	Flanged	
KM03	KOM7146	D475 Aftercooler	TBA	670	76	INL	9	725 x 168	725 x 168	Bolt On	POA
KM04	KOM747B	WA180 Loader	665	625	76	INL	13	625 x 85	625 x 85	Flanged	
KM05	KOM741B	WA500-1 Loader	1058	1081	133	INL	9	1166 x 240	1166 x 240	Bolt On	POA
KM06	KOM7200	PC1100 Excavator	1300	1295	87	5/8"	11	1450 x 214	1450 x 214	Bolt On	POA
KM07	N/A	PC300	1050	827	76	INL	13	835 x 84	835 x 84	Flanged	
KM08	KOM751B	WA500-3	1200	1081	134	INL	6.5	1166 x 240	1166 x 240	Bolt On	POA
KM09	KOM765B	HD465-5	1017	1355	76	INL	9	1432 x 215	1432 x 215	Bolt On	POA
KM10	N/A	HD325-6 / HD405	850	1230	96	INL	11	1334 x 194	1334 x 194	Bolt On	POA
KM11	KOM744B (8 row)	D375-2 (Dummy row)	1360	1378	152	INL	9	1460 x 210	1460 x 210	Bolt On	POA
KM12	KOM928NPN	PC220-3 Excavator	813	724	46	1/2"	13	738 x 83	738 x 83	Flanged	
CTKM13	KOM9203 / CTKM01	Excavator	1050	910	76	CT	10	922 x 100	922 x 100	Flanged	
KM13	N/A	Dozer	978	975	115	INL	6.5	1060 x 175	1060 x 175	Bolt On	POA
KM14	KOM7203B	Excavator	1050	912	95	INL	9	922 x 100	922 x 100	Flanged	
CTKM14	KOM918	Forklift	530	555	57	CT	10	557 x 80	557 x 80	Flanged	POA
KM15	N/A	D85-18	1046	1030	134	INL	6.5	1120 x 194	1120 x 194	Bolt On	POA
KM16	KOM7470B / KOM770B	WA470-3	1000	859	134	INL	9	932 x 214	932 x 214	Bolt On	POA
KM17	KOM749B	WA470	948	880	115	INL	9	887 x 133	887 x 133	Flanged	
KM18	KOM719	Forklift	303	498	57	INL	6.5	505 x 70	505 x 70	Flanged	
KM19	KOM744B (7 row)	D375-2	1360	1378	134	INL	9	1460 x 210	1460 x 210	Bolt On	POA
CTKM19	KOM919	Forklift	303	495	57	CT	10	505 x 70	505 x 70	Flanged	
KM20	N/A	PC500 Excavator	950	914	87	1/2"	11	922 x 102	922 x 102	Flanged	
CTKM28	KOM928 / CTKM02	PC220-3 Excavator	813	730	76	CT	10	738 x 83	738 x 83	Flanged	
KM21	KOM642	WA700	1431	1495	152	Cant	9	1627 x 270	1627 x 270	Bolt On	POA
KM22	KOM7375	D375A	1361	1325	134	INL	9	1405 x 208	1405 x 208	Bolt On	POA
KM23	KOM745 (steel)	D475 Dozer (CTR Bars)	1584	1410	134	INL	9	1422 x 208	1422 x 208	Bolt On	POA

Industrial Radiator Cores

PART NO.	CROSS REFERENCE	DESCRIPTION	CORE HEIGHT	CORE WIDTH	CORE THICKNESS	CORE TYPE	FPI	TOP HEADER PLATE	BOTTOM HEADER PLATE	HEADER PLATE TYPE	GASKET SET
KOMATSU (continued)											
KM24	KOM748 (steel)	WA450 Loader	880	880	115	INL	6.5	890 x 130	890 x 130	Bolt On	POA
KM25	KOM740B	HD465 Dump Truck (see also KM09)	1017	1336	95	INL	9	1432 x 215	1432 x 215	Bolt On	POA
KM26	KOM703 (steel)	D50 & D50A Dozer	597	625	115	INL	6.5	714 x 175	714 x 175	Bolt On	POA
KM27	N/A (steel)	D475 (CTR BARS)	1668	1540	133	INL	9	1600 x 208	1600 x 208	Bolt On	POA
KUBOTA											
KU01	KUB204	Tractor	270	349	46	5/8"	9	358 x 96	358 x 66	Flanged	
CTKU01	KUB927	Diesel	325	350	57	CT	10	353 x 66	353 x 66	Flanged	
KU02	KUB806	Tractor	442	445	60	1/2"	9	462 x 76	462 x 76	Flanged	
KU03	KUB802	Tractor	270	343	60	5/8"	9	355 x 83	355 x 64	Flanged	
KU04	N/A	Tractor	325	343	60	1/2"	11	353 x 66	353 x 66	Flanged	
KU05	KUB805	Tractor	425	492	73	5/8"	11	500 x 80	500 x 80	Flanged	
CTKU05	KUB905 OEX	Tractor	425	492	57	CT	10	500 x 80	500 x 80	Flanged	
KU06	N/A	Lighting Tower	375	420	46	1/2"	11	425 x 50	425 x 50	Flanged	
CTKU06	CTKU01 OEX	Gen Set	525	549	57	CT	14	545 x 60	545 x 60	Flanged	
KU07	KUB827	use KU04	325	343	60	1/2"	9	353 x 66	353 x 66	Flanged	
CTKU07	KUB907	Tractor	375	420	38	CT	12	425 x 47	425 x 47	Flanged	
CTKU08	KUB918	Tractor	260	385	38	CT	11	394 x 46	394 x 46	Flanged	
KU08	KUB815	Tractor	540	540	60	5/8"	9	546 x 77	546 x 77	Flanged	
CTKU09	N/A	Lighting Tower	425	512	38	CT	14	501 x 51	501 x 51	Flanged	
CTKU19	KUB919OEX	Tractor	400	492	38	CT	12	497 x 48	497 x 48	Flanged	
LANSING											
LA01	LAN704	Forklift	500	430	76	INL	11	437 x 77	437 x 77	Flanged	
LEADER											
LE01	LEA806	Truck	686	635	76	1/2"	11	687 x 140	687 x 140	Bolt On	NT01GK
LE02	LEA201	Truck	679	683	76	5/8"	11	696 x 102	696 x 102	Flanged	
LE03	LEA202	Truck	679	683	101	5/8"	11	697 x 107	697 x 107	Flanged	
LE04	LEA403	Truck	866	683	101	5/8"	11	738 x 176	738 x 176	Bolt On	POA
LEYLAND											
LY01	LEY213	Bus	635	572	60	5/8"	11	572 x 78	572 x 78	Flanged	
LY02	LEY208	Comet	635	556	60	5/8"	9	559 x 84	559 x 84	Flanged	
LY03	LEY212	Hippo	632	572	73	5/8"	11	578 x 97	578 x 97	Flanged	
LY04	N/A	Tractor	422	508	46	5/8"	9	509 x 65	509 x 65	Flanged	
LY05	LEY836	Mastiff	522	572	73	5/8"	13	581 x 84	581 x 84	Flanged	
CTLY06	LEY906 / CTLY06	National Bus	594	790	57	CT	14	813 x 84	813 x 84	Flanged	
LY06	N/A	Tractor	422	483	60	1/2"	6.5	509 x 65	509 x 65	Flanged	
LIEBHERR											
LH01	N/A	Excavator	1447	286	152	Cat	9	297 x 167	297 x 167	Flanged	
LH02	LIE602	R994 Excavator	1447	397	152	Cat	9	395 x 167	395 x 167	Flanged	
LINCOLN WELDER											
LN01	Lincoln	Advantage 500 CA-4535	590	559	60	1/2"	11	558 x 81	558 x 81	Flanged	
CTLN05	LIN905 / CTLN05	Welder	476	478	38	CT	13	482 x 62	482 x 62	Flanged	
CTLN01	LIN903 OEX	Welder	375	478	38	CT	13	480 x 68	480 x 48	Flanged	
LN02	LIN805	Welder	476	476	46	5/8"	13	482 x 62	482 x 63	Flanged	

PART NO.	CROSS REFERENCE	DESCRIPTION	CORE HEIGHT	CORE WIDTH	CORE THICKNESS	CORE TYPE	FPI	TOP HEADER PLATE	BOTTOM HEADER PLATE	HEADER PLATE TYPE	GASKET SET
LINCOLN WELDER (continued)											
LN03	LIN802	Welder	610	572	46	1/2"	11	595 x 90	595 x 90	Flanged	
LN04	N/A	Welder	591	546	73	1/2"	11	561 x 83	561 x 83	Flanged	
MACK											
MK01	MAC531 / MLF1056	Superliner, CLR	1118	873	73	5/8"	11	923 x 158	923 x 158	Bolt On	MK05GK
MK02	MAC329 / VHF1641	CH, MH, Ultraliner, Cruiseline	981	873	73	5/8"	11	923 x 158	923 x 158	Bolt On	POA
MK03	MAC835 / VHF1506	CHR	873	1016	73	1/2"	13	1066 x 160	1066 x 160	Bolt On	POA
MK04	MAC322 / MLF1029	R Model, Cast alloy tank 350 Cummins	737	873	87	5/8"	11	943 x 152	943 x 152	Bolt On	MK04GK
MK05	MAC836	Titan (Heavy duty)	1118	876	73	1/2"	11	923 x 158	923 x 158	Bolt On	MK05GK
MK06	MAC325 / MLF1076	Econodyne X50 / R model	1098	778	73	5/8"	11	838 x 162	838 x 162	Bolt On	MK14GK
MK07	MAC617 / MLF1050	R Model Fiberglass canopy Steel Tank	838	873	101	5/8"	11	945 x 175	945 x 175	Bolt On	POA
MK08	MAC324B	Econodyne (Central)	1098	778	87	5/8"	11	838 x 162	838 x 162	Bolt On	MK14GK
MK09	MAC837 (12S)	CH (see also MK24)	747	1016	73	1/2"	13	1066 x 160	1066 x 160	Bolt On	MK10GK
MK10	MAC834 (12S)	CH (Check core thickness in gusset)	747	1016	87	1/2"	11	1066 x 160	1066 x 160	Bolt On	MK10GK
MK11	MAC618	R model	737	873	73	5/8"	11	943 x 152	943 x 152	Bolt On	MK04GK
MK12	MAC516 / MLF1049	R Model Steel canopy	737	873	73	5/8"	11	945 x 175	945 x 175	Bolt On	POA
MK13	MAC220	F Model	914	714	101	5/8"	11	719 x 163	719 x 109	Flanged	
MK14	MAC324A	Econodyne (30mm oh)	1098	778	87	5/8"	11	838 x 162	838 x 162	Bolt On	MK14GK
MK15	MCA895	Quantum	980	711	60	1/2"	11	727 x 86	727 x 86	Flanged	
MK16	MAC828 / VHF1469	Metroliner (Central)	1009	778	87	5/8"	11	838 x 162	838 x 162	Bolt On	MK14GK
MK17	MAC840	Plastic tank conversion	735	1003	60	1/2"	13	1030 x 70	1030 x 70	Flanged	
MK18	Use MK11	Use MK11	737	873	73	5/8"	11	943 x 152	943 x 152	Bolt On	MK04GK
MK19	MAC619	R700 Fiberglass canopy	1020	889	101	5/8"	11	945 x 175	945 x 175	Bolt On	POA
MK20	MAC828	Metroliner (30mm oh)	1009	778	87	5/8"	11	838 x 162	838 x 162	Bolt On	MK20GK
MK21	MAC899	Magnum 385ti / 420ti / 520	983	787	60	1/2"	13	803 x 86	803 x 86	Flanged	
MK22	MAC205	B61	695	540	87	5/8"	11	540 x 203	540 x 95	Flanged	
MK23	REN329	Passenger Bus	750	651	87	5/8"	11	647 x 103	647 x 103	Flanged	
MK24	MAC837 OEX	CH	747	1016	73	5/8"	13	1066 x 160	1066 x 160	Bolt On	MK10GK
MK25	MAC834 (16S)	CH (Check core thickness in gusset)	747	1016	87	5/8"	11	1066 x 160	1066 x 160	Bolt On	MK10GK
CTMK32	MAC932 / CTMK01	Midliner / 260G	770	650	57	CT	13	650 x 105	650 x 105	Flanged	
MK26	MAC215	F Model	918	714	87	5/8"	11	719 x 163	719 x 109	Flanged	
CTMK01	MAC996	Vision	915	718	57	CT	14	747 x 71	747 x 71	Flanged	
MK27	MAC221	Army X50	737	873	87	5/8"	11	943 x 175	943 x 152	Bolt On	MK04GK
MK28		Superliner	875	875	73	5/8"	11	950 x 140	950 x 140	Bolt On	POA
MK29	MAC627	MCR	865	746	101	5/8"	11	816 x 186	816 x 186	Bolt On	POA
MK30	MAC898	Quantum (see also MK15)	980	711	60	1/2"	13	727 x 86	727 x 86	Flanged	
MAN											
MN01	MAN810	Bus	632	667	73	5/8"	11	702 x 100	702 x 100	Flanged	
MN02	MAN219	Bus	660	714	73	5/8"	9	702 x 100	702 x 100	Flanged	
MN03	MAN215	Bus	700	699	87	5/8"	9	707 x 100	707 x 100	Flanged	
MN04	MAN825 OEX	Bus / Excel	710	714	73	5/8"	11	745 x 110	745 x 110	Flanged	

Industrial Radiator Cores

PART NO.	CROSS REFERENCE	DESCRIPTION	CORE HEIGHT	CORE WIDTH	CORE THICK-NESS	CORE TYPE	FPI	TOP HEADER PLATE	BOTTOM HEADER PLATE	HEADER PLATE TYPE	GASKET SET
MARMON											
MR01	N/A	Truck	969	1029	60	1/2"	11	1100 x 178	1100 x 178	Bolt On	POA
MASSEY HARRIS											
MS01	MAS210	Tractor	476	492	73	5/8"	6.5	502 x 156	502 x 92	Flanged	
MS02	N/A	699 Tractor	603	470	73	1/2"	11	477 x 84	477 x 84	Flanged	
MAZDA											
MZ01	MAZ811x4	Capella Rotary	330	457	60	1/2"	9	457 x 60	457 x 60	Flanged	
CTMZ42	MAZ942	B2200 (Diesel)	375	490	38	CT	16	498 x 64	498 x 64	Flanged	
CTMZ61	MAZ961	B2200	400	570	38	CT	14	575 x 46	575 x 46	Flanged	
CTMZ88	MAZ988	T4000	580	520	57	CT	15	530 x 80	530 x 80	Flanged	
MERLO											
CTML01	CTML01	Telehandler	500	430	95	CT	12	437 x 110	437 x 110	Flanged	
MERCEDES											
ME01	MER836	1418 / 1518 / 1621	570	622	73	1/2"	11	628 x 95	630 x 79	Flanged	
ME02	MER976NPN	2236 Truck / OM402	535	622	60	1/2"	13	620 x 70	620 x 70	Flanged	
ME03	MER8107	Bus	800	635	87	1/2"	11	640 x 103	640 x 103	Flanged	
ME04	MER881	Bus	700	673	73	1/2"	11	686 x 86	686 x 86	Flanged	
ME05	MER869	2223 Truck	747	667	87	5/8"	13	680 x 105	680 x 105	Flanged	
ME06	N/A	Bus / LP1624	670	635	60	1/2"	11	642 x 103	642 x 103	Flanged	
ME07	MER846	2648 Truck	525	619	60	5/8"	9	620 x 70	620 x 70	Flanged	
ME08	MER841	Unimog	482	597	60	1/2"	13	605 x 71	605 x 71	Flanged	
ME10	MER866	Coach 0405	635	635	73	5/8"	11	637 x 103	637 x 103	Flanged	
ME11	HTR1372	Bus Heater	330	229	60	1/2"	11	233 x 66	233 x 66	Flanged	
ME12	MER832	450SL	411	597	46	1/2"	13	606 x 60	606 x 60	Flanged	
ME13	N/A	School Bus	800	635	73	5/8"	11	637 x 103	637 x 103	Flanged	
CTME01	N/A	Tabbed header conversion	810	667	57	CT	13	680 x 74	680 x 74	Flanged	
CTME02	N/A	Tabbed header conversion	660	667	38	CT	14	680 x 74	680 x 74	Flanged	
CTME41	MER941	Unimog	482	597	57	CT	14	605 x 71	605 x 71	Flanged	
CTME47	MER947 / CTME01	302 Bus	595	597	57	CT	12	595 x 104	595 x 104	Flanged	
CTME66	MER966 / CTME02	0405 Bus	632	634	76	CT	11	637 x 103	637 x 103	Flanged	
CTME107	MER9107 OEX / CTME03	Bus	800	641	57	CT	14	640 x 103	640 x 103	Flanged	
CTME01	MER021	Bus	810	667	57	CT	13	680 x 78	680 x 78	Flanged	
MG											
MG01	N/A	TD	410	333	46	5/8"	11	341 x 206	341 x 62	Flanged	
MG02	MGZ807	MGB	259	470	60	1/2"	11	468 x 70	468 x 70	Flanged	
MG03	MGZ207	MGA / MGB	259	460	60	5/8"	13	468 x 70	468 x 70	Flanged	
MG04	MGZ201 NPN	Midget	408	343	46	1/2"	13	345 x 210	345 x 60	Flanged	
MG05	MGZ804	TD (features fitting hole & rib)	410	330	46	1/2"	11	343 x 208	343 x 60	Flanged	
CTMG01	MGZ907	MGA / MGB	259	460	57	CT	13	468 x 70	467 x 70	Flanged	
MITSUBISHI											
MT01	MIT803	Forklift	360	492	60	5/8"	9	505 x 70	505 x 70	Flanged	
MT02	MIT880B	Forklift	370	495	60	1/2"	6.5	502 x 73	502 x 73	Flanged	

PART NO.	CROSS REFERENCE	DESCRIPTION	CORE HEIGHT	CORE WIDTH	CORE THICKNESS	CORE TYPE	FPI	TOP HEADER PLATE	BOTTOM HEADER PLATE	HEADER PLATE TYPE	GASKET SET
MITSUBISHI (continued)											
MT03	MIT281	Forklift	358	492	46	5/8"	13	505 x 72	505 x 72	Flanged	
MT04	MIT892	FV Truck	700	730	101	5/8"	9	725 x 148	725 x 128	Flanged	
MT05	MIT883x4	FM Truck	630	622	60	1/2"	11	628 x 80	628 x 80	Flanged	
CTMT01	N/A	Delicia	400	590	57	CT	14	600 x 61	600 x 61	Flanged	
CTMT06	MIT9107 / CTMT01	FM Truck	702	731	57	CT	15	737 x 84	737 x 84	Flanged	
CTMT15	MIT998	FK Truck	570	623	38	CT	13	625 x 80	625 x 80	Flanged	
CTMT16	MIT9141	Canter	510	479	38	CT	16	487 x 48	487 x 48	Flanged	
CTMT40	MIT940	FK Truck	570	550	57	CT	16	560 x 108	560 x 108	Flanged	
CTMT53	MIT953	Forklift	460	460	57	CT	12	495 x 76	495 x 76	Flanged	
CTMT78	MIT878 OEX	Forklift	320	488	57	INL	6.5	502 x 73	502 x 73	Flanged	
CTMT83	MIT983	FM / FK	630	620	38	CT	16	628 x 80	628 x 80	Flanged	
CTMT95	MIT995 OEX	L300	400	589	38	CT	13	595 x 46	595 x 46	Flanged	
CTMT108	MIT9108 / CTMT02	FM Truck	702	735	38	CT	15	737 x 84	737 x 84	Flanged	
CTMT111	MIT9111	Pajero	425	600	38	CT	16	605 x 66	605 x 66	Flanged	
CTMT148	MIT9148 / CTMT03	FM658 Truck	630	610	38	CT	20	615 x 70	615 x 70	Flanged	
CTMT117	MIT9117 / CTMT04	FK Truck	570	546	76	CT	12	560 x 108	560 x 108	Flanged	
CTMT86	MIT986 / CTMT05	FM515 Truck	570	625	76	CT	13	625 x 86	625 x 86	Flanged	
MT07	MIT840	FK Truck	570	556	73	5/8"	11	560 x 108	560 x 108	Flanged	
MT08	MIT494	Grader (Steel Fin)	696	689	115	INL	6.5	780 x 195	780 x 195	Bolt On	
MT09	MIT779	Grader (Steel Fin)	700	689	115	INL	6.5	780 x 195	780 x 195	Bolt On	POA
MORRIS											
CTMO17	MOR917 / CTMO01	1100	259	552	38	CT	12	565 x 59	565 x 59	Flanged	
CTMO25	MOR925 / CTMO02	Mini	271	270	38	CT	16	279 x 54	279 x 54	Flanged	
MO01	MOR217	1100	259	556	46	5/8"	9	565 x 58	565 x 58	Flanged	
MOTOR COACH AUSTRALIA											
MA01	MCA304	Coach	790	619	101	5/8"	11	680 x 180	680 x 180	Bolt On	MA01GK
MA03	MCA211	Coach	695	921	101	5/8"	11	1007 x 225	1007 x 225	Bolt On	POA
MA04	MCA302	Coach	710	686	101	1/2"	11	750 x 175	750 x 175	Bolt On	POA
MA05	MCA309	Coach	846	930	60	5/8"	13	1000 x 190	1000 x 190	Bolt On	POA
NASH											
CTNS01	NAS914 OEX	Rambler	429	615	38	CT	15	630 x 74	630 x 74	Flanged	
NEW HOLLAND											
NH01	N/A	365 HW Speed rower	765	683	101	5/8"	6.5	710 x 115	710 x 115	Flanged	
NISSAN											
NA01	NIS254	Forklift F3 Series	365	476	60	5/8"	11	490 x 85	490 x 85	Flanged	
NA02	NIS883	UD Truck	848	700	101	1/2"	11	720 x 108	720 x 108	Flanged	
NA03	NIS228	UD Truck	698	714	101	5/8"	9	734 x 108	734 x 108	Flanged	
NA04	NIS(9)8133x4	UD Truck	750	597	60	1/2"	13	612 x 64	612 x 64	Flanged	
NA05	NIS250	UD Truck	705	699	87	5/8"	11	720 x 108	720 x 108	Flanged	

Industrial Radiator Cores

PART NO.	CROSS REFERENCE	DESCRIPTION	CORE HEIGHT	CORE WIDTH	CORE THICKNESS	CORE TYPE	FPI	TOP HEADER PLATE	BOTTOM HEADER PLATE	HEADER PLATE TYPE	GASKET SET
NISSAN (continued)											
NA06	NIS3127	UD Truck	800	699	101	5/8"	9	721 x 108	721 x 108	Flanged	
NA07	NIS271 OEX	UD Truck	750	699	101	5/8"	9	720 x 108	720 x 108	Flanged	
NA08	NIS812 OEX	UD Truck	580	716	73	5/8"	11	738 x 90	738 x 90	Flanged	
CTNA01	N/A	Forklift (PTR conversion)	550	600	38	CT	12	610 x 64	610 x 64	Flanged	
CTNA02	NIS949	UD Truck	700	602	57	CT	14	610 x 64	610 x 64	Flanged	
CTNA07	NIS907 OEX	Patrol	435	511	76	CT	14	519 x 92	519 x 92	Flanged	
CTNA12	NIS912	UD CK40 Truck	580	716	57	CT	14	738 x 89	738 x 89	Flanged	
CTNA15	NIS915 OEX / CTNA01	Patrol	423	519	57	CT	13	519 x 93	519 x 94	Flanged	
CTNA30	NIS930 / CTNA02	Patrol	638	450	57	CT	12	454 x 64	454 x 64	Flanged	
CTNA47	NIS947 / CTNA03	720 Ute	550	600	57	CT	12	612 x 64	612 x 64	Flanged	
CTNA73	NIS973 / CTNA04	Patrol	740	459	38	CT	14	465 x 44	465 x 44	Flanged	
CTNA68	NIS968	Navara - Diesel	430	647	38	CT	12	653 x 44	653 x 44	Flanged	
CTNA84	NIS984 OEX / CTNA05	UD Truck	600	600	38	CT	16	612 x 64	612 x 64	Flanged	
CTNA87	NIS987 / CTNA06	Urvan	360	540	38	CT	16	545 x 62	545 x 62	Flanged	
CTNA99	NIS999 OEX / CTNA07	UD Truck	800	700	38	CT	19	712 x 66	712 x 66	Flanged	
CTNA121	NIS9121 OEX / CTNA08	Cabstar	390	532	38	CT	15	553 x 64	553 x 64	Flanged	
CTNA95	N/A / CTNA09	UD Truck	850	700	57	CT	14	712 x 64	712 x 64	Flanged	
NM											
NM01	N/A	Special build	846	784	133	INL	9	859 x 216	859 x 216	Bolt On	POA
NM02	N/A	Special build	1168	864	60	1/2"	9	940 x 180	940 x 180	Bolt On	POA
NUFFIELD											
NU01	NUF202 OEX	460 Diesel Tractor	432	413	60	5/8"	9	429 x 95	429 x 70	Flanged	
ONAN											
ON01	ONA606	Gen Set	862	841	73	5/8"	11	902 x 178	902 x 178	Bolt On	AR08GK
ON02	N/A	Gen Set	867	711	60	1/2"	11	773 x 140	773 x 140	Bolt On	POA
ON03	N/A	Gen Set	965	1054	60	1/2"	11	1118 x 180	1118 x 180	Bolt On	POA
OTTAWA											
OT01	N/A	Yard Mule	780	635	60	1/2"	11	685 x 165	685 x 165	Bolt On	POA
P&H CRANE											
PH01	N/A	165 Tonne Crane	800	787	87	1/2"	9	882 x 220	882 x 220	Bolt On	POA
PERKINS											
PK01	PER204	Static generator	431	430	60	5/8"	9	441 x 83	441 x 83	Flanged	
PK02	PER205	Static generator (brass fin)	533	492	60	5/8"	9	560 x 140	560 x 140	Bolt On	POA
PK03	N/A	Compressor	505	540	46	5/8"	13	600 x 105	600 x 105	Bolt On	POA
PK04	PER801	Static	612	584	46	5/8"	13	593 x 89	593 x 89	Flanged	
PK05	PER205x5 / SP-1222	Static	533	492	73	5/8"	9	560 x 140	560 x 140	Bolt On	POA
PK06	N/A	Genset / Stationary Pump (central)	700	651	60	5/8"	13	727 x 128	727 x 128	Bolt On	POA
PK07	PER206	Static	458	445	46	5/8"	9	490 x 105	490 x 105	Bolt On	POA
PK08	N/A	1006T Engine	700	683	60	5/8"	11	730 x 130	730 x 130	Bolt On	POA

PART NO.	CROSS REFERENCE	DESCRIPTION	CORE HEIGHT	CORE WIDTH	CORE THICKNESS	CORE TYPE	FPI	TOP HEADER PLATE	BOTTOM HEADER PLATE	HEADER PLATE TYPE	GASKET SET
PERKINS (continued)											
CTPK01	PER901	Static	610	590	57	CT	11	593 x 89	593 x 89	Flanged	
CTPK03	N/A	Lighting Tower	500	352	38	CT	14	348 x 53	348 x 53	Flanged	
CTPK04	N/A	Lighting Tower	440	352	38	CT	14	348 x 53	348 x 53	Flanged	
CTPK10	PER950	Genset / Stationary Pump (central)	560	560	57	CT	10	590 x 112	590 x 112	Flanged	
PE01	N/A	359 Cabover & Conventional	920	889	73	5/8"	13	952 x 165	952 x 165	Bolt On	POA
PE02	PTB606	359 Cabover & Conventional	952	984	101	5/8"	11	1044 x 245	1026 x 178	Bolt On	POA
PE03	PTB803	359 & Conventional	920	889	73	5/8"	11	952 x 165	952 x 165	Bolt On	POA
P J BERRIMAN											
PB01	PJB701 / MD1642	Mine Truck	483	540	152	INL	9	600 x 215	600 x 215	Bolt On	PB01GK
PB01BS	PJB701	Mine Truck (Solder Coated both faces)	483	540	152	INL	9	600 x 215	600 x 215	Bolt On	PB01GK
PB02	SBW798 NPN	Mine Truck	483	540	115	KAT	9	600 x 178	600 x 178	Bolt On	POA
PB03	PJB7010EX	7 row OEX	483	540	134	INL	9	600 x 215	600 x 215	Bolt On	PB01GK
PB03BS	PJB7010EX	7 row (Solder Coated both faces)	483	540	134	INL	9	600 x 215	600 x 215	Bolt On	PB01GK
PB04	PJB602 / SBW798	Mine Truck	483	540	115	5/8"	9	600 x 178	600 x 178	Bolt On	POA
PB05	MDF-1631	Mine Truck 3 pass	483	540	140	16S	9	600 x 215	600 x 215	Bolt On	PB01GK
PLASSER RAIL											
PL01	N/A	Rail Tamper	735	889	101	1/2"	11	888 x 140	888 x 140	Flanged	
POWERTRANS											
RB	X-Ref	Description	H	W	T	Const	fpi	Top HP	Btm HP		
PW01	MLF1752	Pit Hauler	1068	1168	72		11	1246 x 178	1246 x 178	Bolt On	POA
RFW											
RF01	RFW502	Cummins 555 / Detroit 6V	787	619	101	5/8"	9	687 x 178	687 x 178	Bolt On	POA
ROLLS ROYCE											
CTRR01	N/A	Silver Shadow	410	648	57	CT	13	664 x 79	664 x 79	Flanged	
CTRR02	ROL903	Silver Spirit / Silver Spur	410	690	57	CT	14	703 x 63	703 x 63	Flanged	
ROVER											
RV01	ROV806	Landrover (heavy duty)	441	470	73	1/2"	11	478 x 114	478 x 83	Flanged	
RV02	ROV206	Landrover	441	476	73	5/8"	11	478 x 114	478 x 83	Flanged	
RV03	ROV203	Landrover 2.25L	441	397	60	5/8"	9	405 x 114	405 x 64	Flanged	
CTRV03	ROV903	Landrover 2.25L	441	394	57	CT	13	405 x 114	405 x 64	Flanged	
RV04	ROV205	75 / P4 Sedan	476	460	46	5/8"	11	459 x 84	459 x 84	Flanged	
RV05	ROV831	Landrover V8 petrol	658	394	60	1/2"	11	417 x 65	417 x 65	Flanged	
RV09	ROV8290EX	Landrover V8 petrol	658	394	60	1/2"	11	417 x 66	417 x 66	Flanged	
CTRV10	ROV910 / CTRV01	Rover 2.6L	441	470	57	CT	13	478 x 68	478 x 68	Flanged	
CTRV11	ROV944	Discovery	692	386	38	CT	15	416 x 84	416 x 84	Flanged	
CTRV50	ROV950	Defender	418	415	57	CT	15	415 x 86	415 x 86	Flanged	
CTRV12	ROV946	Discovery	418	388	57	CT	15	415 x 86	415 x 86	Flanged	

Industrial Radiator Cores

PART NO.	CROSS REFERENCE	DESCRIPTION	CORE HEIGHT	CORE WIDTH	CORE THICK-NESS	CORE TYPE	FPI	TOP HEADER PLATE	BOTTOM HEADER PLATE	HEADER PLATE TYPE	GASKET SET
ROADTEC											
RT01	N/A	R150 Asphalt Paver (Brass fin dim tubes)	660	286	115	5/8"	11	308 x 137	308 x 137	Flanged	
SAMSUNG											
SM01	SAM309	SE 280 Excavator (Brass fin)	910	746	101	5/8"	11	760 x 130	760 x 130	Bolt On	POA
SM02	SAM707	Excavator	860	795	76	INL	9	795 x 82	795 x 82	Flanged	
SM03	N/A	Loader	960	778	101	5/8"	9	860 x 210	860 x 210	Bolt On	POA
SM04	SAM706	Loader	940	753	INL	INL	9	758 x 128	758 x 128	Flanged	
SCANIA											
SC01	SCA808	Bus	645	660	60	1/2"	13	685 x 88	685 x 88	Flanged	
SC02	SCA805	LB81 / R112	715	762	60	5/8"	11	781 x 97	781 x 97	Flanged	
SC03	SCA807	R142	713	1003	46	5/8"	13	1045 x 98	1045 x 98	Flanged	
SC04	SCA804	112 / 113 / 142 / 143	972	775	60	1/2"	11	780 x 95	780 x 95	Flanged	
SC05	SCA808x5	Bus (Heavy duty 5 row)	650	660	73	1/2"	13	685 x 88	685 x 88	Flanged	
SC06	SCA810	Cabover	970	730	60	5/8"	13	780 x 97	780 x 97	Flanged	
SC09	SCA809	LB81 / R112	718	762	60	1/2"	11	783 x 96	783 x 96	Flanged	
SCAT											
SA01	SCT801	Skidsteer	425	495	60	1/2"	9	500 x 64	500 x 64	Flanged	
CTSA01	SCT901	Skidsteer	425	497	57	CT	10	498 x 64	498 x 64	Flanged	
SDLG											
SD01	N/A	LG936 Loader	801	700	95	INL	6.5	757 x 158	757 x 158	Bolt On	POA
SPECIAL MINING VEHICLES											
SV01	SMV701	Drift Runner, Perkins engine	635	583	95	INL	11	644 x 178	644 x 178	Bolt On	SV01GK
SV01BS	N/A	Solder Coated Both Faces	635	583	95	INL	11	644 x 178	644 x 178	Bolt On	SV01GK
MFSV01	MLF1620	Drift Runner	635	592	89	OE	11	644 x 178	644 x 178	Bolt On	SV01GK
SV02	SMV702	Drift Runner - Low Profile	635	492	87	5/8"	9	559 x 178	559 x 178	Bolt On	POA
STEIGER											
ST01	STE501	Couger	790	935	115	5/8"	9	980 x 215	980 x 215	Bolt On	POA
ST02	STE503	Tiger	1243	1095	115	5/8"	9	1140 x 200	1140 x 200	Bolt On	POA
ST03	N/A	Tractor	805	778	100	5/8"	9	805 x 155	805 x 155	Flanged	
SULLAIR											
SU01	N/A	Compressor	1490	1429	73	5/8"	9	1525 x 223	1525 x 223	Bolt On	POA
SUZUKI											
CTSZ01	SUZ9130EX / CTSZ01	Swift	350	389	38	CT	13	396 x 46	396 x 46	Flanged	
TATA											
CTTA01	TAT901	Utility 2L	483	482	57	CT	16	498 x 76	498 x 76	Flanged	
TCM FORKLIFT											
TC01	TCM806	Forklift	608	597	87	1/2"	9	602 x 98	602 x 98	Flanged	
TC02	TCM801	Forklift H20	400	432	60	1/2"	9	435 x 78	435 x 78	Flanged	
TC03	TCM210	Forklift	600	647	96	INL	6.5	655 x 135	655 x 135	Flanged	
TC04	TCM806 OEX	Forklift	608	597	87	5/8"	9	608 x 98	608 x 98	Flanged	

PART NO.	CROSS REFERENCE	DESCRIPTION	CORE HEIGHT	CORE WIDTH	CORE THICKNESS	CORE TYPE	FPI	TOP HEADER PLATE	BOTTOM HEADER PLATE	HEADER PLATE TYPE	GASKET SET
TEREX											
TX01	N/A	TA40 Dump Truck	705	889	101	5/8"	9	944 x 216	944 x 216	Bolt On	POA
TOFT											
TF01	TOF717B	Harvester	904	880	115	INL	6.5	914 x 122	914 x 122	Flanged	
TF02	TOF720B	Harvester	900	885	95	INL	6.5	882 x 127	882 x 127	Flanged	
TF03	TOF718B	Harvester	904	848	115	INL	5.5	914 x 122	914 x 122	Flanged	
TF04	TOF212	Versatile	790	762	87	5/8"	9	800 x 122	800 x 122	Flanged	
TF05	TOF704B	Harvester	902	912	95	INL	6.5	914 x 110	914 x 110	Flanged	
TF06	TOF701B	Harvester	610	912	115	INL	6.5	915 x 115	915 x 115	Flanged	
TORO											
T001	N/A	7200 Series Mower	415	460	73	5/8"	9	470 x 81	470 x 81	Flanged	
TOYOTA											
TY01	TOY7205 / TOY2205	Forklift	428	413	76	INL	6.5	435 x 84	435 x 84	Flanged	
TY02	TOY7181	Forklift	498	430	76	INL	6.5	440 x 98	440 x 98	Flanged	
TY03	TOY2208	Forklift	390	500	57	5/8"	9	505 x 70	505 x 70	Flanged	
TY04	TOY895x4	Landcruiser	400	610	60	1/2"	13	615 x 61	615 x 61	Flanged	
TY05	TOY8172x4	Hilux	452	533	60	1/2"	13	635 x 64	635 x 64	Flanged	
TY06	TOY8123x5	Truck	534	597	73	1/2"	11	605 x 97	605 x 97	Flanged	
TY07	TOY7209	Forklift	450	424	76	INL	11	436 x 77	436 x 77	Flanged	
TY08	TOY7207 OEX	Forklift	530	544	76	INL	5.5	555 x 84	555 x 84	Flanged	
CTTY01	TOY901 OEX	Stout	321	498	57	CT	10	505 x 86	505 x 86	Flanged	
CTTY06	TOY9236x3	Hilux	476	528	57	CT	14	534 x 64	534 x 64	Flanged	
CTTY07	TOY9197 / CTTY01	Dyna	490	610	38	CT	14	615 x 60	615 x 60	Flanged	
CTTY08	TOY9209 / CTTY02	Forklift	450	430	57	CT	14	436 x 75	436 x 75	Flanged	
CTTY12	TOY9291	Dyna	550	590	57	CT	12	600 x 70	600 x 70	Flanged	
CTTY13	TOY9289	Coaster / Dyna	510	590	57	CT	13	598 x 73	598 x 73	Flanged	
CTTY56	TOY9356	Truck	480	600	57	CT	12	606 x 98	606 x 98	Flanged	
CTTY57	TOY9156	Landcruiser	450	530	57	CT	13	535 x 78	535 x 78	Flanged	
CTTY106	TOY9106	Dyna	400	430	57	CT	14	437 x 77	437 x 77	Flanged	
CTTY123	TOY9123	Truck	534	598	57	CT	12	605 x 96	605 x 96	Flanged	
CTTY126	TOY9126	Landcruiser	398	612	57	CT	14	617 x 77	617 x 77	Flanged	
CTTY136	TOY9136	Dyna	467	527	57	CT	14	533 x 76	533 x 76	Flanged	
CTTY150	TOY9150 / CTTY03	Tarago	550	350	38	CT	14	355 x 62	355 x 62	Flanged	
CTTY154	TOY9154 / CTTY04	Dyna Crewcab	470	526	38	CT	14	533 x 60	533 x 60	Flanged	
CTTY179	TOY9179	Forklift 4FG C25	390	482	57	CT	10	505 x 70	505 x 70	Flanged	
CTTY193	TOY9193 / CTTY05	Dyna	490	610	57	CT	13	616 x 78	616 x 78	Flanged	
CTTY202	TOY9202 / CTTY06	Forklift	500	432	57	CT	12	437 x 77	437 x 77	Flanged	
CTTY233	TOY9233	Landcruiser	500	525	57	CT	14	530 x 70	530 x 70	Flanged	
CTTY256	TOY9256 / CTTY07	Landcruiser	510	600	57	CT	14	605 x 77	605 x 77	Flanged	
CTTY292	TOY9292	Dyna	550	590	38	CT	14	600 x 70	600 x 70	Flanged	

Industrial Radiator Cores

PART NO.	CROSS REFERENCE	DESCRIPTION	CORE HEIGHT	CORE WIDTH	CORE THICKNESS	CORE TYPE	FPI	TOP HEADER PLATE	BOTTOM HEADER PLATE	HEADER PLATE TYPE	GASKET SET
TRIUMPH											
TR01	TRI819	Dolomite 1850	422	318	46	1/2"	13	318 x 60	318 x 60	Flanged	
TR02	N/A	TR2 / TR3 / TR4	430	318	73	1/2"	11	489 x 86	489 x 86	Flanged	
TR03	TRI817	TR5 / TR6	418	413	60	5/8"	11	420 x 70	420 x 70	Flanged	
TWIN CITY											
TW01	TWI208	Tractor	567	556	60	5/8"	6.5	625 x 150	625 x 150	Bolt On	POA
UNIVERSAL DRILL RIG											
UD01	N/A	Drill Rig	1068	1349	60	1/2"	9	1460 x 140	1460 x 140	Bolt On	POA
VAUXHALL											
VX01	VAU213	Velox	385	524	46	5/8"	9	533 x 51	533 x 51	Flanged	
VERSATILE TRACTOR											
VR01	VER603	Tractor	915	842	87	5/8"	9	853 x 124	853 x 124	Flanged	
VR02	N/A	Tractor	785	762	87	5/8"	9	802 x 123	802 x 123	Flanged	
VOLVO											
VL01	VOL422	Use VL10	700	673	73	1/2"	11	685 x 84	685 x 84	Flanged	
VL02	VOL860	B10 B Bus	1000	575	57	1/2"	13	580 x x 86	580 x 86	Flanged	
VL03	VOL816 / ML1114	F10 / F12 Cabover	818	800	73	1/2"	11	810 x 100	810 x 100	Flanged	
VL04	VOL849	FL10	785	800	60	1/2"	13	808 x 100	808 x 100	Flanged	
VL05	VOL448	Loader	800	800	101	1/2"	6.5	810 x 110	810 x 110	Flanged	
VL06	VOL525B	L120C Loader	947	795	152	INL	6.5	812 x 174	812 x 174	Flanged	
VL07	VOL761	Loader (Core features dummy row of tubes)	1022	940	152	INL	9	955 x 175	955 x 175	Flanged	
VL08	VOL842	F16	1000	813	60	1/2"	11	812 x 100	812 x 100	Flanged	
VL09	VOL840	NL10 / NL12	880	686	60	1/2"	13	686 x 86	686 x 86	Flanged	
VL10	VOL823 / VOL422	Bus	700	673	73	1/2"	11	686 x 86	686 x 86	Flanged	
VL11	VOL740B	Loader / AD40 (Brass fin)	800	678	76	INL	6.5	688 x 86	688 x 86	Flanged	
VL12	N/A	EC 140 Excavator	768	699	76	5/8"	13	712 x 83	712 x 83	Flanged	
VL13	N/A	Loader	730	969	115	INL	9	920 x 178	920 x 178	Bolt On	POA
VL14	VOL834 OEX	Bus	534	680	73	5/8"	13	688 x 88	688 x 88	Flanged	
VL15	VOL210	F88 / G88	795	683	76	5/8"	11	684 x 86	684 x 86	Flanged	
VL17	N/A	A30C Dump Truck	998	686	101	1/2"	6.5	708 x 110	708 x 110	Flanged	
VL18	VOL211	TD100 Stationary Engine	715	673	73	1/2"	11	690 x 190	685 x 86	Flanged	
CTVL05	VOL951	FL6 Truck	640	564	57	CT	13	565 x 88	565 x 88	Flanged	
CTVL16	VOL916	F10 / F12 Cabover	818	800	57	CT	12	810 x 100	810 x 100	Flanged	
CTVL17	VOL917	F7	700	675	57	CT	12	685 x 94	685 x 94	Flanged	
CTVL20	VOL920A / CTVL01	N10 / N12	850	680	57	CT	15	686 x 86	686 x 86	Flanged	
CTVL21	VOL934	Bus	535	680	76	CT	12	688 x 88	688 x 88	Flanged	
CTVL22	VOL922	F10 / F12 Cabover	821	785	57	CT	12	808 x 100	808 x 100	Flanged	
CTVL23	VOL945	NL12	875	678	57	CT	13	688 x 86	688 x 86	Flanged	
CTVL46	VOL946 OEX / CTVL02	FL7	748	675	57	CT	12	686 x 86	686 x 86	Flanged	
CTVL49	VOL949 / CTVL03	FL10	785	792	57	CT	13	810 x 102	810 x 102	Flanged	

PART NO.	CROSS REFERENCE	DESCRIPTION	CORE HEIGHT	CORE WIDTH	CORE THICKNESS	CORE TYPE	FPI	TOP HEADER PLATE	BOTTOM HEADER PLATE	HEADER PLATE TYPE	GASKET SET
WESTERN STAR											
WE01	WES309	4900 Series	938	984	100	5/8"	11	1064 x 169	1064 x 169	Bolt On	WE01GK
WE02	WES304 / VHF1522	Western Star	942	889	73	5/8"	13	960 x 164	960 x 164	Bolt On	WE04GK
WE03	WES322 / VHF2091	Core Typeellation 4800 Series 2007>	864	984	87	5/8"	11	1064 x 169	1064 x 169	Bolt On	WE01GK
WE04	WES820 / VHF1513	4800 Series, Caterpillar	862	889	73	1/2"	11	960 x 164	960 x 164	Bolt On	WE04GK
WE05	WES811 / VHF1522	Western Star	942	895	87	1/2"	11	960 x 164	960 x 164	Bolt On	WE04GK
WE06	WES302	Conventional	995	895	73	5/8"	13	963 x 178	963 x 167	Bolt On	WE06GK
WE07	WES502	Conventional Cummins	995	895	87	5/8"	11	963 x 178	963 x 167	Bolt On	POA
WE08	N/A (WES806)	4800 Series 2008 on	1016	991	73	1/2"	13	1064 x 169	1064 x 169	Bolt On	WE01GK
WE09	WES309 (6 row) / VHF1748	Core Typeellation 1998on	938	984	87	5/8"	11	1064 x 169	1064 x 169	Bolt On	WE09GK
WE10	WES301	Conventional Cummins	995	889	60	5/8"	11	963 x 178	963 x 167	Bolt On	WE06GK
WE11	WES803T	6900 XD	940	1105	87	1/2"	11	1187 x 169	1187 x 169	Bolt On	POA
WE12	WE08 (in 5 / 8")	4800 Series 2008 on	1016	984	73	5/8"	11	1064 x 169	1064 x 169	Bolt On	WE01GK
WHITE											
WH01	WHI417	Truck	973	749	87	1/2"	11	794 x 263	794 x 152	Bolt On	POA
WH02	WHI520	Road Boss	965	889	73	5/8"	11	962 x 178	962 x 178	Bolt On	POA
WH03	N/A	Road Boss	965	1048	87	5/8"	11	1100 x 178	1100 x 178	Bolt On	POA
WH04	WHI418	22633	802	749	46	1/2"	9	794 x 263	794 x 152	Bolt On	POA
WH05											
WILLYS											
WL01	WIL201	Jeep	330	508	46	5/8"	11	506 x 95	506 x 57	Flanged	
WL02	WIL811	CJ6 Jeep	396	622	46	1/2"	11	629 x 70	610 x 54	Flanged	
CTWL09	WIL909 / CTWL01	Jeep	403	660	38	CT	16	650 x 78	650 x 54	Flanged	
YALE											
YL01	YAL7107	Forklift	447	430	76	INL	6.5	437 x 78	437 x 78	Flanged	
YL02	YAL7110	Forklift	533	551	76	INL	6.5	555 x 78	555 x 78	Flanged	
YANMAR											
CTYN01	YAN901	Tractor	325	347	38	CT	12	356 x 66	356 x 66	Flanged	
ZETOR											
ZT01	ZET705	5 & 6 Series Tractor	400	413	76	INL	9	420 x 84	420 x 84	Flanged	

Thermo Management... Experts



BEHR HELLA SERVICE

Condensers | Compressors | Driers | Radiators | Intercoolers | Fans | Visco Clutches | Blades and more...

Your complete cooling solution.

- Complete cooling solutions for passenger and commercial vehicles
- 1,000+ Australian applications
- Covering engine cooling and air conditioning
- Global supplier to OEM's
- 100+ years experience in engine cooling
- Online catalogue

BEHR 
S E R V I C E

OE PART NO.	ASHDOWN-INGRAM PART NO.
-------------	-------------------------

ALFA ROMEO

46743393	ALF66111
46743394	ALF66081
46842843	ALF66111
51702463	ALF66081
60585534	ALF66001
60619883	ALF66061
60628578	ALF66001
60651921	ALF18121

AUDI

4A0121251M	AUD15261
4B0121251AG	AUD16621
4E0121251C	AUD19091
893121251C	AUD11281
893121251E	AUD11581
893121251G	AUD11281
893121251M	AUD11581
893121251N	AUD11581
893121251S	AUD11281
893121251T	AUD11581
8A0121251B	AUD14601
8A0121251C	AUD15161
8A0121251D	AUD14601
8D0121251BB	AUD20601
8D0121251BC	AUD16621
8D0121251C	AUD16621
8D0121251D	AUD15331
8D0121251L	AUD20601
8D0121251M	AUD16621
8D0121251N	AUD15331
8E0121251	AUD66261
8E0121251B	AUD17231
8E0121251D	AUD15341
8E0121251D	AUD17231
8E0121251L	AUD17231
8E0121251M	AUD15341
8E0121251M	AUD17231
8E012151B	AUD17231
8K0121251L	AUD45581
8K0121251R	AUD53491
AA8Z8005D	AUD45631

BEHR HELLA

8MK376704611	IVE04611
8MK376705651	SAA05651
8MK376705761	IVE05761
8MK376706741	VOL06741
8MK376707251	PEU07251
8MK376708031	MAZ08031
8MK376708601	HOL08601
8MK376709031	VOL09031
8MK376709751	MER09751

OE PART NO.	ASHDOWN-INGRAM PART NO.
-------------	-------------------------

8MK376709761	MER09761
8MK376710011	JOD10011
8MK376710021	JOD10021
8MK376710051	JOD10051
8MK376710231	MER10231
8MK376710261	PEU10261
8MK376710301	BMW10301
8MK376710311	HOL10311
8MK376710321	HOL10321
8MK376710331	HOL10331
8MK376710501	MER10501
8MK376710531	MER10531
8MK376710611	BMW10611
8MK376711091	MER11091
8MK376711101	MER11101
8MK376711151	MER11151
8MK376711171	MER11171
8MK376711181	MER11181
8MK376711191	MER11191
8MK376711231	MER11231
8MK376711251	MER11251
8MK376711281	AUD11281
8MK376711311	MER11311
8MK376711331	MER11331
8MK376711371	MER11371
8MK376711451	MER11451
8MK376711501	BMW11501
8MK376711511	MER11511
8MK376711521	MER11521
8MK376711571	BMW11571
8MK376711581	AUD11581
8MK376711681	CIT11681
8MK376712001	HOL12001
8MK376712011	HOL12011
8MK376712021	MER12021
8MK376712201	MER12201
8MK376712211	BMW12211
8MK376712231	BMW12231
8MK376712291	MER12291
8MK376712311	MER12311
8MK376712401	MER12401
8MK376712421	MER12421
8MK376712441	MER12441
8MK376712461	MER12461
8MK376712491	BMW12491
8MK376712501	BMW12501
8MK376712511	BMW12511
8MK376712524	MER12524
8MK376712531	MER12531
8MK376712551	MER12551
8MK376712571	MER12571
8MK376712591	MER12591
8MK376712601	HOL12601

OE PART NO.	ASHDOWN-INGRAM PART NO.
-------------	-------------------------

8MK376712741	MER12741
8MK376713041	MER13041
8MK376713051	MER13051
8MK376713071	BMW13071
8MK376713081	BMW13081
8MK376713091	BMW13091
8MK376713101	BMW13101
8MK376713121	BMW13121
8MK376713161	BMW13161
8MK376713191	BMW13191
8MK376713251	BMW13251
8MK376713261	BMW13261
8MK376713291	MER13291
8MK376713301	VW13301
8MK376713311	VW13311
8MK376713631	VW13631
8MK376713781	VW13781
8MK376713791	POR13791
8MK376714011	MER14011
8MK376714041	VW14041
8MK376714291	POR14291
8MK376714311	MER14311
8MK376714321	MER14321
8MK376714331	MER14331
8MK376714341	HOL14341
8MK376714361	HOL14361
8MK376714371	HOL14371
8MK376714401	PEU14401
8MK376714481	VW14481
8MK376714541	VW14541
8MK376714601	AUD14601
8MK376715161	AUD15161
8MK376715261	AUD15261
8MK376715331	AUD15331
8MK376715341	AUD15341
8MK376715351	PEU15351
8MK376715471	FOR15471
8MK376716241	BMW16241
8MK376716251	BMW16251
8MK376716271	BMW16271
8MK376716291	REN16291
8MK376716331	MER16331
8MK376716551	PEU16551
8MK376716561	CIT16561
8MK376716611	VW16611
8MK376716621	AUD16621
8MK376716651	POR16651
8MK376717191	BMW17191
8MK376717221	BMW17221
8MK376717231	AUD17231
8MK376717281	FIA17281
8MK376717291	PEU17291
8MK376717351	CIT17351

X Reference Guide

OE PART NO.	ASHDOWN-INGRAM PART NO.
BEHR HELLA (continued)	
8MK376717531	PEU17531
8MK376717551	IVE17551
8MK376717591	PEU17591
8MK376717701	VW17701
8MK376717781	REN17781
8MK376718001	BMW18001
8MK376718011	MER18011
8MK376718011	MER18011
8MK376718121	ALF18121
8MK376718321	ROV18321
8MK376718571	MER18571
8MK376718751	BMW18751
8MK376719001	AUD19001
8MK376719091	AUD19091
8MK376719131	BMW19131
8MK376719161	VW19161
8MK376719171	VW19171
8MK376719181	VW19181
8MK376719201	CIT19201
8MK376719511	CIT19511
8MK376719601	PEU19601
8MK376719611	PEU19611
8MK376719661	REN19661
8MK376719671	REN19671
8MK376719701	VW19701
8MK376719741	MER19741
8MK376719751	MER19751
8MK376720221	FOR20221
8MK376720301	FOR20301
8MK376720311	FOR20311
8MK376720381	MER20381
8MK376720401	HOL20401
8MK376720411	HOL20411
8MK376720531	SAA20531
8MK376720591	VW20591
8MK376720601	AUD20601
8MK376720641	HOL20641
8MK376720661	SAA20661
8MK376720781	SAA20781
8MK376720791	VOL20791
8MK376721021	MER21021
8MK376721031	MER21031
8MK376721101	MER21101
8MK376721111	MER21111
8MK376721141	MER21141
8MK376721151	MER21151
8MK376721171	MER21171
8MK376721201	MER21201
8MK376721211	MER21211
8MK376721231	MER21231
8MK376721381	MER21381

OE PART NO.	ASHDOWN-INGRAM PART NO.
8MK376721391	MER21391
8MK376721411	MER21411
8MK376721431	MER21431
8MK376721441	MER21441
8MK376721461	MAN21461
8MK376721491	MER21491
8MK376721511	DAF21511
8MK376721581	IVE21581
8MK376721601	IVE21601
8MK376721611	IVE21611
8MK376721621	SCA21621
8MK376721631	MER21631
8MK376721711	MAN21711
8MK376721741	IVE21741
8MK376721781	MAC21781
8MK376721791	IVE21791
8MK376722001	MER22001
8MK376722241	MAN22241
8MK376722351	MER22351
8MK376722411	MAN22411
8MK376724501	IVE24501
8MK376724561	IVE24561
8MK376724611	SCA24611
8MK376726481	MAC26481
8MK376726551	VOL26551
8MK376726701	VW26701
8MK376726761	VOL26761
8MK376729531	POR29531
8MK376729601	VOL29601
8MK376730561	MER30561
8MK376730581	POR30581
8MK376733431	HOL33431
8MK376733441	HOL33441
8MK376733451	HOL33451
8MK376733461	HOL33461
8MK376733671	POR33671
8MK376745111	FIA45111
8MK376745581	AUD45581
8MK376745631	AUD45631
8MK376745721	ROV45721
8MK376745761	BMW45761
8MK376745771	HOL45771
8MK376749501	MIN49501
8MK376749511	MIN49511
8MK376749521	MIN49521
8MK376749551	MER49551
8MK376753351	FRE53351
8MK376753361	FRE53361
8MK376753451	FRE53451
8MK376753471	FRE53471
8MK376753491	AUD53491
8MK376753551	MAC53551
8MK376753561	FRE53561

OE PART NO.	ASHDOWN-INGRAM PART NO.
8MK376754031	BMW54031
8MK376754061	BMW54061
8MK376754071	BMW54071
8MK376754081	HOL54081
8MK376754221	MIN54221
8MK376754251	MAZ54251
8MK376754591	MIN54591
8MK376754761	FOR54761
8MK376754781	FOR54781
8MK376755281	FOR55281
8MK376755381	BMW55381
8MK376756131	MER56131
8MK376758001	IVE58001
8MK376758021	MER58021
8MK376758031	MER58031
8MK376758101	VOL58101
8MK376758111	VOL58111
8MK376764031	FOR64031
8MK376764041	JAG64041
8MK376764111	FOR64111
8MK376764141	JAG64141
8MK376764311	FOR64311
8MK376765111	POR65111
8MK376765121	VW65121
8MK376765131	POR65131
8MK376765141	POR65141
8MK376766001	ALF66001
8MK376766061	ALF66061
8MK376766081	ALF66081
8MK376766111	ALF66111
8MK376766261	AUD66261
8MK376767101	PEU67101
8MK376769671	MAZ69671
8MK376769781	MER69781
8MK376771051	HOL71051
8MK376771211	HOL71211
8MK376771791	REN71791
8MK376772031	REN72031
8MK376772211	ROV72211
8MK376772401	SAA72401
8MK376773771	VW73771
8MK376774031	VW74031
8MK376774041	VW74041
8MK376774131	VOL74131
8MK376774171	VOL74171
8MK376774201	VOL74201
8MK376774231	VOL74231
8MK376774431	IVE74431
8MK376774441	MAN74441
8MK376774791	VOL74791
8MK376775001	VOL75001
8MK376781091	VW81091
8MK376781131	REN81131

OE PART NO.	ASHDOWN-INGRAM PART NO.
8MK376781431	HOL81431
8MK376781471	MAZ81471
8MK673753341	FRE53341
8ML376720391	MER20391CAC
8ML376723431	MIN23431CAC
8ML376723531	MER23531CAC
8ML376723541	VW23541CAC
8ML376724051	MER24051CAC
8ML376724071	REN24071CAC
8ML376724101	IVE24101CAC
8ML376724121	MER24121CAC
8ML376724251	IVE24251CAC
8ML376724291	MER24291CAC
8ML376724301	IVE24301CAC
8ML376724331	SCA24331CAC
8ML376724351	MAN24351CAC
8ML376724391	MER24391CAC
8ML376727531	IVE27531CAC
8ML376727601	IVE27601CAC
8ML376746061	VW46061CAC
8ML376746141	VW46141CAC
8ML376746161	VW46161CAC
8ML376746191	AUD46191CAC
8ML376746201	VW46201CAC
8ML376746331	MER46331CAC
8ML376746451	MIN46451CAC
8ML376746471	FOR46471CAC
8ML376746491	MER46491CAC
8ML376746561	ALF46561CAC
8ML376746611	NIS46611CAC
8ML376758131	IVE58131CAC
8ML376758151	MER58151CAC
8ML376758171	REN58171CAC
8ML376765101	FOR65101CAC
8ML376776741	IVE76741CAC
8ML376776761	IVE76761CAC
8ML376776771	IVE76771CAC
8ML376777071	VOL77071CAC
BMW	
1151700	BMW13261
1151848	BMW13191
1152747	BMW13161
1176620	BMW13161
1176771	BMW13161
1176889	BMW17191
1176901	BMW10611
1247376	BMW13081
1436036	BMW12511
1436061	BMW12491
1436062	BMW12501
1439101	BMW18751
1611565	BMW16251

OE PART NO.	ASHDOWN-INGRAM PART NO.
1611573	BMW16241
1702765	BMW13091
1702969	BMW12511
1709336	BMW13261
1709456	BMW13091
1709459	BMW13071
1712041	BMW17191
1712267	BMW11501
1712360	BMW13071
1712445	BMW13161
1712447	BMW13161
1712976	BMW17221
1719024	BMW17221
1719142	BMW13101
1719260	BMW13091
1719261	BMW13251
1719263	BMW13121
1719300	BMW17221
1719306	BMW13081
1719309	BMW13101
1723398	BMW11501
1723517	BMW13101
1723527	BMW13101
1723528	BMW11571
1723696	BMW13251
1723824	BMW13091
1723971	BMW13091
1728769	BMW13081
1728905	BMW13121
1728907	BMW13121
1728908	BMW13091
1737761	BMW13081
1737762	BMW13081
1737813	BMW12511
1742055	BMW12511
1742099	BMW12511
2227281	BMW12211
2241910	BMW13091
2241911	BMW13251
2241912	BMW13091
2241913	BMW13251
2242313	BMW13091
2246010	BMW10301
7519209	BMW19131
7519211	BMW19131
7521048	BMW54061
7534914	BMW45761
7559273	BMW54071
7570097	BMW55381
9071517	BMW16241
9071518	BMW16251
17507972	BMW18001
1711176889	BMW17191

OE PART NO.	ASHDOWN-INGRAM PART NO.
1711712363	BMW16251
1711723398	BMW11501
17002246010	BMW10301
17101439101	BMW18751
17102242313	BMW13091
17111151700	BMW13261
17111151848	BMW13191
17111176899	BMW10611
17111436036	BMW12511
17111436061	BMW12491
17111436062	BMW12501
17111439101	BMW18751
17111611565	BMW16251
17111611573	BMW16241
17111702765	BMW13091
17111709336	BMW13261
17111709456	BMW13091
17111709459	BMW13071
17111712006	BMW16251
17111712041	BMW17191
17111712267	BMW11501
17111712360	BMW13071
17111712365	BMW16251
17111712976	BMW17221
17111719024	BMW17221
17111719142	BMW13101
17111719260	BMW13091
17111719261	BMW13251
17111719263	BMW13121
17111719300	BMW17221
17111719309	BMW13101
17111723455	BMW16251
17111723517	BMW13101
17111723527	BMW13101
17111723528	BMW11571
17111723696	BMW13251
17111723824	BMW13091
17117534914	BMW45761
17117559273	BMW54071
17117570097	BMW55381
17119071517	BMW16241
17119071518	BMW16251
171000000000	BMW18001
CITROEN	
130100	CIT11681
133020	CIT17351
133021	CIT17351
133047	CIT19511
95206579	CIT17351
96001830	CIT11681
96011831	CIT17351
130100000	CIT19201

X Reference Guide

OE PART NO.	ASHDOWN-INGRAM PART NO.
CITROEN (continued)	
9611704480	CIT11681
1031Z6	CIT16561
1300N0	CIT19201
1301A1	CIT19201
1301A3	CIT19201
1301A6	CIT19201
1301A7	CIT19201
1301A9	CIT19201
1301C4	CIT11681
1301SG	CIT16561
1301SJ	CIT16561
1301Z8	CIT16561
1331CT	CIT19511
1331HK	CIT17351
1331QG	CIT11681

DAEWOO	
96180532	DAE0006
96181369	DAE1008
96182260	DAE0005
96182261	DAE1005
96273596	DAE1006
96322942	DAE1007
96351102	DAE1006
96351103	DAE0006
96413567	DAE0006
96536527	DAE0003
96553243	DAE0004
96553244	DAE0004
96553378	DAE1004
96553423	DAE0004
96553424	DAE0004
96817345	DAE0003

DAIHATSU	
76449	DAF21511
393435	DAF21511
1617324	DAF21511

DENSO	
16400B2010	L40CM
220700010	E86CA
222300210	L40CA
222300220	L40CM
225100870	RAD/CAPLGE
225101120	RAD/CAPSM
225101860	RAD/CAP
225104720	RAD/CAP2230
1220720110	E111CA
1220720290	E102CA
1220720690	E119CA

OE PART NO.	ASHDOWN-INGRAM PART NO.
1221001350	G1CA
4221000020	M47CA
4221000030	M48CM
4221000080	M49CA
4221000280	M10CM
4221000860	M14CA
4221002010	M13CM
4221004250	J31CA
4221007900	M10CA
4221300020	H26CM
4221303850	J40CM
4221304020	L21CA
4221304420	E53CA
4221304960	J22CM
4221305060	H7CA
4221305460	J16CA
4221305470	H29CA
4221306050	E85CA
4221306370	J28CA
4221306460	E44CA
4221307450	J32CM
4221310940	H32CM
4221310950	H32CA
4221312140	H43CA
4221313250	H20CA
4221313260	H20CM
4221313450	E51CA
4221313630	J27CA
4221313690	J42CA
4221314110	G8CM
4221314120	G8CA
4221314260	H23CM
4221314270	H23CA
4221315140	H18CA
4221315150	H18CM
4221315160	H19CA
4221315170	H19CM
4221315180	H24CA
4221315190	H24CM
4221315360	H34CM
4221315510	E29CA2
4221315520	E52CA
4221316570	L36CM
4221316760	H31CA
4221316940	J51CA
4221317380	H35CM
4221317440	H36CM
4221317510	E86CM
4221317860	E54CA
4221318100	M41CM
4221318250	E62CA
4221318660	J48CA
4221318670	J48CM

OE PART NO.	ASHDOWN-INGRAM PART NO.
4221318730	J51CM
4221319330	E83CA
4221319430	E28CA
4221319630	E84CA
4221319710	E80CM
4221319720	E80CA
4221319810	L9CM
4221319820	L9CA
4221319920	H30CA
4221319930	H10CA
4221319940	H28CA
4221321030	G15CM
4221321310	E63CM
4221321340	E68CA
4221321750	E70CA
4221321800	E94CM
4221322000	H38CA
4221322030	H47CM
4221322240	H39CM
4221322310	H46CA
4221322320	H46CM
4221322680	E78CA
4221323310	E87CA
4221323330	E87CM
4221323630	E81CA
4221323870	H42CA
4221323880	H42CM
4221324030	H35CA
4221324240	E88CA
4221324380	H45CA
4221324390	H45CM
4221325150	H39CA
4221325690	M44CA
4221325700	M45CM
4221325710	M45CA
4221325720	E89CM
4221325790	E90CA
4221325800	E90CM
4221325860	E32CA
4221325900	H44CA
4221325910	H44CM
4221326160	E91CA
4221326170	E91CM
4221326180	H40CA
4221326210	H40CM
4221326820	G16CA
4221327460	G17CA
4221327470	G18CM
4221329460	M44CM
4221331000	E104CM
4221331010	E105CA
4221333130	J57CM
4221334740	H55CM

OE PART NO.	ASHDOWN-INGRAM PART NO.
4221334740	H55CM
4221334750	H55CA
4221334980	M45CM
4221334980	M46CA
4221335060	J58CM
4221335070	J59CA
4221335080	J58CA
4221335100	E113CM
4221335110	E113CA
4221335170	E114CA
4221335610	E116CM
4221337350	H57CA
4221337360	H57CM
4221700650	L6CM
4221700690	L7CM
4221700720	E36CM
4221700970	E66CA
4221704160	E45CM
4221704320	E69CA
4221704450	E65CA
4221705610	E74CA
4221708460	E37CA
4221709210	M33CM
4221711490	E60CA
4221711840	E43CA
4221711880	E79CA
4221712580	M32CM
4221713490	E77CA
4221714460	M40CM
4221714470	M40CA
4221714780	L4CM
4221715590	M38CM
4221715900	L39CM
4221716040	E57CM
4221716060	E57CA
4221716100	E73CM
4221716950	E71CA
4221717040	E58CM
4221717200	L5CM
4221717320	J15CA
4221717700	E59CM
4221717710	E59CA
4221717880	E47CM
4221719760	E77CM
4221720520	E31CA
4221721100	M43CM
4221721670	E76CM
4221721920	K5CA
4221722150	G10CM
4221722160	G10CA
4221722630	L38CA
4221723040	E82CM
4221723840	E109CA

OE PART NO.	ASHDOWN-INGRAM PART NO.
4221724110	G21CM
4221724610	E99CA
4221728060	E95CA
4221728070	E95CM
4221728280	E93CM
4221728290	E93CA
4221728480	E96CA
4221728510	E97CM
4221729440	K9CA
4221729450	K9CM
4221730850	E103CA
4221730960	E106CM
4221730980	E107CM
4221730990	E108CA
4221739790	E97CA
4221900920	M29CM
4221901650	L13CM
4221902100	E35CA
4221905480	L15CA
4221907480	L26CM
SR0248	M42CA
SR0263B	M36CA
SR0263C	M36CM
SR0265A	R2CM
SR0265C	R4CA
SR0431244	G19CA
SR0531548	J54CA
SR1399B	R11CM
SR1399C	R11CA
SR1608	R7CA
SR1625	M34CM
SR1626	M35CA

FIAT

133017	FIA17281
1317828080	FIA17281
1342688080	FIA45111
1301N0	FIA17281
1301N1	FIA17281
1301N2	FIA17281
1301N3	FIA17281
1330S3	FIA45111

FORD

114764	FOR54781
115770	FOR54781
1036597	FOR20311
1061192	FOR20301
1091934	FOR20301
1103119	FOR64111
1103120	FOR64111
1104320	FOR64111
1113204	FOR64111

OE PART NO.	ASHDOWN-INGRAM PART NO.
1113206	FOR64111
1124902	FOR54781
1132690	FOR64111
1132691	FOR64111
1141490	FOR64311
1142808	FOR54781
1141490	FOR64311
1214785	FOR64311
1214785	FOR64311
1222562	FOR64311
1305492	FOR40080
1309414	FOR40080
1318177	FOR40080
1325831	FOR64311
1354177	FOR40080
1354177	FOR40080
1516267	FOR54761
1523440	FOR54761
1548603	FOR54761
4041554	FOR64111
4041555	FOR64111
4480903	FOR64111
4572061	FOR64111
6640240	FOR15471
6912241	FOR15471
7045714	FOR20221
7242485	FOR20221
7242486	FOR20221
AU8005A	FOR43281
C20115200	FOR64311
WLVH15200C	FOR40319
WLVP15200D	FOR40318
YC1H8005CB	FOR64111
YC1H8005CC	FOR64111
YC1H8005CD	FOR64111
YC1H8005CE	FOR64111
YC1H8005CF	FOR64111
YC1H8005DB	FOR64111
YC1H8005DC	FOR64111
YC1H8005DD	FOR64111
YC1H8005DE	FOR64111
YC1H8005DF	FOR64111
YC1H8005DG	FOR64111
1L2Z8005DC	FOR1949
1S7H8005AA	FOR54781
1S7H8005AB	FOR54781
1S7H8005AC	FOR54781
1S7H8005AD	FOR54781
2S6H8005CA	FOR64311
2S6H8005CB	FOR64311
2S6H8005CC	FOR64311
3M5H8005RG	FOR40080

X Reference Guide

OE PART NO.	ASHDOWN-INGRAM PART NO.
FORD (continued)	
3M5H8005RH	FOR40080
3M5H8005RJ	FOR40080
3M5H8005RK	FOR40080
3M5H8005TL	FOR40080
3M5H8005TL	FOR40080
4S6H8005DA	FOR64311
5M2183AL	FOR003CA
5S4Z-8005AA	FOR64031
8V518005BC	FOR54761
8V518005BD	FOR54761
8V518005BE	FOR54761
92VB8005CC	FOR15471
92VB8005CD	FOR15471
94VB8005GB	FOR20221
94VB8005GC	FOR20221
97BB8005CA	FOR20311
98AB8005ME	FOR20301
98AB8005MF	FOR20301
98AB8005PC	FOR20301

FREIGHTLINER	
A0516366004	FRE53451
BHTD5292	FRE53561
D5293	FRE53561
V0225001	FRE61591

HOLDEN	
1300119	HOL08601
1300120	HOL08601
1300149	HOL12001
1300150	HOL12011
1300158	HOL20401
1300161	HOL20641
1300181	HOL20641
1300189	HOL10311
1300196	HOL10321
1300209	HOL12601
1300214	HOL10311
1300214	HOL10321
1300236	HOL14341
1300237	HOL14361
1300239	HOL14371
1300247	HOL71211
1300257	HOL10321
1300257	HOL10311
1300265	HOL45771
1302058	HOL08601
6302002	HOL08601
9050728	HOL10311
9119482	HOL10321
9119483	HOL10331

OE PART NO.	ASHDOWN-INGRAM PART NO.
9129517	HOL12601
9192586	HOL12601
9193265	HOL10311
9201018	HOL10331
9201955	HOL14341
9201956	HOL14361
9201958	HOL14371
9202505	HOL10331
9202506	HOL10331
13145210	HOL45771
24418344	HOL71211
24445161	HOL14341
24445163	HOL14361
52464543	HOL20641
52479100	HOL20641
90410047	HOL12001
90410048	HOL12011
90499823	HOL20401
90528302	HOL20411
90570728	HOL10311
91190255	HOL08601
92087036	HOL81431
92145762	HOL81431
92191917	HOL33431
92191918	HOL33441
92191921	HOL33461
92253246	HOL24882
92234040	HOL24885
92253247	HOL24883
92253245	HOL24886
93177121	HOL10311
93277988	HOL10311
93277996	HOL10331
902191919	HOL33451

HONDA	
19010-RRF-T52	HON28010

HYUNDAI	
0K2FA15200	R33CM
25310-0W100	HYU1152
25310-25300	HYU1010
25310-26070	HYU0011
25310-29000	HYU1010
25310-29010	HYU1010
25310-29700	HYU0010
25310-38050	HYU0015

IVECO	
41214447	IVE21741
93809189	IVE17551
93809326	IVE17551
93813747	IVE24501

OE PART NO.	ASHDOWN-INGRAM PART NO.
93814567	IVE17551
93822906	IVE24501
97210218	IVE17551
98425619	IVE04611
98425628	IVE04611
98425703	IVE05761
99487905	IVE24561
500361629	IVE58001
504084141	IVE74431

JAGUAR	
4H8005AF	JAG64141
C2S1231	JAG64141
C2S3599	JAG64141

JEEP	
52079428AD	JEE31138

JOHN DEERE	
AL111000	JOD10021
AL111629	JOD10021
AL111639	JOD10021
AL115002	JOD10051
AL115004	JOD10021
AL116668	JOD10011

KIA	
25310-2F030	KIA1153
25311-3E250	KIA1203
OK52Y 15200C	KIA0003

MAN	
81061016397	MAN74441
81061016447	MAN74441
81061016458	MAN21711
81061016468	MAN21711
81061016472	MAN21711
81061016487	MAN22411
81061016493	MAN30621
81061016500	MAN22241
81061016501	MAN22241
81061016510	MAN21711
81061016518	MAN21711

MAZDA	
4L8Z-8005-JA	MAZ2436
BPM915200	MAZ08031
BPM915200A	MAZ08031
BPM915200B	MAZ08031
C20115200	FOR64311
YL8Z-8005-LB	MAZ1866
Z60215200C	MAZ40160

OE PART NO.	ASHDOWN-INGRAM PART NO.
MERCEDES BENZ	
5010601	MER22351
25010601	MER22351
629501001	MER22351
1235013801	MER10501
1245000103	MER12441
1245000203	MER12441
1245008703	MER12441
1265004003	MER13291
1265004103	MER13291
1265005103	MER13291
1295000103	MER11181
1405001003	MER11511
1405001503	MER11511
1405002003	MER12201
1405002103	MER12201
1635000404	MER18571
1685000202	MER13041
1685000302	MER13041
1685000602	MER13041
1685001202	MER13051
1685001302	MER13051
1685001602	MER13051
1685001702	MER13051
1685001902	MER13051
1685002002	MER13051
1695000003	MER21031
1695000303	MER21021
1695000403	MER30561
1695000404	MER30561
1695000504	MER30561
1695000703	MER21031
1695001803	MER21031
1695002103	MER30561
1705000402	MER21101
2015000603	MER11311
2015001203	MER12291
2015002003	MER14011
2015002103	MER12291
2015002803	MER11331
2015002903	MER11331
2015003803	MER11311
2015004003	MER11311
2015004103	MER14011
2015004203	MER14011
2015004303	MER12291
2015004403	MER11371
2015004603	MER11311
2015004803	MER12311
2015004903	MER12311
2015005103	MER14011
2015005303	MER11371

OE PART NO.	ASHDOWN-INGRAM PART NO.
2015006403	MER12531
2015006603	MER12531
2015008103	MER12291
2025002203	MER12021
2025003103	MER11191
2025003203	MER11191
2025003603	MER11191
2025003703	MER11191
2025004103	MER11231
2025004203	MER11231
2025005103	MER11251
2025005203	MER11251
2045000203	MER49551
2045000403	MER49551
2045002203	MER49551
2045002803	MER49551
2105000803	MER10231
2105002703	MER10231
2105002803	MER10231
2105002903	MER10231
2105003003	MER10231
2105007103	MER10231
2115000102	MER18011
2115000102	MER18011
2115000202	MER69781
2115000802	MER69781
2115002302	MER69781
2115003102	MER69781
2115003202	MER69781
2115003402	MER69781
2205001403	MER12591
2205002003	MER16331
2205002403	MER12591
3565010201	MER09761
3565010901	MER09761
6295011401	MER22351
6385011601	MER21381
6385011901	MER21391
6385012101	MER21411
6385012801	MER14311
6385013001	MER14321
6395010701	MER56131
6395011201	MER56131
6525013001	MER21171
6525016701	MER21171
6525016901	MER21171
6685000102	MER21111
9015002800	MER21441
9015003100	MER21201
9015003400	MER21441
9015003600	MER21631
9015003800	MER22001
9425000603	MER21211

OE PART NO.	ASHDOWN-INGRAM PART NO.
9425000903	MER21211
9425001203	MER21491
9425001503	MER21211
9425002303	MER21491
9425002803	MER21491
9425002903	MER21491
0010033V00	MER19751
A0010033V00	MER19751
A1235013801	MER10501
A1265004003	MER13291
A1265004103	MER13291
A1265005103	MER13291
A1295000103	MER11181
A1295000603	MER11451
A1295000703	MER11451
A1405001003	MER11511
A1405001503	MER11511
A1405002003	MER12201
A1405002103	MER12201
A1635000404	MER18571
A1685001202	MER13051
A1685001302	MER13051
A1685001602	MER13051
A1685001702	MER13051
A1685001902	MER13051
A1685002002	MER13051
A1695000003	MER21031
A1695000303	MER21021
A1695000403	MER30561
A1695000404	MER30561
A1695000504	MER30561
A1695000703	MER21031
A1695001803	MER21031
A1695002103	MER30561
A1705000402	MER21101
A2015000603	MER11311
A2015001203	MER12291
A2015002103	MER12291
A2015002803	MER11331
A2015002903	MER11331
A2015003803	MER11311
A2015004003	MER11311
A2015004303	MER12291
A2015004403	MER11371
A2015004603	MER11311
A2015005303	MER11371
A2015006403	MER12531
A2015006603	MER12531
A2015008103	MER12291
A2025002203	MER12021
A2025004103	MER11231
A2025004203	MER11231
A2025005103	MER11251

X Reference Guide

OE PART NO.	ASHDOWN-INGRAM PART NO.
-------------	-------------------------

MERCEDES BENZ (continued)

A2025005203	MER11251
A2045000203	MER49551
A2045000403	MER49551
A2045002203	MER49551
A2045002803	MER49551
A2105000803	MER10231
A2105002703	MER10231
A2105002803	MER10231
A2105002903	MER10231
A2105003003	MER10231
A2105007103	MER10231
A2115000102	MER18011
A2205001403	MER12591
A2205002003	MER16331
A2205002403	MER12591
A3565010201	MER09761
A3565010901	MER09761
A6385011601	MER21381
A6385012801	MER14311
A6385013001	MER14321
A6395010401	MER19741
A6395010701	MER56131
A6395011201	MER56131
A6685000102	MER21111
A9015002800	MER21441
A9015003100	MER21201
A9015003300	MER21431
A9015003400	MER21441
A9015003600	MER21631
A9015003800	MER22001

MINI

1475550	MIN49501
1475554	MIN49511
2751275	MIN54221
2751276	MIN54221
7535099	MIN54591
7570821	MIN49501
17112751275	MIN54221
17112751276	MIN54221
17117509714	MIN49501
17117535099	MIN54591
17117570821	MIN49501
171000000000	MIN49501

MITSUBISHI

1350A210	MIT1496
MR968858	MIT2233

NISSAN

21410-EB80A	NIS1507
-------------	---------

OE PART NO.	ASHDOWN-INGRAM PART NO.
-------------	-------------------------

21460-ZK30A	NIS1508
214101Y700	NIS2790

PEUGEOT

13301	PEU17531
13304	PEU17531
130938	PEU15351
133012	PEU07251
133038	PEU17531
133053	PEU17531
133064	PEU14401
133065	PEU17531
133081	PEU17591
133335	PEU07251
96141934	PEU16551
96200026	PEU07251
96270092	PEU07251
96329530	PEU17591
9614193480	PEU16551
9624765580	PEU10261
9632953080	PEU17591
9635990180	PEU14401
964000000000	PEU14401
1300H7	PEU15351
1300K5	PEU15351
1301G2	PEU16551
1301G3	PEU19601
1301G5	PEU19601
1301G8	PEU19611
1301H6	PEU19601
1301J0	PEU19601
1301J3	PEU19601
1301J5	PEU16551
1301JP	PEU16551
1301JQ	PEU19601
1301JV	PEU17291
1301K1	PEU10261
1330F8	PEU17531
1331CZ	PEU17531
1301S1	PEU17291
1301TH	PEU10261
1301TT	PEU10261
1301TX	PEU10261
1301X2	PEU17291
1330B0	PEU17531
1330H5	PEU17531
1330J4	PEU07251
1330K1	PEU67101
1330R2	PEU14401
1331LP	PEU17591
1331QY	PEU15351
1331RP	PEU19611
1331RR	PEU19601

OE PART NO.	ASHDOWN-INGRAM PART NO.
-------------	-------------------------

PORSCHE

99610603770	POR65111
99610613174	POR65131
99610613272	POR65141
99710603702	POR29531
99710613102	POR30581
99710613202	POR33671

RENAULT

7700429769	REN19661
7701499953	REN19661
7711134657	REN16291
8200008766	REN16291
8200072713	REN71791
8200115541	REN81131
8200115542	REN72031
QFC38500	REN58171CAC

SAAB

7541063	SAA05651
7549298	SAA05651
8817496	SAA05651
9333725	SAA05651

SCANIA

570473	SCA24611
1365371	SCA24611
1439504	SCA24611
1516491	SCA24611
7517001	SCA24611

SUZUKI

1770066510	SUZ1223
1770066510	SUZ1224

TOYOTA

1640036010	TOY60150
16400-00170	TOY60087
16400-0H261	TOY60276
164005B500	TOY61164
8A8Z-8005A	TOY1481

VOLKSWAGEN

068121253A	VW13631
068121253B	VW13631
068121253C	VW13631
1212531J0AD	VW13781
191121251C	VW13311
191121251F	VW13311
1J0121253H	VW13781
1J0121253J	VW13781
1J0121253N	VW13781

OE PART NO.	ASHDOWN-INGRAM PART NO.
1J0121253P	VW13781
1J0121253Q	VW13781
1J0121253ABB	VW13781
1J0121253AD	VW13781
1J0121253AH	VW13781
1J0121253AJ	VW13781
1J0121253AN	VW13781
1J0121253AP	VW13781
1J0121253AQ	VW13781
1H0121253BA	VW14041
1H0121253BE	VW14541
1H0121253BJ	VW14541
1H0121253BM	VW14041
1J0121253	VW13781
1JO.121.253AO	VW16611
1K0121251AB	VW74041
1K0121251BK	VW74041
1K0121251BL	VW65121
1K0121251DD	VW74041
1K0121251DM	VW74041
1K0121251L	VW74031
1K0121251N	VW74041
1KO.121.251AB	VW81091
1L0121253B	VW13301
2D0121253	VW19701
2D0121253D	VW19701
321121253AA	VW13301
321121253AL	VW13301
3C0121253AK	VW65121
3C0121253AL	VW74041
3C0121253AR	VW74041
3C0121253K	VW74041
3C0121253Q	VW74041
3C0121253R	VW65121
4B0121251G	VW20591
5K.0121.251J	VW26701
6Q0121253L	VW17701
6Q0121253Q	VW17701
6Q0121253R	VW17701
6Q0121253L	VW17701
701121253D	VW14481
701121253E	VW14481
701121253F	VW14481
701121253K	VW14481
7D0121253	VW73771
7H0121253F	VW19181
7H0121253G	VW19161
7H0121253H	VW19171
7H0121253J	VW19161
7H0121253K	VW19181
7H0121253M	VW19171
8D0121251AT	VW20591
8D0121251P	VW20591

OE PART NO.	ASHDOWN-INGRAM PART NO.
8D0121251Q	VW20591
VOLVO	
30665934	FOR40080
30665936	FOR40080
30683522	FOR40080
30683522A	FOR40080
446966	VOL09031
446996	VOL09031
449991	VOL09031
449992	VOL09031
449993	VOL09031
450969	VOL09031
454073	VOL09031
454074	VOL09031
1397561	VOL20791
1665249	VOL26551
1665349	VOL26551
1676636	VOL26551
3183982	VOL58111
3183983	VOL58101
3600488	VOL74231
6842768	VOL26761
8113629	VOL58101
8113630	VOL58111
8149326	VOL74791
8149362	VOL74791
8149642	VOL58101
8149683	VOL74791
8601001	VOL26761
8601354	VOL06741
8601356	VOL26761
8601433	VOL74231
8601451	VOL74201
8602065	VOL74131
8602117	VOL74171
8602414	VOL74231
8602850	VOL29601
8603634	VOL29601
8603739	VOL20791
8603823	VOL06741
8603832	VOL06741
9031105	VOL09031
9031163	VOL06741
14810301	VOL62100
20460178	VOL75001
20482259	VOL74791
20516408	VOL74791
20517350	VOL75001
20536915	VOL74791
20536920	VOL75001
20536948	VOL74791
20536961	VOL26551

OE PART NO.	ASHDOWN-INGRAM PART NO.
20555291	VOL58101
20722440	VOL74791
20722444	VOL75001
30681517	VOL29601
36000001	VOL74201
36000028	VOL29601
36000211	VOL29601
36000378	VOL29601
36002407	VOL74231
85000325	VOL74791
3M518005DA	VOL29601
3M518005EAX1	VOL29601

PART NO.	PAGE NO.
15	
15-FOR40319	189, 205, 279, 281
15-FOR43234	197
15-FOR43260	196
15-FOR43280	196
15-FOR43295	195, 206
15-HOL10321	212, 213, 236
15-HOL24200	225, 234, 379
15-HOL24300	225, 234, 379
15-HOL24500	224
15-HOL24600	224
15-HOL24700	221, 233
15-HOL24800	220, 231
15-HOL24820	210, 221, 232
15-HOL24850	209, 218, 230
15-HYU1006	247
15-HYU30060	246, 252
15-MIT42030	300, 305, 312
15-TOY60214	228, 362, 385
15-TOY60218	228, 361, 385
15-TOY60230	211, 357
15-TOY60260	357
15-TOY61165	372, 373
15-TOY61188	370

A	
AF01	413
AK01	413
AL01	413
AL02	413
AL03	413
AL04	413
AL05	413
AL06	413
ALF18121	157
ALF46561CAC	398
ALF66001	157
ALF66061	157
ALF66081	157
ALF66111	157
AR01	413
AR02	413
AR03	413
AR04	413

PART NO.	PAGE NO.
AR05	413
AR06	413
AR07	413
AR08	413
AR09	413
AR10	413
AR11	413
AT01	413
AT02	413
AT03	413
AU01	413
AU02	413
AU03	413
AUD11581	157
AUD14601	158
AUD15161	158
AUD15261	163
AUD15331	159, 163
AUD15341	160, 160, 163, 164
AUD16621	159, 160, 392
AUD17231	160, 161, 161
AUD19001	164, 164, 164, 330, 393, 393
AUD19091	163, 163
AUD20601	159, 163
AUD45581	161, 162
AUD45631	160, 160, 162, 162
AUD46191CAC	398
AUD53491	161, 162, 162, 162
AUD66261	161, 161
AV01	413
AX01	413

B	
BC01	413
BD01	414
BD02	414
BD03	414
BD04	414
BD05	414
BD06	414
BD07	414
BD08	414
BD09	414
BD10	414

PART NO.	PAGE NO.
BE01	414
BE02	414
BMW10301	170
BMW10611	169, 169
BMW11501	171, 172
BMW11571	166, 167, 168, 176
BMW12211	174, 175
BMW12231	170, 172, 173, 174
BMW12491	171, 173
BMW12501	174, 175
BMW12511	171, 171, 172, 174
BMW13071	171, 172
BMW13081	170
BMW13091	168, 171, 173, 174
BMW13101	170
BMW13121	166, 168, 174, 176
BMW13191	169, 169
BMW13251	166, 167, 176
BMW13261	167
BMW16241	166, 175, 177
BMW16251	166, 177
BMW16271	166, 177
BMW17221	167
BMW18001	170, 172, 173
BMW18751	176, 176, 176
BMW19131	169, 172, 173
BMW23091CAC	398
BMW31791CAC	398
BMW45761	170
BMW54031	165, 167
BMW54061	165, 168
BMW54071	165, 168, 175, 175
BMW55381	169, 173
BU01	414
BY01	414

C	
CA01	415
CA02	415
CA03	415
CA04	415
CA05	415
CA06	415

PART NO.	PAGE NO.
CA07	415
CA08	415
CA09	415
CA10	415
CA11	415
CA12	415
CA13	415
CA14	415
CA15	415, 417
CA16	415
CA17	415
CA18	415
CA20	415
CA21	415
CA22	415
CA23	415
CA24	416
CA25	416
CA26	416
CA27	416
CA28	416
CA29	416
CA30	416
CA31	416
CA32	416
CA33	416
CA34	416
CA35	416
CA36	416
CA37	416
CA38	416
CA39	416
CA40	416
CA41	416
CA42	416
CA43	416
CA44	416
CA45	416
CA46	416
CA47	416
CA48	416
CA49	416
CA50	416
CA51	416

PART NO.	PAGE NO.	PART NO.	PAGE NO.	PART NO.	PAGE NO.	PART NO.	PAGE NO.
CA52	416	CE01	419	CS10	414	CTHL05	426
CA53	416	CH01	418	CS11	414	CTHL10	426
CA54	416	CH02	418	CS12	414	CTHL109	426
CA55	416	CH03	418	CS13	414	CTHL11	426
CA56	416	CH04	418	CS14	414	CTHL12	426
CA57	416	CH05	418	CS15	414	CTHL13	426
CA58	417	CH06	418	CS16	414	CTHL14	426
CA59	417	CH07	418	CS17	414	CTHL157	426
CA60	417	CH08	418	CS18	414	CTHL202	426
CA61	417	CH09	418	CS19	414	CTHL26	426
CA62	417	CH10	418	CS20	415	CTHL68	426
CA63	417	CHR1111	177, 178	CS21	415	CTHL69	426
CA64	417	CHR1112	178	CS22	415	CTHL90	426
CA65	417	CHR31140	178	CS23	415	CTHL99	426
CA66	417	CHR31145	178	CS24	415	CTHN01	425
CA67	417	CHR31150	177	CS25	415	CTHN10	425
CA68	417	CIT19511	178, 328	CS26	415	CTHN19	425
CA69	417	CL01	418	CS27	415	CTHN21	425
CA70	417	CL02	418	CS28	415	CTHN23	425
CA71	417	CL03	418	CTBC03	413	CTHN24	425
CB01	417	CL04	418	CTBD26	414	CTHN26	425
CB02	417	CL05	418	CTBE03	414	CTHN27	425
CB03	417	CL06	418	CTBU02	414	CTHN28	425
CB04	417	CL07	419	CTCA01	415	CTHN29	425
CB05	417	CL08	419	CTCV02	418	CTHN30	425
CB06	418	CL09	419	CTCV03	418	CTHN32	425
CB07	418	CL10	419	CTCV24	418	CTHN35	425
CB08	418	CL11	419	CTDI44	420	CTHN37	425
CB09	418	CM01	419	CTDS01	420	CTHN40	425
CB10	418	CM02	419	CTDS02	420	CTHN57	425
CB11	418	CM03	419	CTFA06	424	CTHN76	425
CB12	418	CP01	419	CTFD10	423	CTHN92	425
CB13	418	CP02	419	CTFD123	423	CTHT01	426
CB14	418	CP03	419	CTFD142	423	CTHY01	427
CB15	418	CP04	419	CTFD149	423	CTIS01	430
CB16	418	CP05	419	CTFD210	423	CTIS02	430
CB17	418	CS01	414	CTFD212	423	CTIS03	430
CB18CAC	418	CS02	414	CTFD227	423	CTIS04	430
CB19	418	CS03	414	CTFD282	423	CTIS22	430
CB20	418	CS04	414	CTFD283	423	CTIZ01	430
CB21	418	CS05	414	CTFD296	423	CTIZ07	430
CB22CAC	418	CS06	414	CTFD49	423	CTIZ08	430
CB23	418	CS07	414	CTFD81	423	CTIZ13	430
CB24	418	CS08	414	CTHI11	425	CTIZ14	430
CB25	418	CS09	414	CTHL04	426		

PART NO.	PAGE NO.	PART NO.	PAGE NO.	PART NO.	PAGE NO.	PART NO.	PAGE NO.
C (continued)		CTME41	436	CTNT13	428	CTVL20	442
CTIZ17	430	CTME47	436	CTNT14	428	CTVL21	442
CTIZ20	430	CTME66	436	CTNT149	429	CTVL22	442
CTIZ22	430	CTMG01	436	CTNT15	428	CTVL23	442
CTIZ29	430	CTMK01	435	CTNT184	430	CTVL46	442
CTIZ31	430	CTMK32	435	CTNT37	429	CTVL49	442
CTIZ32	430	CTML01	436	CTNT41	429	CTVN01	413
CTIZ329	430	CTMO17	437	CTNT66	430	CTWL09	443
CTIZ49	430	CTMO25	437	CTPK01	439	CTYN01	443
CTIZ51	430	CTMT01	437	CTPK03	439	CU01	419
CTIZ60	430	CTMT06	437	CTPK04	439	CU02	419
CTIZ61	430	CTMT108	437	CTPK10	439	CU03	419
CTIZ65	430	CTMT111	437	CTRR01	439	CU04	419
CTIZ72	430	CTMT117	437	CTRR02	439	CU05	419
CTIZ87	430	CTMT148	437	CTRV03	439	CU06	419
CTIZ93	430	CTMT15	437	CTRV10	439	CU07	419
CTIZ98	430	CTMT16	437	CTRV11	439	CU08	419
CTJD01	431	CTMT40	437	CTRV12	439	CU09	419
CTJD02	431	CTMT53	437	CTRV50	439	CU10	419
CTJE01	431	CTMT78	437	CTSA01	440	CU11	419
CTJE02	431	CTMT83	437	CTSZ01	440	CU12	419
CTJG01	431	CTMT86	437	CTTA01	440	CU13	420
CTJG12	431	CTMT95	437	CTTY01	441	CU14	420
CTJG14	431	CTMZ42	436	CTTY06	441	CU15	420
CTJG15	431	CTMZ61	436	CTTY07	441	CU16	420
CTKI01	433	CTMZ88	436	CTTY08	441	CU17	420
CTKM13	433	CTNA01	438	CTTY106	441	CU18	420
CTKM14	433	CTNA02	438	CTTY12	441	CU19	420
CTKM19	433	CTNA07	438	CTTY123	441	CU20	420
CTKM28	433	CTNA12	438	CTTY126	441	CU21	420
CTKU01	434	CTNA121	438	CTTY13	441	CU22	420
CTKU05	434	CTNA15	438	CTTY136	441	CU23	420
CTKU06	434	CTNA30	438	CTTY150	441	CU24	420
CTKU07	434	CTNA47	438	CTTY154	441	CU25	420
CTKU08	434	CTNA68	438	CTTY179	441	CU26	420
CTKU09	434	CTNA73	438	CTTY193	441	CV01	418
CTKU19	434	CTNA84	438	CTTY202	441	CW01	419
CTKW20	433	CTNA87	438	CTTY233	441	CY01	419
CTLN01	434	CTNA95	438	CTTY256	441	CY02	419
CTLN05	434	CTNA99	438	CTTY292	441	CZ01	419
CTLY06	434	CTNS01	437	CTTY56	441	D	
CTME01	436, 436	CTNT01	428	CTTY57	441	D1CA	165, 167, 175
CTME02	436	CTNT02	428	CTVL05	442	D1CM	165, 168
CTME107	436	CTNT102	430	CTVL16	442		
		CTNT11	428	CTVL17	442		

PART NO.	PAGE NO.	PART NO.	PAGE NO.	PART NO.	PAGE NO.	PART NO.	PAGE NO.
DA01	420	DN03	420	E51CA	387	E97CA	381
DA02	420	DN04	420	E52CA	363, 385	E97CM	381
DA03	420	DN05	420	E53CA	384	E98CM	381
DA04	420	DN06	420	E54CA	385	E99CA	374
DA05	420	D001	421	E57CA	369	ED10	421
DAE0001	179	DR01	421	E57CM	369	EM01	421
DAE0002	179	DR02	421	E58CM	370	EM01BS	421
DAE0003	179, 214	DR03	421	E59CA	384, 386	EM02	421
DAE0004	180, 182, 235	DS01	420	E59CM	367, 384, 386	EM03	421
DAE0005	180	DT01	421	E63CM	358	EM04	421
DAE0006	180, 181	DW01	420	E68CA	364	EM05	421
DAE0007	181	DW02	420	E69CA	384	EM05BS	421
DAE0008	181	DW03	420	E70CA	265, 355	EM06	421
DAE1001	179	DW04	420	E71CA	265	EM07	421
DAE1002	179			E73CM	370	EM07BS	421
DAE1004	180, 182, 235	E		E74CA	387	EM08	421
DAE1005	180	E102CA	267	E76CM	369	EM09	421
DAE1006	180, 181	E103CA	374	E77CA	381	EM10	421
DAE1007	181	E104CM	368	E77CM	382	EM11	421
DAE1008	181	E105CA	367	E78CA	382, 387	EM12	421
DAE1009	179, 214	E106CM	368	E79CA	387	EM13CAC	421
DAF21511	182	E107CM	367	E80CA	266, 354	EU01	422
DAF23771CAC	399	E108CA	367	E80CM	266	F	
DAF24001CAC	399	E109CA	266	E81CA	266	F16CA	314, 315
DAI1178	184, 186	E111CA	382	E82CM	369	F17CA	314, 318
DAI1191	184	E113CA	355	E83CA	365	FA01	424
DAI1199	185	E113CM	355	E84CA	365	FA02	424
DAI1250	182, 183	E114CA	354	E85CA	355, 363	FA03	424
DAI1253	184	E116CM	266	E86CA	382	FA04	424
DAI14050	185	E118CA	359	E86CM	383	FA05	424
DAI14052	185	E118CM	359	E87CA	360	FA06	424
DAI14080	186	E119CA	374	E87CM	360	FD01	422
DAI14082	186	E120CA	267	E88CA	267	FD02	422
DI06	420	E121CA	380	E89CM	355	FD03	422
DK01	421	E126CA	267	E90CA	356	FD04	422
DK02	421	E28CA	361	E90CM	355	FD04COMP1	422
DK03	421	E29CA2	227, 360, 361, 385	E91CA	356	FD04COMP2	422
DK04	421	E31CA	357	E91CM	356	FD05	422
DM01	421	E32CA	265, 356, 386	E93CA	368	FD06	422
DM02	421	E36CM	359	E93CM	369	FD07	422
DM03	421	E37CA	358	E94CM	379	FD08	422
DM04	421	E43CA	382	E95CA	381	FD09	422
DM05	421	E44CA	267	E95CM	381	FD10	422
DN01	420	E45CM	380	E96CA	380	FD11	423
DN02	420	E47CM	387				

PART NO.	PAGE NO.
F (continued)	
FD12	423
FD13	423
FD14	423
FD16	423
FD17	423
FD20	423
FD21	423
FD22	423
FD23	423
FD24	423
FD25	423
FD26	423
FD27	423
FD28	423
FD29	423
FD30	423
FD9288CA	198
FD9340CA	197
FD9340CA2	197
FE01	422
FE02	422
FE03	422
FE04	422
FE05	422
FE06	422
FE07	422
FE08	422
FE09	422
FE10	422
FE11	422
FE12	422
FE13	422
FE14	422
FE16	422
FE17	422
FIA17281	188
FIA45111	188
FIA46021CAC	399
FN01	423
FN02	423
FN03	423
FN04	423
FN05	423

PART NO.	PAGE NO.
FN06	423
FN07	423
FN08	423
FN09	423
FN10	423
FN11	423
FN12	423
FN13	423
FN14	423
FN15	424
FN16	424
FN17	424
FN19	424
FN20	424
FOR003CA	188
FOR00610	194, 207
FOR09591	194, 207
FOR1207	198
FOR15471	207
FOR1811	204
FOR1824	192
FOR1879	199
FOR1949	192
FOR1971	192
FOR20221	207
FOR20301	200
FOR2219	208
FOR40051	202, 274
FOR40053	202, 274
FOR40055	202, 274
FOR40057	201, 274, 284
FOR40059	202, 274, 284
FOR40065	201, 272, 283
FOR40067	201, 272
FOR40080	200
FOR40100	203
FOR40120	201, 203, 272, 283, 284
FOR40200	191, 283
FOR40210	191, 282
FOR40315	189, 278, 279
FOR40316	189, 279
FOR40318	188, 204, 279, 279
FOR40319	189, 205, 279, 281
FOR43020	189, 280, 285

PART NO.	PAGE NO.
FOR43022	190, 280
FOR43232	197
FOR43234	197
FOR43258	197
FOR43260	196
FOR43280	196
FOR43281	196
FOR43283	196
FOR43290	194
FOR43292	194, 206
FOR43295	195, 206
FOR43297	194, 206
FOR43298	193
FOR43299	193
FOR43300	193
FOR46471CAC	399
FOR54761	199
FOR55281	207
FOR64031	200
FOR64111	207
FOR64311	200
FOR65101CAC	399
FR01	424
FR02	424
FR02LF	424
FRE53251	208
FRE53341	208
FRE53351	209
FRE53361	208
FRE53451	209
FRE53471	209
FRE53561	208
FRE61591	208
FT01	422
FT02	422
FT03	422
FT04	422
FT05	422
FT06	422
FT07	422
FT08	422
FT09	422
FU01	424

PART NO.	PAGE NO.
G	
G10CA	199, 269
G10CM	199, 269
G17CA	271
G18CM	271
G19CA	284
G21CM	191, 283
G23CM	283
G24CA	281
G25CA	282
G26CA	270
G26CM	270
G27CM	270
G28CA	275
G30CM	276
G8CA	198, 269, 282
G8CM	198, 269
GE01	424
GL01	424
GL02	424
GM01	424
GM02	424
GR01	424
GY01	424
H	
H10CA	237
H18CA	346
H18CM	346
H19CA	346
H19CM	346
H20CA	346
H20CM	346
H23CA	348, 352
H23CM	348, 353
H24CA	347, 352
H24CM	352, 353
H26CM	242
H28CA	244
H29CA	244
H30CA	243
H31CA	244
H32CA	352
H32CM	352

PART NO.	PAGE NO.	PART NO.	PAGE NO.	PART NO.	PAGE NO.	PART NO.	PAGE NO.
H34CM	242	HN01	425	HOL24715	222	HOL71211	234, 334
H35CA	349	HN02	425	HOL24800	219, 231	HOL81431	220
H35CM	349	HN03	425	HOL24810	220	HON1089	240
H36CM	348, 352	HN04	425	HOL24820	210, 221, 232	HON1127	243
H38CA	244, 244	HN10	425	HOL24830	221	HON1204	242
H39CA	226, 348	HN13	425	HOL24850	210, 218, 230	HON1789	242
H39CM	226, 349	HOL08601	227	HOL24860	218	HON1839	237
H40CA	240	HOL10311	212	HOL24870	210, 219, 231	HON28001	237
H40CM	240	HOL10321	212, 213, 236	HOL24880	219	HON28004	237, 237
H42CA	348	HOL10331	212, 236	HOL24882	217, 230	HON28010	238
H42CM	348	HOL1106	324	HOL24883	217	HON28012	239, 239
H43CA	243	HOL12001	215, 217	HOL24885	218, 230	HON28016	240
H44CA	241	HOL12011	215	HOL24886	218	HON28017	239
H44CM	241	HOL1260	216	HOL25040	229, 230	HON28018	239
H45CA	349	HOL12601	211	HOL25050	229, 230	HON28019	239, 241
H45CM	349	HOL14341	214, 216	HOL25060	229, 253	HON28020	239
H46CA	241	HOL14361	214, 216, 234	HOL25200	215	HON28022	239
H46CM	241	HOL14371	214	HOL25205	215	HON28030	241
H47CM	243	HOL1764	227	HOL25206	215	HON28040	242
H55CA	238	HOL1765	227	HOL25209	217	HON28042	242
H55CM	238	HOL1791	216	HOL26260	226	HON28054	243
H57CA	240	HOL1823	227, 229	HOL26270	226, 233	HON28058	243
H57CM	240	HOL1833	224	HOL2695	216, 229	HON28060	236
H58CA	236	HOL1953	227	HOL2696	216, 229	HON28065	237
H59CM	345	HOL20401	235	HOL3289C	223	HR01	425
H61CA	238	HOL20641	235	HOL3290C	224	HR02	425
H62CM	351	HOL23005	235	HOL3291C	223	HR03	425
H63CA	351	HOL23007	235	HOL3292C	223, 232	HT01	425
H64CA	236	HOL23010	213	HOL3293C	224, 233	HT02	425
H65CM	238	HOL23012	213	HOL3298C	222, 233	HT03	425
H65CMAF	238	HOL23015	213	HOL3299C	222	HT04	425
H67CA	347	HOL24100	226, 379	HOL3300C	222	HT05	425
H68CM	349	HOL24200	225, 234, 379	HOL3320C	220, 231	HT06	425
H7CA	350, 351	HOL24300	225, 233, 378	HOL3321C	220	HT07	425
HB01	424	HOL24400	226, 234	HOL3322C	221	HT08	425
HB02	424	HOL24500	224	HOL3323C	220	HT09	425
HB03	424	HOL24520	223, 232	HOL3325C	210, 219, 231	HT10	425
HG01	426	HOL24530	223	HOL3326C	210, 218, 231	HT11	425
HIN1123	209	HOL24540	225, 232	HOL3327C	219	HT12	426
HIN1244	209	HOL24550	225	HOL3328C	219	HT13	426
HL01	426	HOL24600	223	HOL33431	217	HT14	426
HL02	426	HOL24700	221, 233	HOL33451	217	HT15	426
HL03	426	HOL24705	222	HOL45771	212	HT16	426
HL04	426	HOL24710	222, 232	HOL54081	212	HT17	426

PART NO.	PAGE NO.	PART NO.	PAGE NO.	PART NO.	PAGE NO.	PART NO.	PAGE NO.
H (continued)							
HT18	426	HYU1005	247	IVE21611	256	J58CA	310
HT19	426	HYU1006	247	IVE21741	256	J58CM	309
HT20	426	HYU1008	248	IVE21791	256	J59CA	309
HU01	427	HYU1010	249	IVE24031CAC	401	JAG64041	256
HU02	427	HYU1012	250	IVE24101CAC	401	JAG64141	256
HU03	427	HYU1016	253	IVE24251CAC	401	JB01	431
HU04	427	HYU1018	246	IVE24271CAC	400	JB02	431
HY01	426	HYU1020	250	IVE24301CAC	401	JB03	431
HY02	426	HYU1034	245, 262	IVE24501	255	JB04	431
HY03	426	HYU1035	245, 248	IVE24561	255	JD01	431
HY04	426	HYU1042	248	IVE27531CAC	400	JD02	431
HY05	426	HYU1043	249	IVE27601CAC	400	JD03	431
HY06	426	HYU1152	250	IVE58001	255	JD04	431
HY07	427	HYU1205	252	IVE58131CAC	400	JD05	431
HY08	427	HYU1206	252	IVE74431	254	JD06	431
HY09	427	HYU1510	253	IVE76741CAC	400	JD07	431
HY10	427	HYU30020	247	IVE76761CAC	400	JD08	431
HY11	427	HYU30050	252	IVE76771CAC	399	JD09	431
HY12	427	HYU30060	246, 252	IZ01	430	JD10	431
HY13	427	HYU30062	246	IZ02	430	JD11	431
HY14	427	HYU30070	248, 251, 251, 261	IZ03	430	JD12	431
HY15	427	HYU30080	250	IZ04	430	JD13	431
HYU0001	251, 260			IZ05	430	JD14	431
HYU0002	251	ID01	427	IZ06	430	JD15	431
HYU0003	245	ID02	427	IZ07	430	JD16	431
HYU0005	247	ID03	427	IZ08	430	JD17	431
HYU0006	247	ID04	427	IZ09	430	JD18	431
HYU0008	248	ID05	427	J		JD21	431
HYU0010	249	ID06	427	J15CA	300, 305, 311	JD22	431
HYU0011	250	ID07	427	J16CA	304	JD23	431
HYU0013	251	ID08	427	J22CM	304	JD24	431
HYU0016	253	ID09	427	J27CA	303, 306	JD25	431
HYU0018	245	ID10	427	J31CA	311	JD26	431
HYU0019	246	IS01	430	J32CM	307	JD27	431
HYU0020	249	ISU1124	254	J33CM	307	JD28	431
HYU0021	253	ISU1236	254	J40CM	311	JD29	431
HYU0034	244, 262	ISU1237	254	J42CA	299	JD30	432
HYU0035	245, 248	ISU1239	254	J48CM	307	JD31	432
HYU0042	249	ISU1240	253	J51CA	306	JD32	432
HYU0043	249	IVE04611	255	J51CM	306	JD33	432
HYU1002	252	IVE05761	255	J54CA	177	JD34	432
HYU1003	245	IVE17551	254	J57CA	309	JD35	432
HYU1004	246	IVE21581	255	J57CM	309	JEE31120	257
		IVE21601	256	J57Q	405	JEE31125	257, 258

PART NO.	PAGE NO.
JEE31127	257
JEE31130	258
JEE31131	258
JEE31132	258
JEE31136	257
JEE31138	258
JEE31140	257
JEE31144	257, 258
JG01	431
JG02	431
JG03	431
JOD10011	259
JOD10021	259
JOD10051	259
K	
K5CA	344
K9CA	342, 344
K9CM	342, 345
KA01	432
KA02	432
KB01	433
KIA0001	259, 261, 263, 264
KIA0002	260, 263, 264
KIA0003	259
KIA0004	261
KIA0005	262
KIA0006	262
KIA0007	261
KIA0011	263
KIA0012	264
KIA0013	260
KIA1002	261, 263, 264
KIA1003	260
KIA1004	261
KIA1005	263
KIA1006	262
KIA1007	262
KIA1012	264
KIA1153	260
KIA1203	263
KIA1699	260
KM01	433
KM02	433
KM03	433

PART NO.	PAGE NO.
KM04	433
KM05	433
KM06	433
KM07	433
KM08	433
KM09	433
KM10	433
KM11	433
KM12	433
KM13	433
KM14	433
KM15	433
KM16	433
KM17	433
KM18	433
KM19	433
KM20	433
KM21	433
KM22	433
KM23	433
KM24	434
KM25	434
KM26	434
KM27	434
KT01	432
KT02	432
KU01	434
KU02	434
KU03	434
KU04	434
KU05	434
KU06	434
KU07	434
KU08	434
KW01	432
KW02	432
KW03	432
KW04	432
KW05	432
KW06	432
KW07	432
KW08	432
KW09	432
KW10	432

PART NO.	PAGE NO.
KW11	432
KW12	432
KW12LF	432
KW13LF	432
KW14	432
KW15	432
KW15LF	432
KW16	432
KW17	432
KW18	432
KW19	433
KW21LF	433
KW22	433
KW23	433
KW24	433
KW25	433
KW26	433
L	
L13CM	185
L15CA	184
L21CA	184
L36CM	186, 187
L38CA	186, 187
L39CM	183, 185
L40CA	183
L40CM	183
L4CM	182, 183, 186
L5CM	182, 183, 185
L9CM	184
LA01	434
LE01	434
LE02	434
LE03	434
LE04	434
LH01	434
LH02	434
LN01	434
LN02	434
LN03	435
LN04	435
LP01	417
LP02	417
LP03	417
LP04	417

PART NO.	PAGE NO.
LP05	417
LP06	417
LP08	417
LP09	417
LP10	417
LP11	417
LP12	417
LP13	417
LP14	417
LP15	417
LP16	417
LP19	417
LP20	417
LP22	417
LY01	434
LY02	434
LY03	434
LY04	434
LY05	434
LY06	434
M	
M10CM	205
M13CM	202, 204, 275
M14CA	203, 204, 275
M32CM	189, 280
M33CM	201, 273
M34CM	198
M35CA	198, 270
M36CA	199, 270
M36CM	199, 270
M38CM	190
M40CA	191
M40CM	191, 282
M41CM	200, 271
M42CA	204
M43CM	190, 282
M44CA	195
M44CM	195
M45CA	195, 206
M45CM	195, 206
M46CA	194
M47CA	193
M48CM	193
M49CA	193

PART NO.	PAGE NO.	PART NO.	PAGE NO.	PART NO.	PAGE NO.	PART NO.	PAGE NO.
M (continued)		MAZ40155	285	ME04	436	MER14321	296
MA01	437	MAZ40156	285	ME05	436	MER14331	293
MA03	437	MAZ40157	285	ME06	436	MER16331	295
MA04	437	MAZ40158	285	ME07	436	MER18011	295
MA05	437	MAZ40160	271	ME08	436	MER18571	291
MAC21781	268	MAZ40162	271	ME10	436	MER19741	296
MAC26481	267	MAZ40163	271	ME11	436	MER19751	337
MAC27541CAC	401	MAZ40180	286	ME12	436	MER20381	294
MAC53551	268	MAZ40200	278	ME13	436	MER20391CAC	403
MAN21461	269	MAZ40201	278	MER09751	287	MER21021	292
MAN21711	269	MAZ40220	278, 284	MER10231	294	MER21031	292
MAN22241	268	MAZ40300	285	MER10501	290	MER21101	288
MAN22411	268	MAZ40350	190, 280	MER10531	290	MER21111	287
MAN23741CAC	402	MAZ40400	190, 280	MER11091	288	MER21141	288
MAN24351CAC	402	MAZ40401	281	MER11101	289	MER21151	288
MAN30621	268	MAZ40420	191, 278	MER11151	294	MER21171	288
MAN74441	268	MAZ40430	190, 280	MER11171	291	MER21201	297
MAZ08031	272	MAZ54251	276	MER11181	288	MER21211	286
MAZ1088	282	MAZ69671	276	MER11191	293, 295	MER21231	287
MAZ1249	275	MAZ81471	273, 277	MER11231	293	MER21391	296
MAZ1719	281	MC01	427	MER11251	293	MER21411	296
MAZ1774	274	MC02	427	MER11311	289	MER21431	297
MAZ1801	273	MC03	427	MER11331	289	MER21441	297
MAZ1829	276	MC04	427	MER11371	292	MER21491	286
MAZ1830	276	MC05	427	MER11521	291	MER21631	297
MAZ1858	276	MC06	427	MER12021	293	MER22001	296
MAZ1866	192, 286	MC07	427	MER12201	290	MER22351	287
MAZ1867	192	MC08	427	MER12291	292	MER23131CAC	404
MAZ2436	286	MC09	427	MER12311	292	MER23141CAC	404
MAZ2437	192, 286	MC10	427	MER12401	294	MER23391CAC	404
MAZ40050	202, 273, 284	MC11	427	MER12421	289	MER23521CAC	405
MAZ40051	203, 204, 275	MC12	427	MER12441	289	MER23531CAC	404
MAZ40052	273	MC13	428	MER12461	289	MER23731CAC	403
MAZ40100	278	MC14	428	MER12524	290	MER23791CAC	403
MAZ40103	277	MC15	428	MER12531	292	MER24011CAC	403
MAZ40120	277	MC16	428	MER12551	336	MER24051CAC	402
MAZ40125	205, 277, 281	MC17	428	MER12571	295	MER24061CAC	402
MAZ40130	205, 277	MC18	428	MER12591	290	MER24121CAC	404
MAZ40135	187, 187, 188, 205, 277	MC23	428	MER12741	294	MER24291CAC	405
MAZ40140	273	MC24	428	MER13041	291	MER24391CAC	403
MAZ40142	200, 272, 283	MC26	428	MER13051	291	MER30561	291
MAZ40144	201, 272	ME01	436	MER13291	290	MER46331CAC	404
MAZ40151	275	ME02	436	MER14011	293	MER46491CAC	405
		ME03	436	MER14311	296	MER49551	294

PART NO.	PAGE NO.	PART NO.	PAGE NO.	PART NO.	PAGE NO.	PART NO.	PAGE NO.
MER56131	295	MIT42020	300, 305, 312	MK25	435	NIS1339	317
MER58021	287	MIT42030	300, 305, 312	MK26	435	NIS1504	316
MER58031	287	MIT42038	298	MK27	435	NIS1505	316, 318
MER58151CAC	403	MIT42039	298	MK28	435	NIS1506	316, 318
MER69781	295	MIT43010	311	MK29	435	NIS1507	316, 318
MFHT15	426	MIT43012	311	MK30	435	NIS1508	315
MFNT33	429	MIT43016	311	MN01	435	NIS1772	325
MFSV01	440	MIT43022	310	MN02	435	NIS1773	325
MG01	436	MIT44500	302, 309	MN03	435	NIS1783	317
MG02	436	MIT44501	302, 308	MN04	435	NIS1826	317
MG03	436	MIT44520	302	MO01	437	NIS1956	326
MG04	436	MIT44525	302, 309	MORRIS-1	312	NIS2044	319
MG05	436	MIT44527	302, 308	MORRIS-2	312	NIS2259	319
MIN23431CAC	405	MIT44540	301, 308	MR01	436	NIS2260	319
MIN46451CAC	405	MIT44542	301, 308	MS01	436	NIS2261	321
MIN49501	297	MIT44545	301	MS02	436	NIS2262	321
MIN49511	297	MIT45020	299, 310	MT01	436	NIS2735	320
MIN49521	298	MIT45021	299, 310	MT02	436	NIS2790	320
MIN54221	298	MIT45090	307	MT03	437	NIS2810	320
MIN54591	298	MIT45095	307	MT04	437	NIS2811	320
MIT1029	303	MK01	435	MT05	437	NIS2813	320
MIT1095	307	MK02	435	MT07	437	NIS40025	213, 323
MIT1124	308	MK03	435	MT08	437	NIS40028	324
MIT1125	301	MK04	435	MT09	437	NIS40030	323, 326
MIT1144	301	MK05	435	MZ01	436	NIS40035	188, 314, 323
MIT1208	304	MK06	435			NIS40045	315, 324, 325, 326
MIT1211	300	MK07	435	N		NIS40050	324
MIT1214	300	MK08	435	NA01	437	NIS40052	324
MIT1363	299	MK09	435	NA02	437	NIS40058	326
MIT1496	299	MK10	435	NA03	437	NIS40085	313, 314
MIT1692	310	MK11	435	NA04	437	NIS4025	322
MIT1857	306	MK12	435	NA05	437	NIS4026	322, 325
MIT2085	298	MK13	435	NA06	438	NIS4029	322
MIT211	304	MK14	435	NA07	438	NIS4030	322
MIT2233	302	MK15	435	NA08	438	NIS4039	321
MIT2702	310	MK16	435	NG01	427	NIS4040	321
MIT41013	299, 301, 304, 305, 308, 331, 331, 332	MK17	435	NG02	427	NIS4042	321
MIT41014	304, 331, 331, 332	MK18	435	NG03	427	NIS4045	320
MIT41030	303, 306	MK19	435	NH01	437	NIS4046	321
MIT41040	303, 306	MK20	435	NIS1130	325	NIS41000	323
MIT41050	303	MK21	435	NIS1182	313	NIS41001	318, 319
MIT41060	303	MK22	435	NIS1213	312, 325	NIS41004	318, 319
MIT42010	305	MK23	435	NIS1229	326	NIS41005	203, 322
		MK24	435	NIS1233	316	NIS41007	203, 322
				NIS1234	314		

PART NO.	PAGE NO.
M (continued)	
NIS41015	317, 319, 326
NIS41020	313
NIS41030	327
NIS41035	327
NIS41038	317
NIS41040	317
NIS41060	316
NIS41200	323
NIS42000	315
NIS42005	313
NIS42007	313
NIS42008	313
NIS42010	315
NIS42015	314, 315
NIS46000	187
NIS46002	187
NIS46020	323
NIS46041CAC	406, 406
NIS46150	214, 324
NIS46611CAC	406, 406
NM01	438
NM02	438
NT01	428
NT01LF	428
NT02	428
NT03	428
NT03LF	428
NT04	428
NT05	428
NT06	428
NT06LF	428
NT07	428
NT08	428
NT09	428
NT10	428
NT11	428
NT12	428
NT13	428
NT14	428
NT15	428
NT16LF	428
NT17	428
NT18	429

PART NO.	PAGE NO.
NT19	429
NT20	429
NT21	429
NT22	429
NT22LF	429
NT23LF	429
NT24	429
NT25	429
NT26	429
NT27	429
NT28	429
NT30	429
NT31	429
NT32	429
NT33	429
NT34	429
NT35	429
NT36	429
NT38	429
NT39	429
NT40	429
NT41	429
NT42	429
NT43	429
NT44	429
NT45	429
NT46	429
NT47	429
NT48	429
NT49	429
NT50	429
NT51	430
NT52	430
NT53	430
NU01	438
O	
ON01	438
ON02	438
ON03	438
OT01	438
P	
P3CA	330
P3CM	330

PART NO.	PAGE NO.
PB01	439
PB01BS	439
PB02	439
PB03	439
PB03BS	439
PB04	439
PB05	439
PE01	439
PE02	439
PE03	439
PET002-4CAC	401
PEU07251	328
PEU10261	178, 327
PEU16551	328
PEU17291	327
PEU17531	327
PEU19601	328
PEU19611	328
PEU67101	327
PH01	438
PK01	438
PK02	438
PK03	438
PK04	438
PK05	438
PK06	438
PK07	438
PK08	438
PL01	439
POR13791	329
POR14291	329
POR16651	329
POR29531	329
POR30581	330
POR33671	330
POR65111	329
POR65131	328
POR65141	329
PRO1727	332
PRO1728	330
PRO1729	331
PRO1786	332
PRO1787	332
PRO51010	331, 332

PART NO.	PAGE NO.
PW01	439
R	
R11CA	250
R33CM	259
R7CA	251
RAD/CAP	410
RAD/CAP2230	410
RAD/CAPLGE	410
RAD/CAPSM	410
RB	424, 439
REN16291	333
REN17781	333
REN19661	334, 334
REN19671	333
REN24071CAC	402
REN58171CAC	402
REN71791	333
REN72031	333
REN81131	333
RF01	439
ROV18321	265
ROV45721	264
ROV72211	334
RT01	440
RV01	439
RV02	439
RV03	439
RV04	439
RV05	439
RV09	439
S	
SA01	440
SAA05651	335
SAA20531	335
SAA20661	335
SAA20781	334
SAA72401	334
SC01	440
SC02	440
SC03	440
SC04	440
SC05	440
SC06	440

PART NO.	PAGE NO.	PART NO.	PAGE NO.	PART NO.	PAGE NO.	PART NO.	PAGE NO.
SC09	440	SUZ58003	350, 350	TOY200CM	366	TOY61160	372, 373
SCA21621	335	SUZ58004	353	TOY2217	376	TOY61161	371
SCA24041CAC	407	SUZ58020	347, 353	TOY2392	364	TOY61162	354
SCA24331CAC	406	SUZ58035	350	TOY60010	362	TOY61163	354, 371
SCA24611	335	SUZ58037	351	TOY60020	363	TOY61165	371, 373
SD01	440	SUZ58110	215, 350, 351	TOY60030	363	TOY61169	371, 373
SM01	440	SV01	440	TOY60040	363	TOY61178	369
SM02	440	SV01BS	440	TOY60051	359	TOY61180	370
SM03	440	SV02	440	TOY60063	358	TOY61182	370
SM04	440			TOY60068	364	TOY61188	370
SSM0001	337			TOY60069	364	TOY61192	368
ST01	440			TOY60070	265, 354	TOY61193	368
ST02	440			TOY60087	360	TOY61194	368
ST03	440			TOY60088	360	TOY61200	378
SU01	440			TOY60101	362	TOY61201	378
SUB1070	343			TOY60140	383	TOY61202	378
SUB1482	345			TOY60141	384	TOY61203	378
SUB1631	341			TOY60145	383	TOY61204	378
SUB1683	344			TOY60146	383	TOY61205	377
SUB1754	340, 343			TOY60147	383	TOY61206	377
SUB1755	338, 340			TOY60172	365, 379, 382, 386	TOY61207	377
SUB1756	339, 340			TOY60210	362	TOY61208	377
SUB1757	343, 345			TOY60212	362	TOY61209	354, 371
SUB1758	341, 343, 345			TOY60214	228, 361, 385	TOY61210	377
SUB1759	338, 339			TOY60216	228, 362	TOY61211	376
SUB1856	342, 344			TOY60218	228, 361, 384	TOY61214	377
SUB1862	338, 339			TOY60220	228, 361	TOY61215	376
SUB1864	338, 340, 343			TOY60226	211, 358	TOY61216	376
SUB1865	339			TOY60228	211, 358	TOY61217	375
SUB56000	337, 342			TOY60230	211, 357	TOY61220	376
SUB56001	337, 341			TOY60232	211, 357, 386	TOY61230	375
SUB56020	340			TOY60252	363	TOY61232	375
SUB56021	340			TOY60260	357	TOY61240	375
SUB56024	337, 339, 341, 342			TOY60270	265, 356	TOY61242	375
SUB56025	337, 339, 342			TOY60272	356	TOY61260	266, 375
SUB56030	338			TOY61000	367	TOY61272	380
SUB56032	338			TOY61010	366	TOY61310	359
SUB56040	341, 344			TOY61020	367	TR01	442
SUB56055	344			TOY61152	372	TR02	442
SUB56060	341, 343, 345			TOY61154	372	TR03	442
SUZ1223	347			TOY61155	372	TW01	442
SUZ1224	347			TOY61156	373, 373	TX01	441
SUZ1227	351			TOY61157	374	TY01	441
SUZ58001	350			TOY61158	372	TY02	441
SUZ58002	347, 353			TOY61159	353	TY03	441

T

TC01 440

TC02 440

TC03 440

TC04 440

TF01 441

TF02 441

TF03 441

TF04 441

TF05 441

TF06 441

TO01 441

TOY08850 376

TOY09370 359

TOY09380 360

TOY09570 380

TOY09581 380

TOY100CM 366

TOY1083 358

TOY1094 364

TOY1103 386

TOY1138 374

TOY1140 387

TOY1153 364

TOY1155 371

TOY1480 388

TOY1481 388

TOY1713 383

TOY1815 374

TOY1868 366

TOY1869 365

TOY1870 365

TOY1871 365

TOY1988 366

TOY1989 366

PART NO.	PAGE NO.
T (continued)	
TY04	441
TY05	441
TY06	441
TY07	441
TY08	441
U	
UD01	442
V	
VL01	442
VL02	442
VL03	442
VL04	442
VL05	442
VL06	442
VL07	442
VL08	442
VL09	442
VL10	442
VL11	442
VL12	442
VL13	442
VL14	442
VL15	442
VL17	442
VL18	442
VOL06741	395, 395, 397
VOL09031	394
VOL20791	395, 397
VOL24341CAC	409
VOL26551	396
VOL26761	395
VOL27551CAC	409
VOL29541CAC	409
VOL29601	395, 396
VOL58101	396
VOL58111	396
VOL62100	394
VOL74131	397
VOL74171	397
VOL74201	395
VOL74231	397

PART NO.	PAGE NO.
VOL74791	396
VOL75001	396
VOL77071CAC	409
VR01	442
VR02	442
VW13301	390
VW13311	391
VW13631	394
VW13781	159, 164, 164, 388, 390
VW14041	391
VW14481	394
VW14541	335, 336, 391, 392
VW16611	388
VW17701	393
VW19161	393
VW19171	394
VW19181	393
VW19701	392
VW20591	159, 392
VW23471CAC	406, 408
VW23511CAC	409
VW23541CAC	407, 407
VW26701	158, 336, 388, 389, 390, 392
VW29571CAC	398, 409
VW32010	388
VW46061CAC	408, 408
VW46141CAC	408
VW46151CAC	407, 407
VW46161CAC	398, 407
VW46201CAC	408, 408
VW65121	158, 336, 389, 389
VW73771	394
VW74031	158, 165, 389, 389, 390, 391
VW74041	158, 336, 390, 391, 393
VW81091	159, 336, 389, 390, 391, 392
VX01	442
W	
WE01	443
WE02	443
WE03	443
WE04	443

PART NO.	PAGE NO.
WE05	443
WE06	443
WE07	443
WE08	443
WE09	443
WE10	443
WE11	443
WE12	443
WH01	443
WH02	443
WH03	443
WH04	443
WH05	443
WL01	443
WL02	443
Y	
YL01	443
YL02	443
Z	
ZT01	443

Leading the way...



Air Conditioning Components



Our wide range of quality Air Conditioning components ensures that you can service your every customer's needs. We are continually working with the world's leading brands in Air Conditioning to deliver durable products and enable our customers to tap into the latest technologies and innovations.

Our range includes Compressors, Condensers & Fans, Receiver Driers, TX Valves, Recovery Equipment, Gas & Oil, Fittings & Switches, Heater Cores & more.

From industry leading brands
OEX | Behr-Hella | Denso | Sanden | Delphi | Red Dot | Parker

Alternators & Starter Motors



Our Rotating Electrical range caters to a wide customer base which includes anything from a small engine vehicle through to the largest of mining dump trucks.

Our range includes Starter Motors, Alternators, Repair Parts for Starter Motors & Alternators, including Brushes, Bushes, Bearings, Regulators, Rectifiers, Drives, Contacts, Solenoids, Housings and more.

From industry leading brands
OEX | Bosch | Delco Remy | Denso | Leece Neville | Prestolite

Automotive Electrical Accessories



There are thousands of parts under the Auto Electrical Accessories umbrella that range from the smallest of connectors and fuses to the largest of heavy duty batteries. This extensive range caters to many industries whether it is construction, mining, agricultural or industrial.

Our range includes LED Lighting, HID lighting, work lights & emergency lighting, globes, switches, fuses, relays, flashers & circuit breakers, cable, cable accessories & connectors, batteries, battery chargers, battery accessories, reducers & inverters, warning devices, cameras, turbo timers, gauges & audio.

From industry leading brands
OEX | CTEK | Ecco | Hella | Lightforce | Narva | Phillips | Redarc

Radiators & Thermal Control



We offer specialised solutions to the radiator industry and supply a wide range of Automotive and Industrial radiator components.

Our range includes Radiators, radiator cores, top tanks, bottom tanks, & custom built NPN.

From industry leading brands
OEX | Behr-Hella | Denso | Calsonic | Redback Radiators

Radiator Catalogue

**ashdown
ingram**



Order from Australasia's largest aftermarket distributor of automotive electrical and thermal control parts all day, every day.

www.quantumpro.com.au
www.quantumpro.co.nz

POWER THROUGH INFORMATION
QUANTUM PRO

AUSTRALIA

Visit our website: www.ashdown-ingram.com.au

QUEENSLAND

Acacia Ridge	07 3276 0777
Archerfield	07 3277 8633
Ashmore	07 5528 1266
Burleigh Heads	07 5522 1377
Cairns	07 4031 3816
Emerald	07 4987 4388
Gladstone	07 4972 1677
Mackay	07 4952 3172
Mt Isa	07 4743 1633
Rockhampton	07 4921 3799
Springwood	07 3208 4244
Sunshine Coast	07 5493 9022
Support Office	07 3358 9400
Toowoomba	07 4632 9384
Townsville	07 4728 6222
Virginia	07 3633 0309

VICTORIA

Bendigo	03 5443 1900
Geelong	03 5224 2266
Sandown	03 9548 2266
Sunshine West	03 9364 7466
Thomastown	03 9462 1044
Tullamarine	03 8336 6444

SOUTH AUSTRALIA

Regency Park	08 8347 1637
Thebarton	08 8257 2345

WESTERN AUSTRALIA

Bunbury	08 9725 6734
Geraldton	08 9921 1338
Kalgoorlie	08 9021 5211
Karratha	08 9183 8117
Kewdale	08 9376 2544
Osborne Park	08 9444 8644

TASMANIA

Hobart	03 6228 0200
Launceston	03 6344 7042

NORTHERN TERRITORY

Darwin	08 8984 4222
--------	--------------

NSW & ACT

Albury	02 6041 4443
Alexandria	02 9516 3022
Canberra	02 6280 6154
Coffs Harbour	02 6652 2932
Dubbo	02 6885 2766
Newcastle	02 4961 3988
Lidcombe	02 9648 1900
Tamworth	02 6765 3199
Wagga Wagga	02 6925 5266
Wetherill Park	02 9616 0100
Wollongong	02 4271 2611

NEW ZEALAND

Visit our website: www.ashdown-ingram.co.nz

Auckland	0800 445 889	Hamilton	0800 445 889
Christchurch	0800 445 889		

Part No. CATRADIAT12

